

AsahiKASEI
ASAHI KASEI MICRODEVICES

AK1541

20 to 600MHz Delta-Sigma Fractional-N Frequency Synthesizer

1. Overview

The AK1541 is a Delta-Sigma Fractional-N PLL (Phase Locked Loop) frequency synthesizer with a frequency switching function, covering a wide range of frequencies from 20MHz to 600MHz. This product consists of an 18-bit Delta-Sigma modulator, a low-noise phase frequency comparator, a highly accurate charge pump, a reference divider and a dual-module prescaler (P/P+1).

An excellent PLL can be achieved by combining this synthesizer with the external loop filter and VCO (Voltage Controlled Oscillator). The access to the registers is controlled via a three-lines serial interface. The operating supply voltage is from 2.7V to 5.5V; and the charge pump and serial interface can be driven by individual supply voltages.

2. Features

- Delta-Sigma Fractional-N frequency synthesizer providing shorter lockup time, lower phase noise and low spurious performance
- Operating frequency: 20 to 600MHz
- On-chip charge pump for fast lockup
- Programmable charge pump current:
 - In a normal operating scheme, the charge pump current can be set in 16 steps, in the range from 10.6uA to 168.9uA.
 - In a fast lockup scheme, the charge pump current can be set in 8 steps, in the range from 0.84mA to 2.32mA.
- Supply Voltage: 2.7 to 5.5 V (PVDD and CPVDD pins)
- Separate power supply for the charge pump: PVDD to 5.5V (CPVDD pin)
- On-chip power-saving features
- On-chip PLL lock detect feature: Direct output to the PFD (Phase Frequency Detector) or digital filtering output can be selected.
- Very low consumption current: 3.4mA typ. (excluding a charge pump current)
- Package: 24pin QFN (0.5mm pitch, 4mm × 4mm × 0.75mm)
- Operating temperature: -40C° to 85C°

Table of Contents

1.	Overview	1
2.	Features	1
3.	Block Diagram	3
4.	Pin Functional Description	4
5.	Absolute Maximum Ratings	6
6.	Recommended Operating Range	6
7.	Electrical Characteristics	7
8.	Block Functional Descriptions	11
9.	Register Map	19
10.	Register Functional Description	20
11.	IC Interface Schematic	26
12.	Recommended Connection Schematic for Off-Chip Components	28
13.	Power-up Sequence	30
14.	Typical Evaluation Board Schematic	31
15.	Block Diagram by Power Supply	32
16.	Outer Dimensions	33
17.	Marking	34

In this specification (draft version), the following notations are used for specific signal and register names:

[Name]: Pin name

<Name>: Register group name (Address name)

{Name}: Register bit name

3. Block Diagram

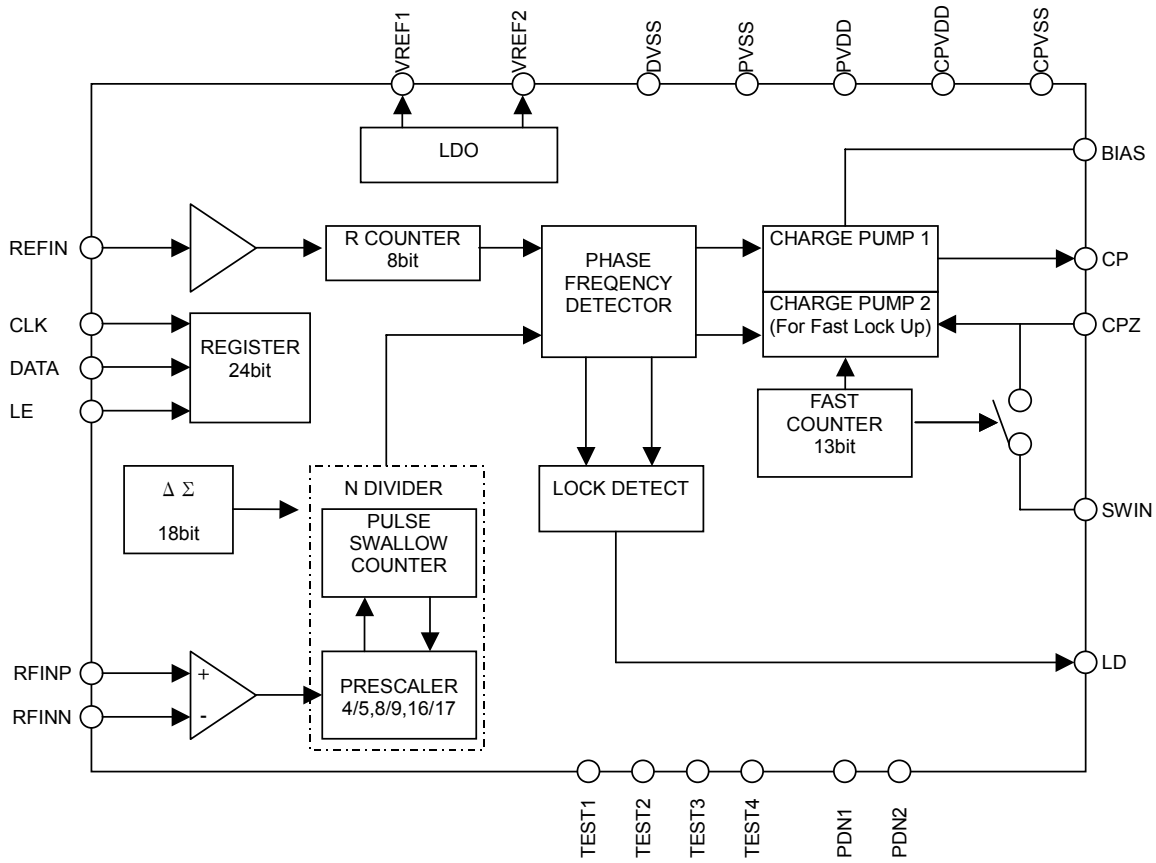

Fig. 1 Block Diagram

4. Pin Functional Description

Table 1 Pin Function

No.	Name	I/O	Pin Functions	Power down	Remarks
1	CPVDD	P	Power supply for charge pump		
2	TEST4	DI	Test pin 4		Internal pull-down, Schmidt trigger input
3	TEST1	DI	Test pin 1		Internal pull-down, Schmidt trigger input
4	LE	DI	Load enable		Schmidt trigger input
5	DATA	DI	Serial data input		Schmidt trigger input
6	CLK	DI	Serial clock		Schmidt trigger input
7	LD	DO	Lock detect	"Low"	
8	PDN2	DI	Power down pin for PLL		Schmidt trigger input
9	PDN1	DI	Power down signal for LDO		Schmidt trigger input
10	REFIN	AI	Reference input		
11	TEST2	DI	Test pin 2		Internal pull-down, Schmidt trigger input
12	TEST3	DI	Test pin 3		Internal pull-down, Schmidt trigger input
13	VREF1	AIO	Connect to LDO reference voltage capacitor	"Low"	
14	DVSS	G	Digital ground pin		
15	VREF2	AIO	Connect to LDO reference voltage capacitor	"Low"	
16	RFINN	AI	Prescaler input		
17	RFINP	AI	Prescaler input		
18	PVDD	P	Power supply for peripherals		
19	BIAS	AIO	Resistance pin for setting charge pump output current		
20	PVSS	G	Ground pin for peripherals		
21	CP	AO	Charge pump output	"Hi-Z"	
22	CPZ	AIO	Connect to the loop filter capacitor		Notes 1) & 2)
23	SWIN	AI	Connect to resistance pin for fast lockup		Notes 1) & 2)
24	CPVSS	G	Ground pin for charge pump		

Note 1) For detailed functional descriptions, see the section "Charge Pump and Loop Filter" in "8. Block Functional Description" below.

Note 2) The input voltage from the [CPZ] pin is used in the internal circuit. The [CPZ] pin must not be open even when the fast lockup feature is unused. For the output destination from the [CPZ] pin, see "P.12 Fig.5 Loop

Filter Schematic". The [SWIN] pin could be open even when the first lockup feature is not used.

Note 3) Power down refers to the state where [PDN1]=[PDN2]="Low" after power-on.

AI: Analog input pin	AO: Analog output pin	AIO: Analog I/O pin	DI: Digital input pin
DO: Digital output pin	P: Power supply pin	G: Ground pin	

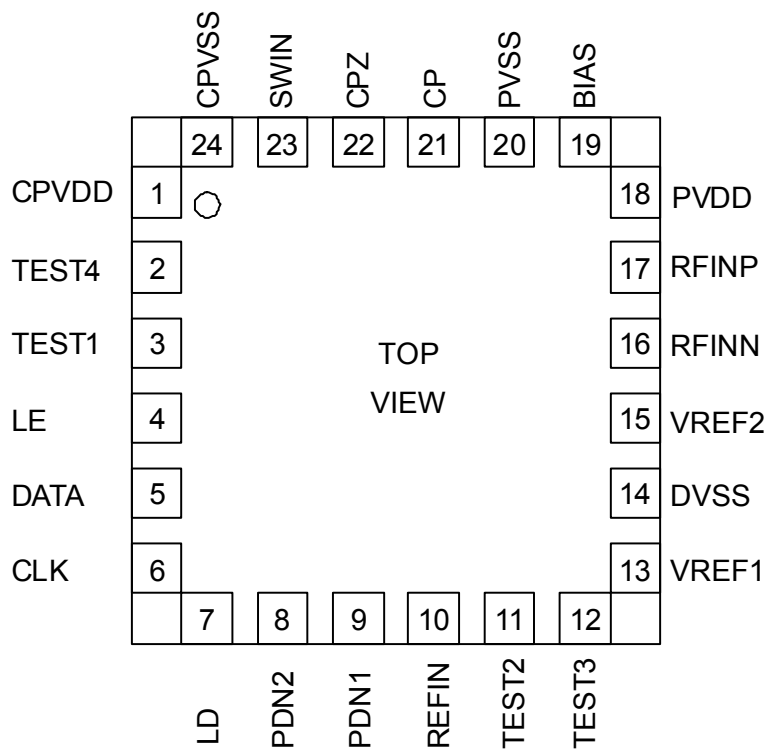

Fig. 2 Package Pin Layout

5. Absolute Maximum Ratings

Table 2 Absolute Maximum Ratings

Parameter	Symbol	Min.	Max.	Unit	Remarks
Supply Voltage	VDD1	-0.3	6.5	V	Note 1) Applied to the [PVDD] pin
	VDD2	-0.3	6.5	V	Note 1) Applied to the [CPVDD] pin
Ground Level	VSS1	0	0	V	Voltage ground level applied to the [PVSS] pin
	VSS2	0	0	V	Voltage ground level applied to the [CPVSS] pin
	VSS3	0	0	V	Voltage ground level applied to the [DVSS] pin
Analog Input Voltage	VAIN1	VSS1-0.3	VDD1+0.3	V	Notes 1) & 2)
	VAIN2	VSS2-0.3	VDD2+0.3	V	Notes 1) & 3)
Digital Input Voltage	VDIN	VSS3-0.3	VDD1+0.3	V	Notes 1) & 4)
Input Current	IIN	-10	10	mA	
Storage Temperature	Tstg	-55	125	°C	

Note 1) 0V reference for all voltages.

Note 2) Applied to the [REFIN], [RFINN] and [RFINP] pins.

Note 3) Applied to the [CPZ] and [SWIN] pins.

Note 4) Applied to the [CLK], [DATA], [LE], [PDN1], [PDN2], [TEST1], [TEST2], [TEST3] and [TEST4] pins.

Exceeding these maximum ratings may result in damage to the AK1541. Normal operation is not guaranteed at these extremes.

6. Recommended Operating Range

Table 3 Recommended Operating Range

Parameter	Symbol	Min.	Typ.	Max.	Unit	Remarks
Operating Temperature	Ta	-40		85	°C	
Supply Voltage	VDD1	2.7	3.3	5.5	V	Applied to the [PVDD] pin
	VDD2	VDD1	5.0	5.5	V	Applied to the [CPVDD] pin

Note 1) VDD1 and VDD2 can be driven individually within the recommended operating range.

The specifications are applicable within the recommended operating range (supply voltage/operating temperature).

7. Electrical Characteristics

1. Digital DC Characteristics

Table 4 Digital DC Characteristics

Parameter	Symbol	Conditions	Min.	Typ.	Max.	Unit	Remarks
High level input voltage	Vih		0.8×VDD1			V	Note 1)
Low level input voltage	Vil				0.2×VDD1	V	Note 1)
High level input current 1	Iih1	Vih = VDD1=5.5V	-1		1	μA	Note 2)
High level input current 2	Iih2	Vih = VDD1=5.5V	27	55	110	μA	Note 3)
Low level input current	Iil	Vil = 0V, VDD1=5.5V	-1		1	μA	Note 1)
High level output voltage	Voh	Ioh = -500μA	VDD1-0.4			V	Note 4)
Low level output voltage	Vol	Iol = 500μA			0.4	V	Note 4)

Note 1) Applied to the [CLK], [DATA], [LE], [PDN1], [PDN2], [TEST1], [TEST2], [TEST3] and [TEST4] pins.

Note 2) Applied to the [CLK], [DATA], [LE], [PDN1] and [PDN2] pins.

Note 3) Applied to the [TEST1], [TEST2], [TEST3] and [TEST4] pins.

Note 4) Applied to the [LD] pin.

2. Serial Interface Timing

<Write-In Timing>

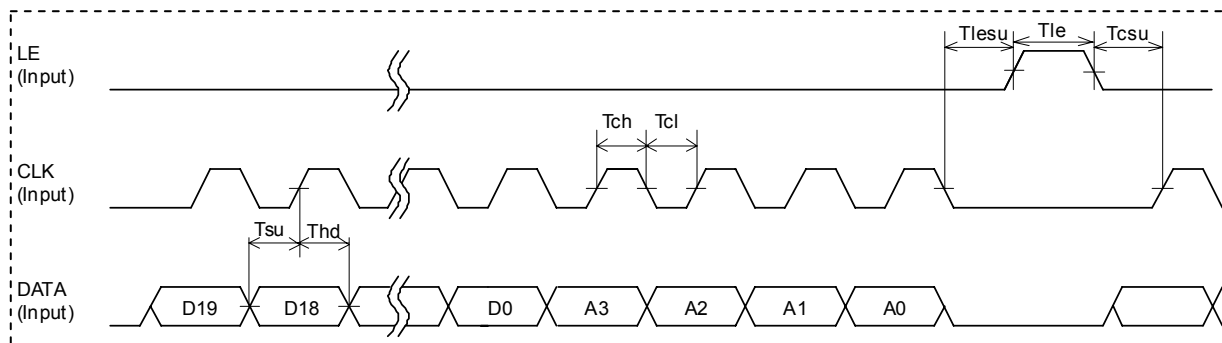

Fig. 3 Serial Interface Timing

Table 5 Serial Interface Timing

Parameter	Symbol	Min.	Typ.	Max.	Unit	Remarks
Clock L level hold time	Tchl	40			ns	
Clock H level hold time	Tchu	40			ns	
Clock setup time	Tcsu	20			ns	
Data setup time	Ttsu	20			ns	
Data hold time	Tthd	20			ns	
LE Setup Time	Tlesu	20			ns	
LE Pulse Width	Tle	40			ns	

Note 1) LE pin has to be set "Low" after register data setting completed. If LE pin keeps "High" with CLK operation, the register may not be guaranteed proper setting.

Note 2) While LE pin is setting "Low", 24 iteration clocks have to be set with CLK pin. If 25 or larger clocks are set, the last 24 clocks synchronized data are valid.

3. Analog Circuit Characteristics

The resistance of 27kΩ is connected to the [BIAS] pin, VDD1=2.7V to 5.5V, VDD2=VDD1 to 5.5V, -40°C ≤ Ta ≤ 85°C

Parameter	Min.	Typ.	Max.	Unit	Remarks
RF Characteristics					
Input Sensitivity	-15		+5	dBm	Input frequency ≥ 100MHz
	-5		+5	dBm	20MH ≤ Input frequency < 100MHz
Input Frequency	20		250	MHz	Prescaler 4/5
	20		600	MHz	Prescaler 8/9,16/17
REFIN Characteristics					
Input Sensitivity	0.4		2	Vpp	
Input Frequency	5		40	MHz	
Maximum Allowable Prescaler Output Frequency			75	MHz	
Phase Detector					
Phase Detector Frequency			3	MHz	
Charge Pump					
Charge Pump 1 Maximum Value		168.9		μA	
Charge Pump 1 Minimum Value		10.6		μA	
Charge Pump 2 Maximum Value		2.32		mA	
Charge Pump 2 Minimum Value		0.84		mA	
Icp TRI-STATE Leak Current		1		nA	0.5 ≤ Vcpo ≤ VDD2-0.5
Mismatch between Source and Sink Currents (Note 1)			10	%	Vcpo = VDD2/2, Ta = 25°C
Icp vs. Vcpo (Note 2)			15	%	0.5 ≤ Vcpo ≤ VDD2-0.5, Ta = 25°C
Others					
VREF1,2 Rise Time			50	μs	
Current Consumption					
IDD1			10	μA	[PDN1]="Low", [PDN2]="Low"
IDD2		3.4	5	mA	Note 3)
IDD3		1.2		mA	Note 4)

Note 1) Mismatch between Source and Sink Currents: $\frac{(|I_{sink}| - |I_{source}|)}{(|I_{sink}| + |I_{source}|)/2} \times 100$ [%]

Note 2) See "Fig. 4 Charge Pump Characteristics - Voltage vs. Current": Icp vs. Vcpo:

$$\frac{\{1/2 \times (|I1| - |I2|)\}}{\{1/2 \times (|I1| + |I2|)\}} \times 100$$
 [%]

Note 3) [PDN1]="High", [PDN2]="High" IDD for [PVDD]

Note 4) [PDN1]="High", [PDN2]="High" IDD for [CPVDD]

IDD does not include the operation current in fast lockup mode.

Note 5) [PDN1]="High", [PDN2]="High", the total current consumption = IDD2 + IDD3 + charge pump setting

Note 6) In the shipment test, the exposed pad on the center of the back of the package is connected to ground.

Resistance Connected to the BIAS Pin for Setting Charge Pump Output Current

Parameter	Min.	Typ.	Max.	Unit	Remarks
BIAS resistance	22	27	33	k Ω	

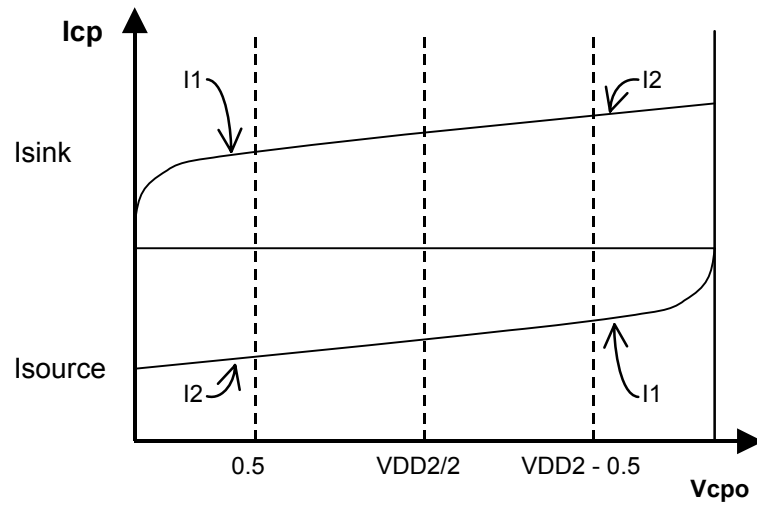
Fig. 4 Charge Pump Characteristics - Voltage vs. Current

8. Block Functional Descriptions

1. Frequency Setup

The AK1541 is a Fractional-N type synthesizer that takes 2^{18} as the denominator, which calculates the integer and numerator to be set using the following formulas:

$$\begin{aligned} \text{Frequency setting} &= \text{Ref Frequency} \times (\text{Integer} + \text{Numerator} / 2^{18}) \\ \text{Integer} &= \text{ROUND} (\text{Target Frequency} / F_{\text{PFD}}) \\ \text{Numerator} &= \text{ROUND} \{(\text{Target Frequency} - \text{Integer} \times F_{\text{PFD}}) / (F_{\text{PFD}} / 2^{18})\} \end{aligned}$$

Note) ROUND: Rounded off to the nearest value

F_{PFD} : Phase Frequency Detector comparative Frequency([REFIN] pin input frequency/R divider ratio)

● Calculation examples

Example 1) The numerator is positive when the target frequency is 465.0375MHz and the Phase Frequency Detector comparative Frequency is 1MHz.

$$\text{Integer} = 465.0375\text{MHz} / 1\text{MHz} = 465.0375$$

It is rounded off to 465 (decimal) = 1d1 (hexadecimal) = 1 1101 0001 (binary)

$$\text{Numerator} = (465.0375\text{MHz} - 465 \times 1\text{MHz}) / (1\text{MHz} / 2^{18}) = 9830.4$$

It is rounded off to 9830 (decimal) = 2666 (hexadecimal) = 10 0110 0110 0110 (binary)

$$\text{Frequency setting} = 1\text{MHz} \times (465 + 9830 / 2^{18}) = 465.0374985\text{MHz}$$

(In this case the error between the calculated frequency and the target frequency is 1.5Hz.)

Example 2) The numerator is negative when the target frequency is 468.550MHz and the Phase Frequency Detector comparative Frequency is 1MHz.

$$\text{Integer} = 468.550\text{MHz} / 1\text{MHz} = 468.550$$

It is rounded off to 469 (decimal) = 1d5 (hexadecimal) = 1 1101 0101 (binary)

$$\text{Numerator} = (468.550\text{MHz} - 469 \times 1\text{MHz}) / (1\text{MHz} / 2^{18}) = -117964.8$$

It is rounded off to -117965 (decimal), which is deduced from 2^{18} to be converted into binary for 2's complementary expression.

$$2^{18} - 117965 \text{ (decimal)} = 144179 \text{ (decimal)} = 23333 \text{ (hexadecimal)} = 10 0011 0011 0011 0011 \text{ (binary)}$$

$$\text{Frequency setting} = 1\text{MHz} \times (469 + (-117965/2^{18})) = 468.5499992\text{MHz}$$

(In this case the error between the calculated frequency and the target frequency is 0.8Hz.)

● Calculation of 2's complement representation

1) Positive number: Binary expression (Unmanipulated) exp. 100 (decimal) = 64 (hexadecimal) = 110 0100 (binary)

2) Negative number: 2^{18} minus this number in binary expression exp. -100 (decimal)

$$2^{18} - 100 = 262044 \text{ (decimal)} = 3FF9C \text{ (hexadecimal)} = 11 1111 1111 1001 1100 \text{ (binary)}$$

2. Charge Pump and Loop Filter

The AK1541 has two charge pumps; Charge Pump 1 for normal operation and Charge Pump 2 for Fast Lockup.

The internal timer is used to switch those two charge pumps to achieve a fast lock PLL. The loop filter is external and connected to [CP], [SWIN] and [CPZ] pins.

The [CPZ] pin should be connected to the R2 and C2, which are intermediate nodes, even if the Fast Lockup is not used. Therefore, R2 must be connected to the [CP] pin, while C2 must be connected to the ground.

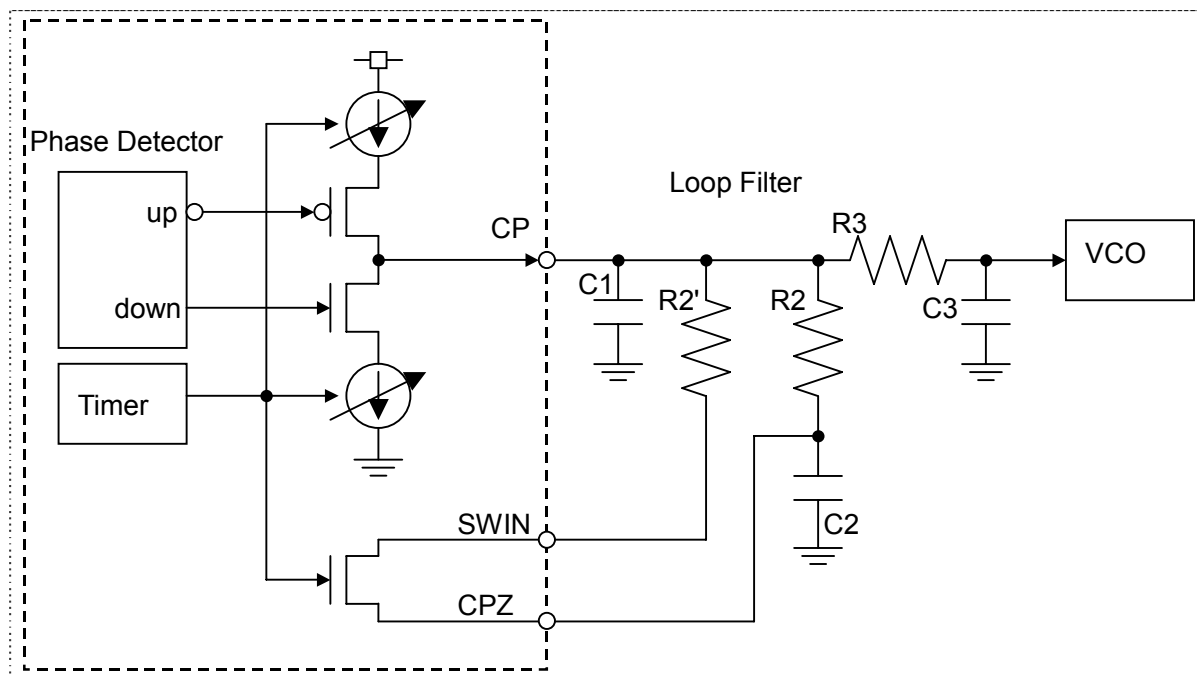

Fig. 5 Loop Filter Schematic

3. Fast Lockup Mode

Setting D[16] = {FASTEN} in <Address4> to "1" enables the Fast Lock Up mode for the AK1541.

Changing a frequency setting(The frequency is changed at the rising edge of [LE] when <Address1> and <Address2> are accessed.) or [PDN2] pin is set "Low" to "High" with {FASTEN}=1 enables the Fast Lockup mode. The loop filter switch turns ON during the timer period specified by the counter value in D[12:0] = {FAST[12:0]} in <Address4>, and the charge pump for the Fast Lockup mode (Charge Pump 2) is enabled. After the timer period elapsed, the loop filter switch turns OFF. The charge pump for normal operation (Charge Pump 1) is enabled..

D[12:0] = {FAST[12:0]} in <Address4> is used to set the timer period for this mode.

The following formula is used to calculate the time period:

$$\text{Phase detector frequency cycle} \times \text{counter value set in } \{FAST[12:0]\}$$

The charge pump current can be changed with the register setting in 16 steps in normal operation (Charge Pump 1) and 8 steps in the Fast Lockup operation (Charge Pump 2).

The charge pump current for normal operation (Charge Pump 1) is determined by the setting in {CP1[3:0]}, which is a 4-bit address of D[18:15] in <Address2>, and a value of the resistance connected to the [BIAS] pin (19). The following formulas show the relationship between the resistance value, the register setting and the electric current value.

$$\text{Charge Pump 1 minimum current (CP1_min)} = 0.285 / \text{Resistance connected to the [BIAS] pin (19)}$$

$$\text{Charge Pump 1 current} = \text{CP1_min} \times (\text{Charge Pump 1 setting} + 1)$$

The charge pump current for the Fast Lockup mode operation (Charge Pump 2 current) is determined by the setting in {CP2[2:0]}, which is a 3-bit address of D[15:13] in <Address4>, and a value of the resistance connected to the BIAS pin. The following formula show the relationship between the resistance value, the register setting and the electric current value.

$$\text{Charge Pump 2 minimum current (CP2_min)} = 5.7 / \text{Resistance connected to the [BIAS] pin}$$

$$\text{Charge Pump 2 minimum current (CP2_min)} = \text{CP2_min} \times (\text{Charge Pump 2 setting} + 4)$$

The allowed range value for the resistance (connected to the [BIAS] pin (19)) is from 33 to 22 [kΩ] for both normal and Fast Lockup mode operations. For details of current settings, see "10. Register Functional Description".

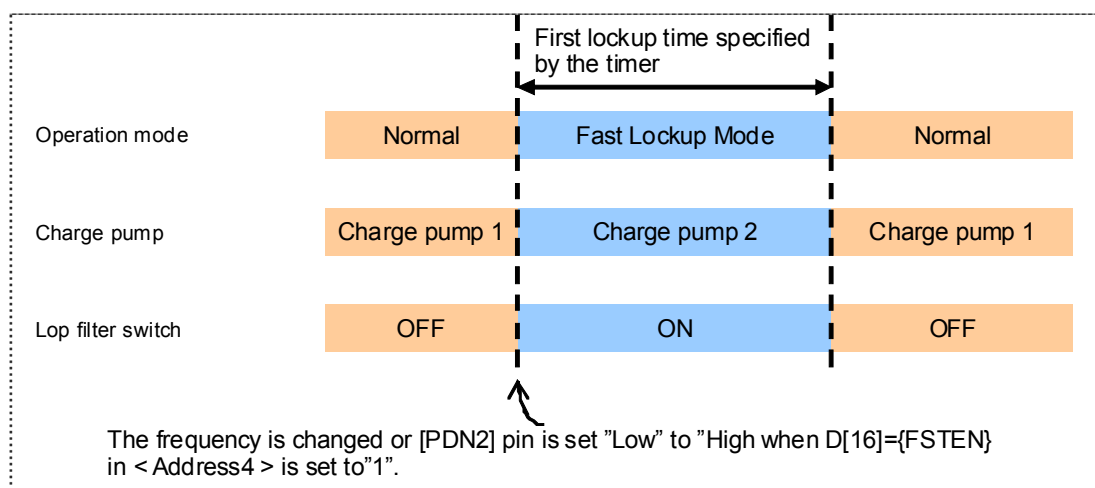

Fig. 6 Timing Chart for Fast Lockup Mode

4. Lock Detect (LD) Signal

In the AK1541, "lock detect" output can be selected by $D[11] = \{LD\}$ in $\langle \text{Address3} \rangle$. When $D[11]$ is set to "1" The phase detector outputs provides a phase detection status as an analog level (comparison result). This is called analog lock detect.

When $D[11]$ is set to "0", the lock detect signal is output according to the on-chip logic. This is called digital lock detect.

4.1 Analog Lock Detect

In analog lock detect, the phase detector output comes from the [LD] pin.

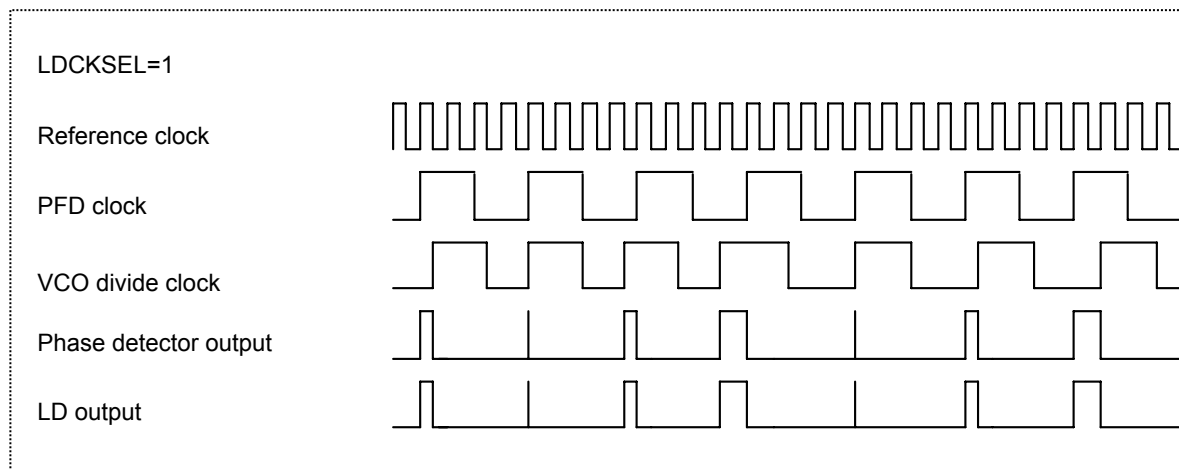

Fig. 7 Analog Lock Detect Operations

4.2 Digital Lock Detect

The accuracy of the phase detect is set by {LDCKSEL[1:0]}.

{LDCKSEL[1:0]} is set to 0: $T = \text{REFIN cycle}$

{LDCKSEL[1:0]} is set to 1: $T = \text{REFIN cycle} \times 2$ (This cannot be used for the reference dividing ratio ≤ 5 .)

{LDCKSEL[1:0]} is set to 2: $T = \text{REFIN cycle} \times 3$ (This cannot be used for the reference dividing ratio ≤ 6 .)

In the digital lock detect, the [LD] pin outputs is "Low" every time when the frequency is set. And the [LD] pin outputs is "High" (which means the locked state) when a phase error smaller than T is detected for 63 times consecutively. If the phase error is larger than T is detected for N times consecutively then the [LD] pin outputs is "High" and then the [LD] pin outputs is "Low" (which means the unlocked state).

Since the AK1541 is a Delta-Sigma Fractional-N type, a phase error up to 7 times larger than the VCO period frequency may occur in the phase detector. Therefore the {LDCKSEL[1:0]} setting should be large enough to cover the amplitude of the Delta-Sigma Fractional frequency. However, if the VCO frequency does not satisfy either of the following formula, the digital lock detect cannot be used. In such case, the analog lock detect should be used.

{DITH} = D14 in <Address3> is set to 1: $\text{VCO frequency} > [\text{REFIN}] \text{ pin input frequency} / \{ \{ \text{LDCKSEL}[1:0] \} \text{ setting} + 1 \} \times 7$

{DITH} = D14 in <Address3> is set to 0: $\text{VCO frequency} > [\text{REFIN}] \text{ pin input frequency} / \{ \{ \text{LDCKSEL}[1:0] \} \text{ setting} + 1 \} \times 4$

Example 1)

If [REFIN] pin input frequency = 33.6MHz, {DITH} = 1, {LDCKSEL[1:0]} = 2,

$33.6\text{MHz} / (2+1) \times 7 = 78.4\text{MHz}$

As a result, the digital lock detect cannot be used if the VCO frequency is equivalent to or smaller than 78.4MHz.

Example 2)

If [REFIN] pin input frequency = 33.6MHz, {DITH} = 0, {LDCKSEL[1:0]} = 1,

$33.6\text{MHz} / (1+1) \times 4 = 67.2\text{MHz}$

As a result, the digital lock detect cannot be used if the VCO frequency is equivalent to or smaller than 67.2MHz.

□ Setup example

DITH = D14 in <Address3> is set to 1:

	Available	Unavailable
VCO frequency ef- (at) the lower limit	180MHz	70MHz
[REFIN] pin input frequency	12.8MHz	32MHz
{LDCKSEL[1:0]}	0	2
Formula	$180\text{MHz} > 12.8 / (0+1) \times 7 = 89.6\text{MHz}$	$70\text{MHz} \succ (?) 32 / (2+1) \times 7 = 74.67\text{MHz}$

DITH = D14 in <Address3> is set to 0:

	Available	Unavailable
VCO frequency ef- (at) the lower limit	180MHz	60MHz
[REFIN] pin input frequency	12.8MHz	32MHz
{LDCKSEL[1:0]}	0	1
Formula	$180\text{MHz} > 12.8 / (0+1) \times 4 = 51.2\text{MHz}$	$60\text{MHz} \succ (?) 32 / (1+1) \times 4 = 64\text{MHz}$

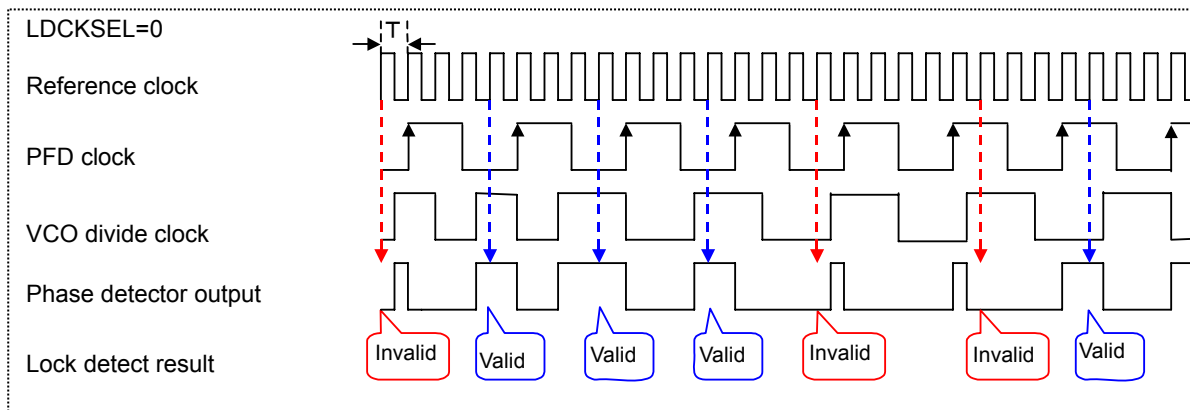

Fig. 8 Digital Lock Detect Operation

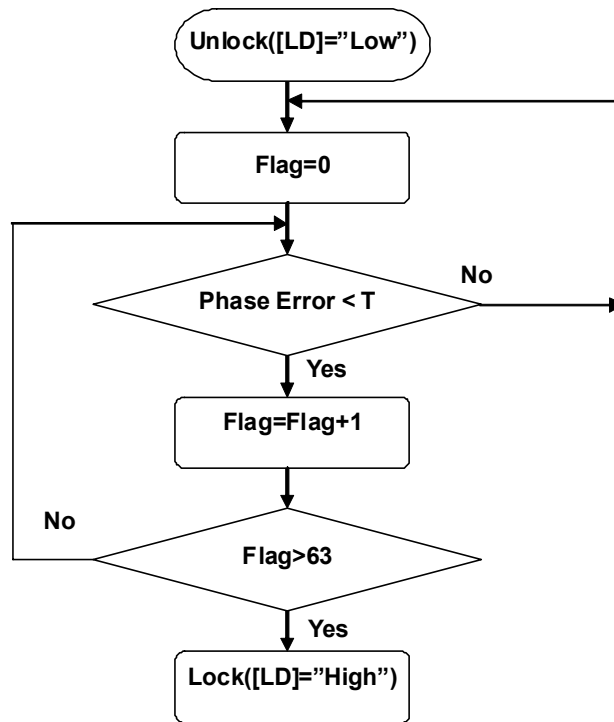

Fig. 9 Transition Flow Chart: Unlock State to Lock State

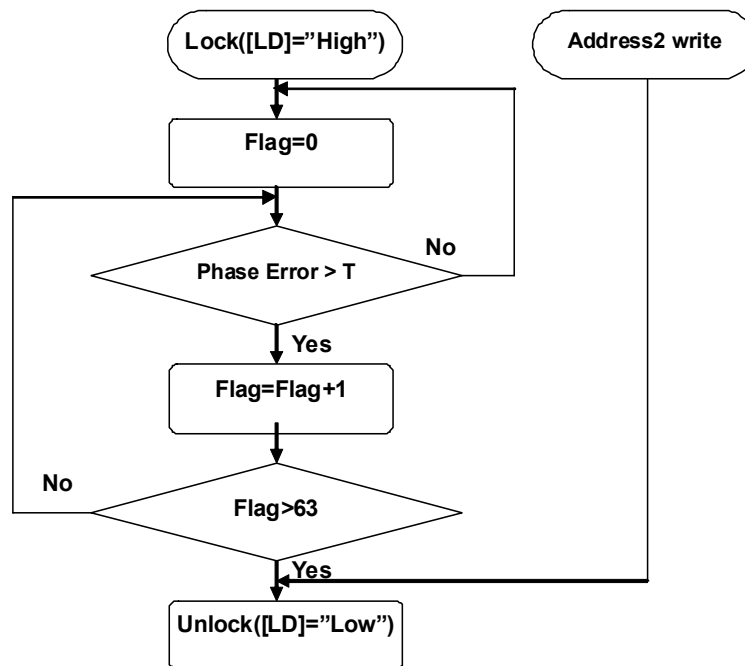

Fig. 10 Transition Flow Chart: Lock State to Unlock State

5. Reference Input

The reference input can be set with a dividing number in the range of 4 to 255 using {R[7:0]}, which is a 8-bit address in <Address3>. A dividing number from 0 to 3 cannot be set.

6. Prescaler and Swallow Counter

The dual modular prescaler ($P/P + 1$) and the swallow counter are used to provide a large dividing ratio.

The prescaler is set by {PRE[1:0]}, which is a 2-bit address in <Address3>.

When {PRE[1:0]} = "00", $P = 4$ is selected and then an integer from 89 to 8191 can be set.

When {PRE[1:0]} = "01", $P = 8$ is selected and then an integer from 201 to 16383 can be set.

When {PRE[1:0]} = "10" or "11", $P = 16$ is selected and then an integer from 521 to 32767 can be set.

For details of how to calculate an integer, see the section "Frequency Setup" in "8. Block Functional Description".

7. Power Save Mode

The AK1541 can be operated in the power-down or power-save mode as necessary by using the external control pins [PDN1] and [PDN2].

- Power On

See "13. Power-up Sequence".

- Normal Operation

Pin name		State
PDN1	PDN2	
0	0	Power down
0	1	Prohibited
1	0	Power save (Note 1) and Note 2)
1	1	Normal Operation

Note 1) Register setup can be made 50us after [PDN1] is set to "High". The charge pump is in the Hi-Z state.

Note 2) Register settings are maintained when [PDN2] is set to "Low" during normal operation.

9. Register Map

Name	Data	Address			
Num	D19~D0	0	0	0	1
Int		0	0	1	0
Div		0	0	1	1
Cp_fast		0	1	0	0

Name	D19	D18	D17	D16	D15	D14	D13	D12	D11	D10	D9	D8	D7	D6	D5	D4	D3	D2	D1	D0	Address
Num	-	-	NUM [17]	NUM [16]	NUM [15]	NUM [14]	NUM [13]	NUM [12]	NUM [11]	NUM [10]	NUM [9]	NUM [8]	NUM [7]	NUM [6]	NUM [5]	NUM [4]	NUM [3]	NUM [2]	NUM [1]	NUM [0]	0x01
Int	-	CP1 [3]	CP1 [2]	CP1 [1]	CP1 [0]	INT [14]	INT [13]	INT [12]	INT [11]	INT [10]	INT [9]	INT [8]	INT [7]	INT [6]	INT [5]	INT [4]	INT [3]	INT [2]	INT [1]	INT [0]	0x02
Div	-	-	-	-	CP HiZ	DITH	LDCK SEL[1]	LDCK SEL[0]	LD	CP POLA	PRE [1]	PRE [0]	R [7]	R [6]	R [5]	R [4]	R [3]	R [2]	R [1]	R [0]	0x03
Cp_fast	-	-	-	FAST EN	CP2 [2]	CP2 [1]	CP2 [0]	FAST [12]	FAST [11]	FAST [10]	FAST [9]	FAST [8]	FAST [7]	FAST [6]	FAST [5]	FAST [4]	FAST [3]	FAST [2]	FAST [1]	FAST [0]	0x04

-: Don't Care.

Note 1) Writing into address 0x01 is enabled when writing into address 0x02 is performed. Be sure to write into address 0x01 first and then address 0x02.

Note 2) The initial register values are not defined. Therefore, even after [PDN1] is set to "High", each bit value remains undefined. In order to set all register values, it is required to write the data in all addresses of the register.

10. Register Functional Description

< Address1:Num >

D19	D18	D[17:0]	Address
-	-	NUM[17:0]	0001

Note) Writing into address 0x01 is enabled when writing into address 0x02 is performed.

NUM[17:0] : Set the numerator in 2's complementary representation.

< Address2:Int >

D19	D[18:15]	D[14:0]	Address
-	CP1[3:0]	INT[14:0]	0010

CP1[3:0]: Sets the current value for the charge pump in normal operation (Charge Pump 1).

The minimum current value for Charge Pump 1 (CP1_min) is determined by the following formula:

$$CP1_min = 0.285 / \text{Resistance connected to the [BIAS] pin}$$

$$\text{Charge Pump 1 current} = CP1_min \times (CP1 \text{ setting} + 1)$$

	Charge Pump 1 current [μ A]		
CP1[3:0]	33k Ω	27 k Ω	22 k Ω
0000	8.6	10.6	13.0
0001	17.3	21.1	25.9
0010	25.9	31.7	38.9
0011	34.5	42.2	51.8
0100	43.2	52.8	64.8
0101	51.8	63.3	77.7
0110	60.5	73.9	90.7
0111	69.1	84.4	103.6
1000	77.7	95.0	116.6
1001	86.4	105.6	129.5
1010	95.0	116.1	142.5
1011	103.6	126.7	155.5
1100	112.3	137.2	168.4
1101	120.9	147.8	181.4
1110	129.5	158.3	194.3
1111	138.2	168.9	207.3

INT[14:0] : Sets the integer.

< Address3:Div >

D19	D18	D17	D16	D15	D14	D[13:12]	D11	D10	D[9:8]	D[7:0]	Address
-	-	-	-	CPHI	DITH	LDCKSEL[1:0]	LD	CPPOLA	PRE[1:0]	R[7:0]	0011

CPHIZ: Selects normal or TRI-STATE for the CP1/CP2 output.

D15	Function	Remarks
0	Charge pumps are activated.	Use this setting for normal operation.
1	TRI-STATE	Note 1)

Note 1) The charge pump output is put in the high-impedance (Hi-Z) state.

DITH: Selects dithering ON or OFF for a delta-sigma circuit.

D31	Function	Remarks
0	DITH OFF	
1	DITH ON	Recommended

It is used to control the turning On or Off dithering to cancel cyclical noise.

In normal operation, "1"= DITH ON is recommended.

LDCKSEL[1:0] : Sets a phase error value for lock detect.

D13	D12	Function	Remarks
0	0	1 cycle of the REFIN clock	
0	1	2 cycles of the REFIN clock	
1	0	3 cycles of the REFIN clock	
1	1	Prohibited	

For detailed functional descriptions, see the section "Lock Detect (LD) Signal" in "8. Block Functional Description".

LD: Selects analog or digital for the lock detect.

D11	Function	Remarks
0	Digital Lock Detect	
1	Analog Lock Detect	

For detailed functional descriptions, see the section "Lock Detect (LD) Signal" in "8. Block Functional Description".

CPPOLA: Selects positive or negative output polarity for Charge Pump 1 and Charge Pump 2.

D10	Function	Remarks
0	Positive	
1	Negative	

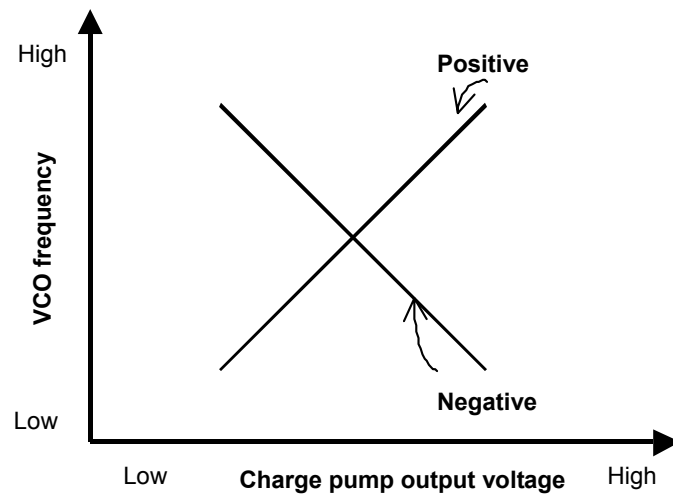

Fig. 11 Charge Pump slope Polarity

PRE[1:0] : Selects a dividing ratio for the prescaler.

D9	D8	Function	Remarks
0	0	P=4	
0	1	P=8	
1	0	P=16	
1	1	P=16	

R[7:0]: Sets a dividing ratio for the reference clock.

This can be set in the range from 4 (4 divisions) to 255 (255 divisions). 0, 1, 2 or 3 cannot be set.

D7	D6	D5	D4	D3	D2	D1	D0	Function	Remarks
0	0	0	0	0	0	0	0	0	Prohibited
0	0	0	0	0	0	0	1	1	Prohibited
0	0	0	0	0	0	1	0	2	Prohibited
0	0	0	0	0	0	1	1	3	Prohibited
DATA									
1	1	1	1	1	1	0	1	253	
1	1	1	1	1	1	1	0	254	
1	1	1	1	1	1	1	1	255	

< Address4:Cp_fast >

D19	D18	D17	D16	D[15:13]	D[12:0]	Address
-	-	-	FASTEN	CP2[2:0]	FAST[12:0]	0100

FASTEN: Enables or disables the Fast Lockup mode.

D16	Function	Remarks
0	The switchover settings specified in CP2[2:0] and FAST[12:0] are disabled.	
1	The switchover settings specified in CP2[2:0] and FAST[12:0] are enabled.	

CP2[2:0]: Sets the current value for the charge pump for the Fast Lockup mode (Charge Pump 2).

The minimum Charge Pump 2 current (CP2_min) is determined by the following formula:

$$CP2_min = 5.7 / \text{Resistance connected to the [BIAS] pin}$$

$$\text{Charge Pump 2 minimum current (CP2_min)} = CP2_min \times (CP2 \text{ setting} + 4)$$

CP2[2:0]	Charge Pump 2 current [mA]		
	33kΩ	27 kΩ	22 kΩ
000	0.69	0.84	1.04
001	0.86	1.06	1.30
010	1.04	1.27	1.55
011	1.21	1.48	1.81
100	1.38	1.69	2.07
101	1.55	1.90	2.33
110	1.73	2.11	2.59
111	1.90	2.32	2.85

FAST[12:0] : Sets the FAST counter value.

A decimal number from 1 to 8191 can be set. This counter value is used to set the time period during which the charge pump for the Fast Lockup mode is ON.

The charge pump for the Fast Lockup mode is turned OFF after the time period calculated by [this count value x the reference clock cycle]. 0 cannot be set.

D12	D11	D10	D9	D8	D7	D6	D5	D4	D3	D2	D1	D0	Function	Remarks
0	0	0	0	0	0	0	0	0	0	0	0	0	0	Prohibited
0	0	0	0	0	0	0	0	0	0	0	0	1	1 Dec	
0	0	0	0	0	0	0	0	0	0	0	1	0	2 Dec	
DATA														
1	1	1	1	1	1	1	1	1	1	1	0	1	8189 Dec	
1	1	1	1	1	1	1	1	1	1	1	1	0	8190 Dec	
1	1	1	1	1	1	1	1	1	1	1	1	1	8191 Dec	

11. IC Interface Schematic

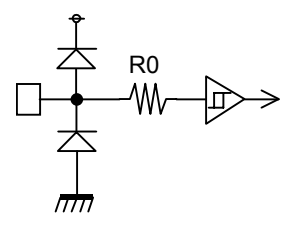
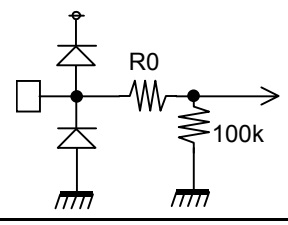
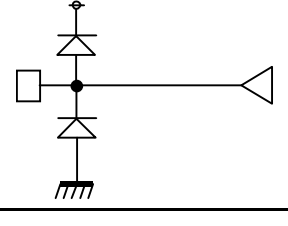
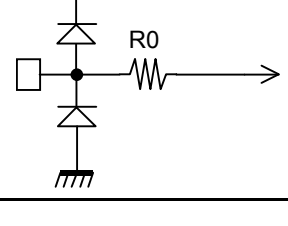
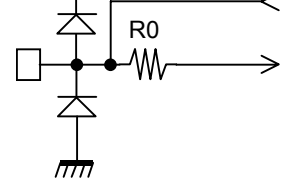
No.	Name	I/O	R0(Ω)	Cur(μ A)	Function
4	LE	I	300		Digital input pins 
5	DATA	I	300		
6	CLK	I	300		
8	PDN2	I	300		
9	PDN1	I	300		
2	TEST4	I	300		Digital input pins Pull-Down 
3	TEST1	I	300		
11	TEST2	I	300		
12	TEST3	I	300		
7	LD	O			Digital output pin 
10	REFIN	I	300		Analog input pin 
13	VREF1	IO	300		Analog I/O pin 
15	VREF2	IO	300		
19	BIAS	IO	300		
22	CPZ	IO	300		

No.	Name	I/O	R0(Ω)	Cur(μ A)	Function
23	SWIN	I			Analog input pin
21	CP	O			Analog output pin
16	RFINN	I	12k	20uA	Analog input pin(RF signal input)
17	RFINP	I	12k	20uA	

12. Recommended Connection Schematic for Off-Chip Components

1. PVDD, CPVDD

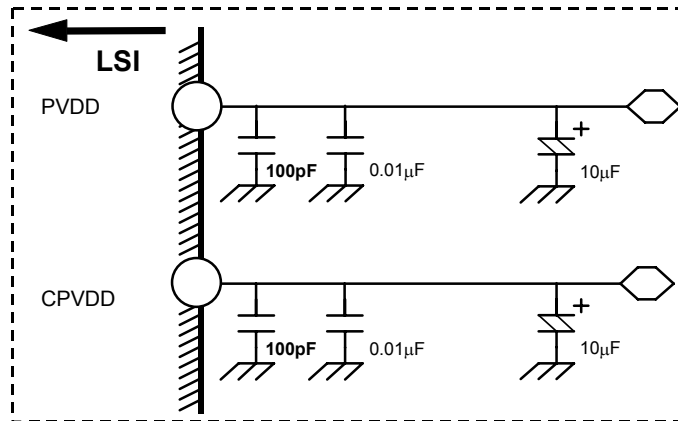

2. VREF1, VREF2

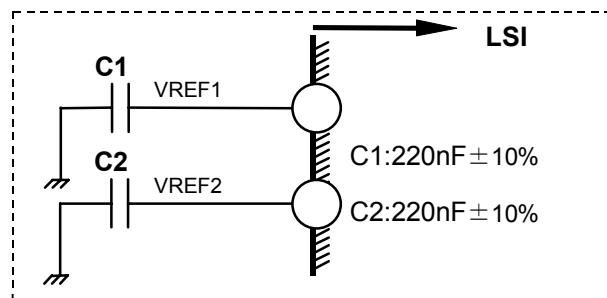

3. TEST [1,2,3,4]

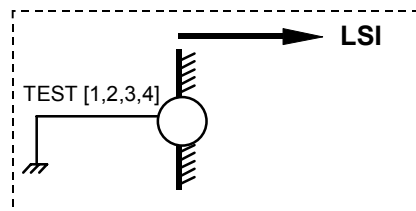

4. REFIN

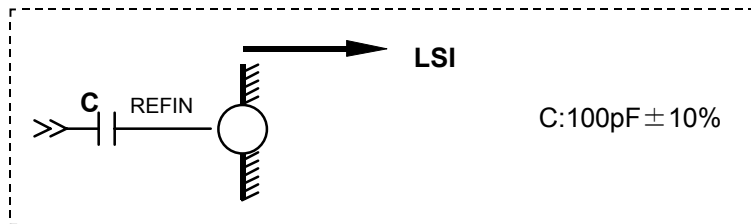

5. RFINP, RFINN

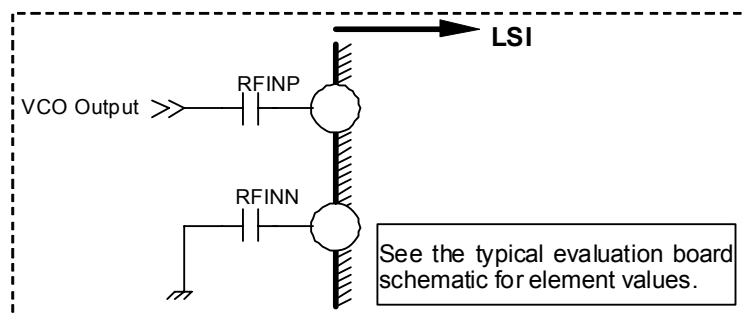

6. BIAS

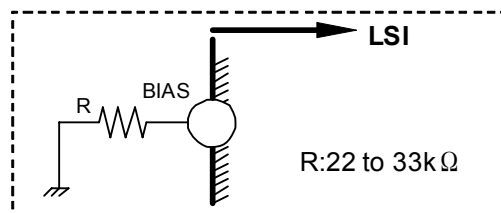

13. Power-up Sequence

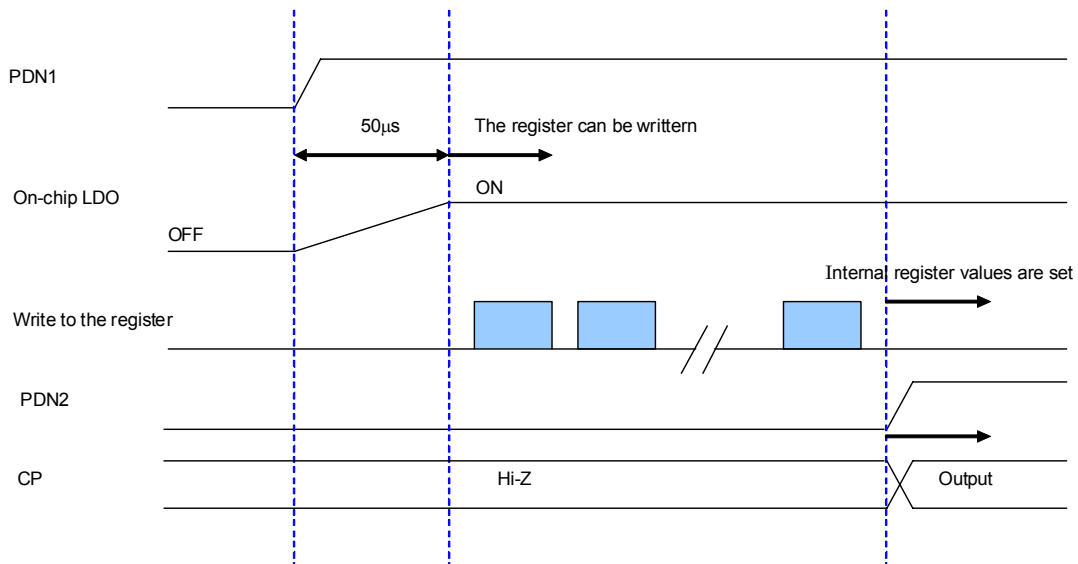

Fig. 12 Recommended Power Sequence

Note 1) The initial register values are not defined. Therefore, even after [PDN1] is set to "High", each bit value remains undefined. In order to set all register values, it is required to write the data in all addresses of the register.

14. Typical Evaluation Board Schematic

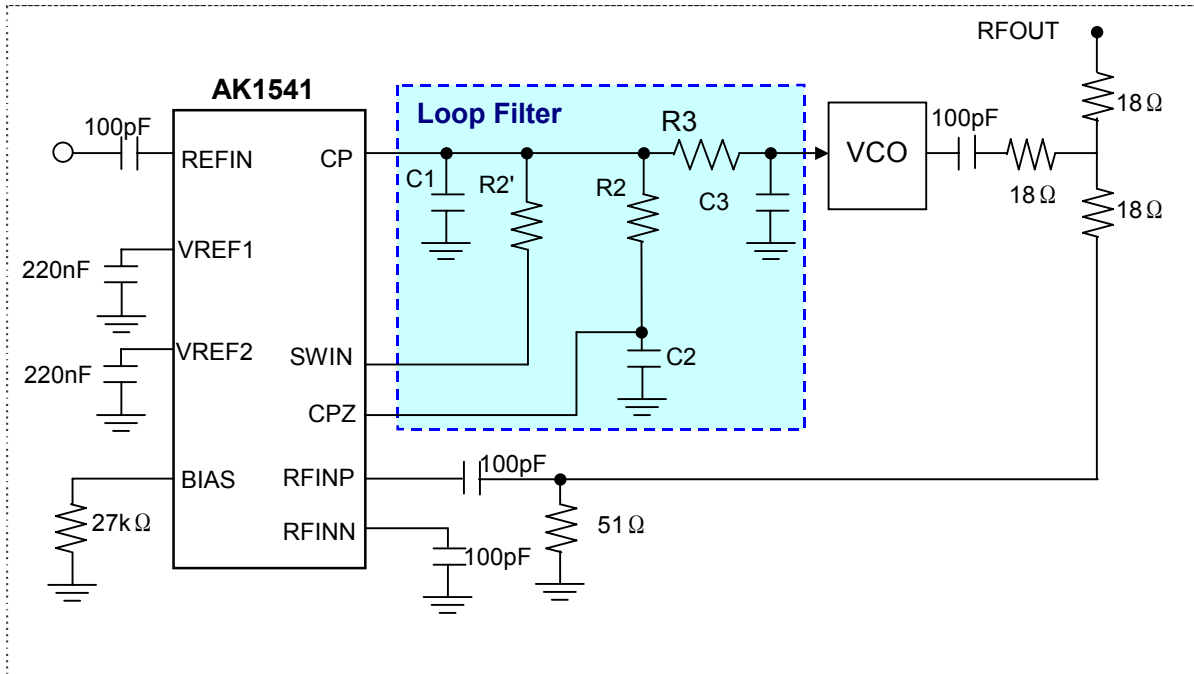

Fig. 13 Typical Evaluation Board Schematic

The input voltage from the [CPZ] pin is used in the internal circuit. The [CPZ] pin must not be open even when the fast lockup feature is unused. For the output destination from the [CPZ] pin, see “P.12 Fig.5 Loop Filter Schematic”. The [SWIN] pin could be open even when the first lockup feature is not used.

15. Block Diagram by Power Supply

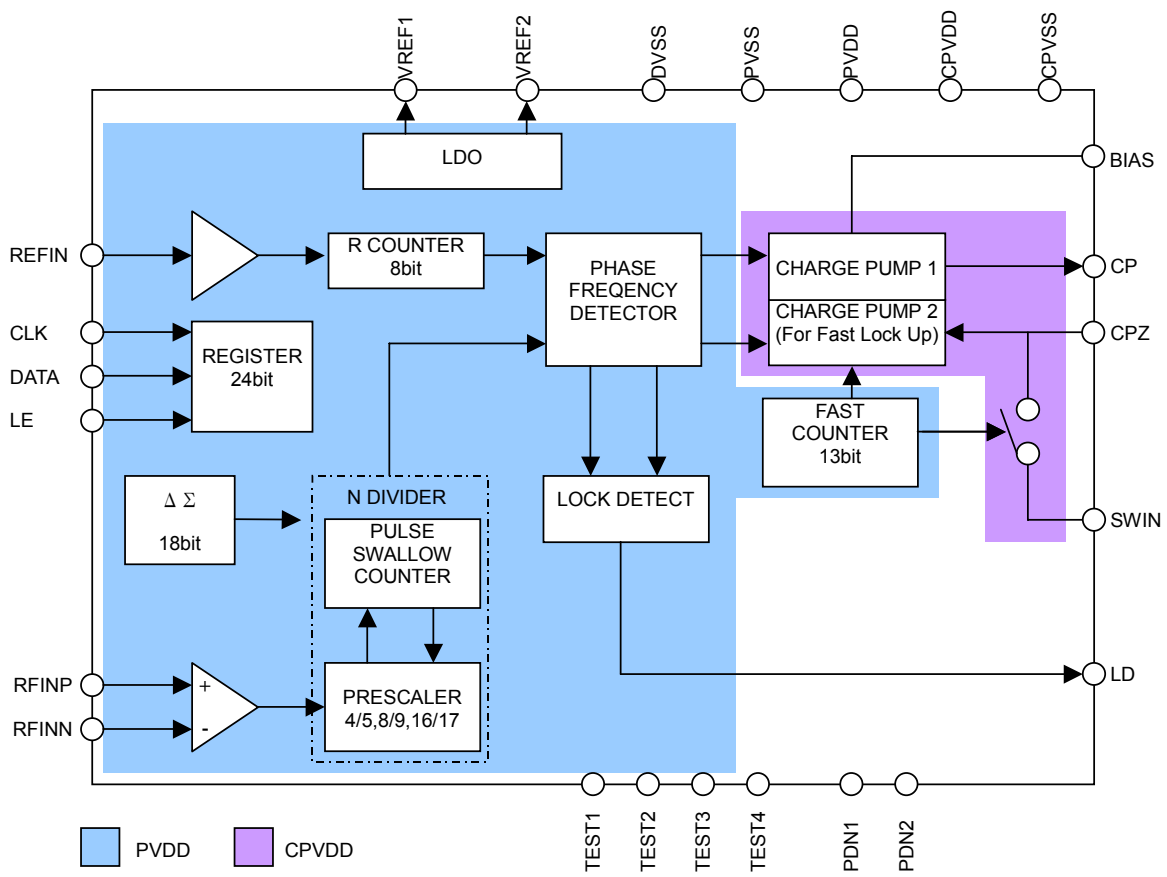
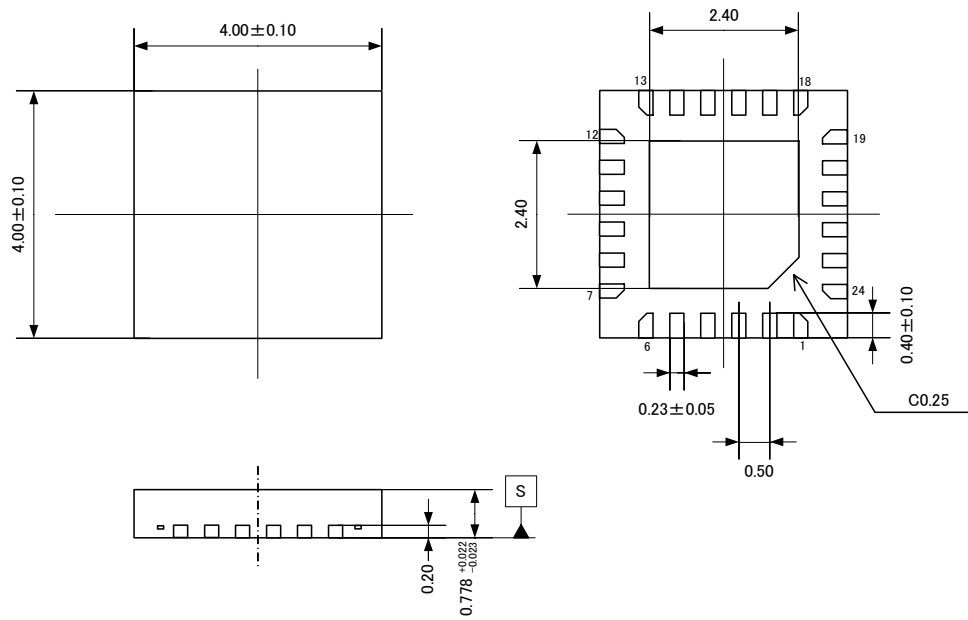

Fig. 14 Block Diagram by Power Supply

16. Outer Dimensions

Fig. 15 Outer Dimensions

Note) It is recommended to connect the exposed pad (the center of the back of the package) to ground, although it will not make any impact on the electrical characteristics if the pad is open.

17. Marking

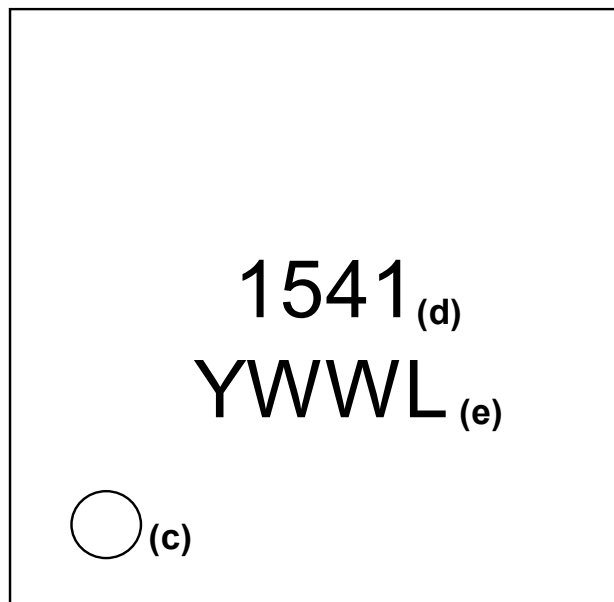
- (a) Style : QFN
(b) Number of pins : 24
(c) 1 pin marking: : ○
(d) Product number : 1541
(e) Date code : YWWL (4 digits)
- Y: Lower 1 digit of calendar year (Year 2009 → 9, 2010 → 0 ...)
WW: Week
L: Lot identification, given to each product lot which is made in a week
→ LOT ID is given in alphabetical order (A, B, C...).

**Fig. 16 Marking**

IMPORTANT NOTICE

- These products and their specifications are subject to change without notice. When you consider any use or application of these products, please make inquiries the sales office of Asahi Kasei Microdevices Corporation (AKM) or authorized distributors as to current status of the products.
- Descriptions of external circuits, application circuits, software and other related information contained in this document are provided only to illustrate the operation and application examples of the semiconductor products. You are fully responsible for the incorporation of these external circuits, application circuits, software and other related information in the design of your equipments. AKM assumes no responsibility for any losses incurred by you or third parties arising from the use of these information herein. AKM assumes no liability for infringement of any patent, intellectual property, or other rights in the application or use of such information contained herein.
- Any export of these products, or devices or systems containing them, may require an export license or other official approval under the law and regulations of the country of export pertaining to customs and tariffs, currency exchange, or strategic materials.
- AKM products are neither intended nor authorized for use as critical components^{Note1)} in any safety, life support, or other hazard related device or system^{Note2)}, and AKM assumes no responsibility for such use, except for the use approved with the express written consent by Representative Director of AKM. As used here:
 - Note1) A critical component is one whose failure to function or perform may reasonably be expected to result, whether directly or indirectly, in the loss of the safety or effectiveness of the device or system containing it, and which must therefore meet very high standards of performance and reliability.
 - Note2) A hazard related device or system is one designed or intended for life support or maintenance of safety or for applications in medicine, aerospace, nuclear energy, or other fields, in which its failure to function or perform may reasonably be expected to result in loss of life or in significant injury or damage to person or property.
- It is the responsibility of the buyer or distributor of AKM products, who distributes, disposes of, or otherwise places the product with a third party, to notify such third party in advance of the above content and conditions, and the buyer or distributor agrees to assume any and all responsibility and liability for and hold AKM harmless from any and all claims arising from the use of said product in the absence of such notification.