



AK4125

192kHz / 24Bit High Performance Asynchronous SRC

GENERAL DESCRIPTION

The AK4125 is a stereo digital sample rate converter (SRC). The input sample rate ranges from 8kHz to 216kHz. The output sample rate is from 8kHz to 216kHz. The system can take very simple configuration because the AK4125 has an internal PLL and does not need any master clock at slave mode. The AK4125 is suitable for the application interfacing to different sample rates such as high-end Car Audio and DVD recorder.

FEATURES

1. SRC

- Asynchronous Sample Rate Converter
- Input Sample Rate Range (fsi): 8kHz ~ 216kHz
- Output Sample Rate Range (fso): 8kHz ~ 216kHz
- Input to Output Sample Rate Ratio: 1/6 to 6
- THD+N: -130dB
- Dynamic Range: 140dB (A-weighted)
- I/F format: MSB justified, LSB justified and I²S compatible
- PLL for Internal Operation Clock
- Clock for Master mode: 128/192/256/384/512/768fsi, 128/192/256/384/512/768fso
- SRC Bypass mode
- Soft Mute Function

2. Power Supply

- AVDD, DVDD: 3.0 ~ 3.6V (typ. 3.3V)

3. Ta = -40 ~ 85°C

4. Package: 30pin VSOP

5. AK4124 Pin-compatible

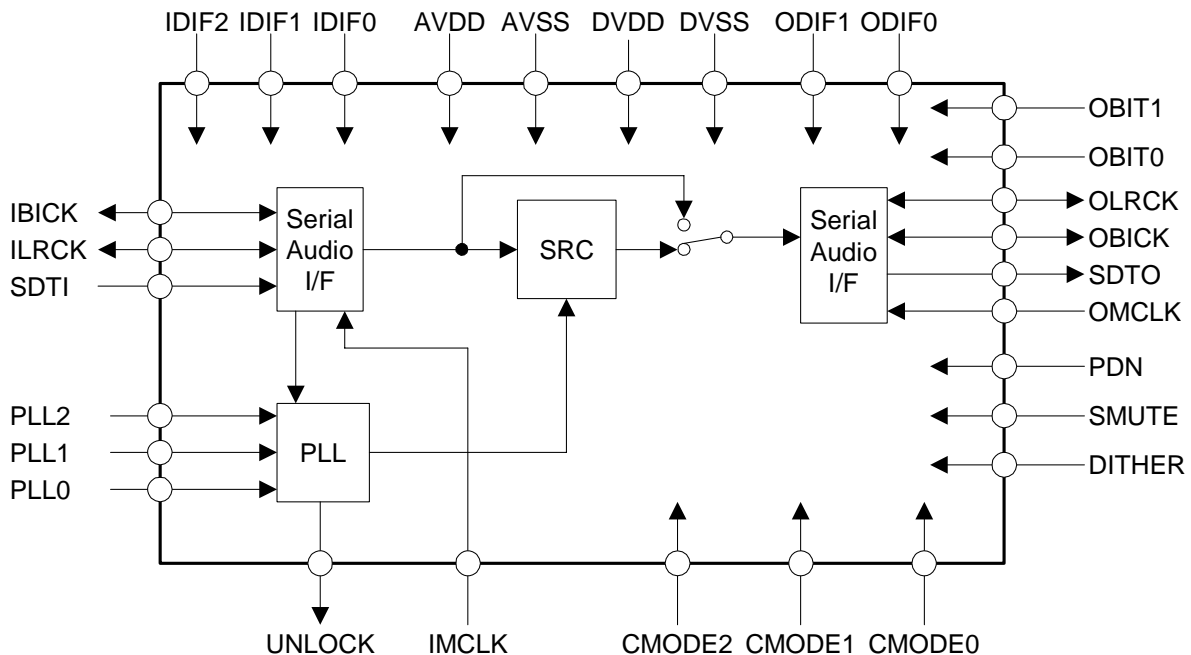

■ Ordering Guide

AK4125VF
AKD4125

-40 ~ +85°C
Evaluation Board for AK4125

30pin VSOP (0.65mm pitch)

■ Pin Layout

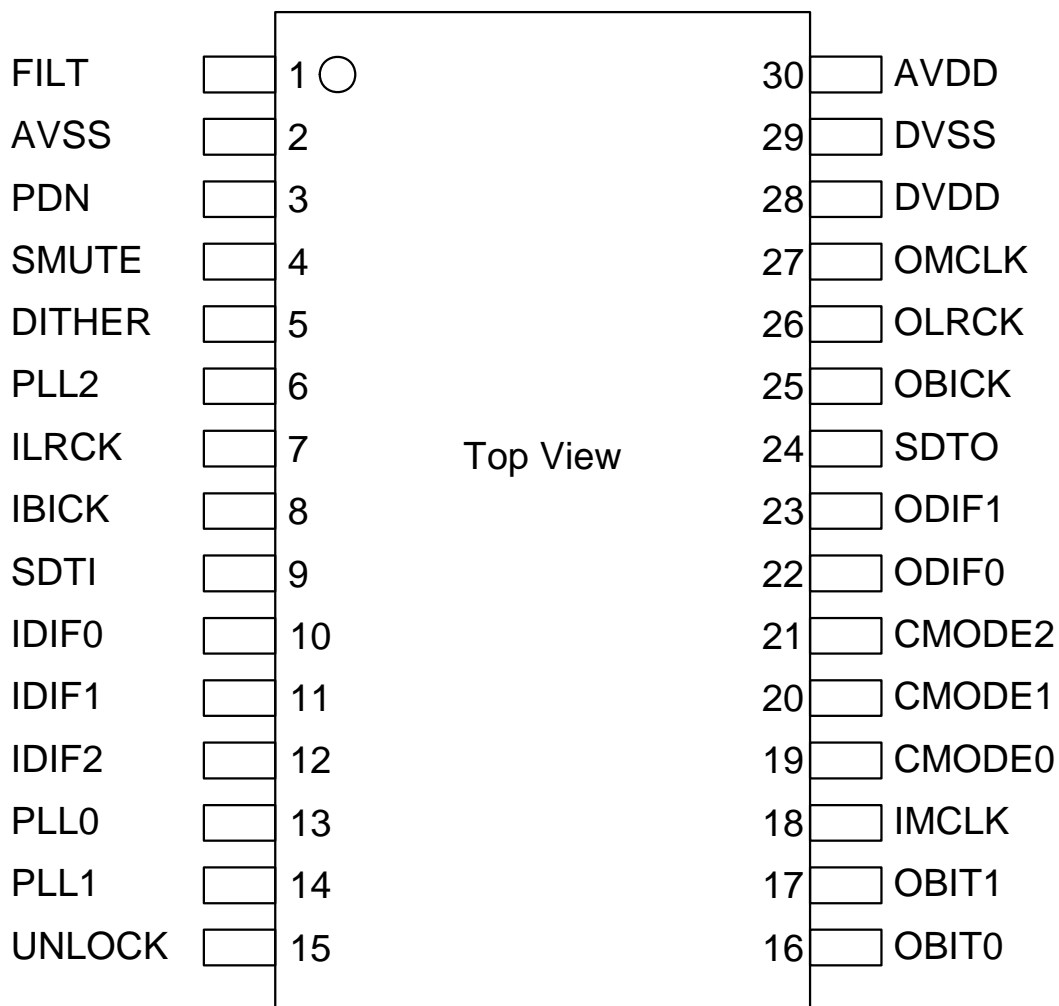

■ Compatibility with AK4124

		AK4124	AK4125
Digital Filter Passband	$0.985 \leq \text{FSO/FSI} \leq 6.000$	0.4583FSI	←
	$0.905 \leq \text{FSO/FSI} < 0.985$	0.4167FSI	←
	$0.714 \leq \text{FSO/FSI} < 0.905$	0.3195FSI	←
	$0.656 \leq \text{FSO/FSI} < 0.714$	0.2852FSI	←
	$0.536 \leq \text{FSO/FSI} < 0.656$	0.2182FSI	←
	$0.492 \leq \text{FSO/FSI} < 0.536$	0.1982FSI	0.2177FSI
	$0.452 \leq \text{FSO/FSI} < 0.492$	0.1740FSI	0.1948FSI
	$0.357 \leq \text{FSO/FSI} < 0.452$	0.1212FSI	0.1458FSI
	$0.324 \leq \text{FSO/FSI} < 0.357$	0.1072FSI	0.1302FSI
	$0.246 \leq \text{FSO/FSI} < 0.324$	0.0595FSI	0.0917FSI
	$0.226 \leq \text{FSO/FSI} < 0.246$	0.0484FSI	0.0826FSI
	$0.1667 \leq \text{FSO/FSI} < 0.226$	0.0182FSI	0.0583FSI

Refer to [Table 8](#) for the detail of filter response.

PIN/FUNCTION

No.	Pin Name	I/O	Function
1	FILT	O	PLL Loop Filter Pin
2	AVSS	-	Analog Ground Pin
3	PDN	I	Power-Down Mode Pin “H”: Power up, “L”: Power down reset and initializes the control register.
4	SMUTE	I	Soft Mute Pin “H” : Soft Mute, “L” : Normal Operation
5	DITHER	I	Dither Enable Pin “H” : Dither ON, “L” : Dither OFF
6	PLL2	I	PLL Mode Select 2 Pin
7	ILRCK	I/O	Input Channel Clock Pin
8	IBICK	I/O	Audio Serial Data Clock Pin
9	SDTI	I	Audio Serial Data Input Pin
10	IDIF0	I	Audio Interface Format 0 Pin for Input PORT
11	IDIF1	I	Audio Interface Format 1 Pin for Input PORT
12	IDIF2	I	Audio Interface Format 2 Pin for Input PORT
13	PLL0	I	PLL Mode Select 0 Pin
14	PLL1	I	PLL Mode Select 1 Pin
15	UNLOCK	O	Unlock Status Pin
16	OBIT0	I	Bit Length Select 0 Pin for Output Data
17	OBIT1	I	Bit Length Select 1 Pin for Output Data
18	IMCLK	I	Master Clock Input Pin for Input PORT
19	CMODE0	I	Clock Mode Select 0 Pin
20	CMODE1	I	Clock Mode Select 1 Pin
21	CMODE2	I	Clock Mode Select 2 Pin
22	ODIF0	I	Audio Interface Format 0 Pin for Output PORT
23	ODIF1	I	Audio Interface Format 1 Pin for Output PORT
24	SDTO	O	Audio Serial Data Output Pin for Output PORT
25	OBICK	I/O	Audio Serial Data Clock Pin for Output PORT
26	OLRCK	I/O	Output Channel Clock Pin for Output PORT
27	OMCLK	I	Master Clock Input Pin for Output PORT
28	DVDD	-	Digital Power Supply Pin, 3.0 ~ 3.6V
29	DVSS	-	Digital Ground Pin
30	AVDD	-	Analog Power Supply Pin, 3.0 ~ 3.6V

Note: All input pins must not be left floating.

■ Handling of Unused pins

The unused digital I/O pins should be processed appropriately as below.

Classification	Pin Name	Setting
Analog	FILT	This pin should be open.
Digital	SMUTE, DITHER	These pins should be connected to DVSS.
	IMCLK, OMCLK	These pins should be connected to DVSS in slave mode.
	UNLOCK	This pin should be open.

ABSOLUTE MAXIMUM RATINGS

(AVSS=DVSS=0V; Note 1)

Parameter		Symbol	min	max	Units
Power Supplies:	Analog	AVDD	-0.3	4.6	V
	Digital	DVDD	-0.3	4.6	V
	AVSS – DVSS (Note 2)	Δ GND	-	0.3	V
Input Current, Any Pin Except Supplies		IIN	-	\pm 10	mA
Digital Input Voltage		VIND	-0.3	DVDD+0.3	V
Ambient Temperature (Power applied)		Ta	-40	85	°C
Storage Temperature		Tstg	-65	150	°C

Note 1. All voltages with respect to ground.

Note 2. AVSS and DVSS must be connected to the same ground.

WARNING: Operation at or beyond these limits may result in permanent damage to the device.

Normal operation is not guaranteed at these extremes.

RECOMMENDED OPERATING CONDITIONS

(AVSS=DVSS=0V; Note 1)

Parameter		Symbol	min	typ	max	Units
Power Supplies (Note 3)	Analog	AVDD	3.0	3.3	3.6	V
	Digital	DVDD	3.0	3.3	AVDD	V

Note 1. All voltages with respect to ground.

Note 3. The power up sequence between AVDD and DVDD is not important.

WARNING: AKM assumes no responsibility for the usage beyond the conditions in this datasheet.

SRC CHARACTERISTICS

(Ta=25°C; AVDD=DVDD=3.3V; AVSS=DVSS=0V; Single Frequency = 1 kHz, data = 24bit; measurement bandwidth = 20Hz ~ FSO/2; unless otherwise specified.)

Parameter	Symbol	min	typ	max	Units
SRC Characteristics:					
Resolution				24	Bits
Input Sample Rate	FSI	8		216	kHz
Output Sample Rate	FSO	8		216	kHz
THD+N (Input = 1kHz, 0dBFS, Note 4)					
FSO/FSI = 44.1kHz/48kHz		-	-130	-	dB
FSO/FSI = 48kHz/44.1kHz		-	-124	-	dB
FSO/FSI = 48kHz/192kHz		-	-133	-	dB
FSO/FSI = 192kHz/48kHz		-	-124	-	dB
Worst Case (FSO/FSI = 32kHz/176.4kHz)		-	-	-91	dB
Dynamic Range (Input = 1kHz, -60dBFS, Note 4)					
FSO/FSI = 44.1kHz/48kHz		-	136	-	dB
FSO/FSI = 48kHz/44.1kHz		-	136	-	dB
FSO/FSI = 48kHz/192kHz		-	136	-	dB
FSO/FSI = 192kHz/48kHz		-	132	-	dB
Worst Case (FSO/FSI = 48kHz/32kHz)		132	-	-	dB
Dynamic Range (Input = 1kHz, -60dBFS, A-weighted, Note 4)					
FSO/FSI = 44.1kHz/48kHz		-	140	-	dB
Ratio between Input and Output Sample Rate	FSO/FSI	1/6		6	-

Note 4. Measured by Audio Precision System Two Cascade.

FILTER CHARACTERISTICS

(Ta=25°C; AVDD=DVDD=3.0 ~ 3.6V)

Parameter		Symbol	min	typ	max	Units
Digital Filter						
Passband -0.01dB	0.985 ≤ FSO/FSI ≤ 6.000	PB	0		0.4583FSI	kHz
	0.905 ≤ FSO/FSI < 0.985	PB	0		0.4167FSI	kHz
	0.714 ≤ FSO/FSI < 0.905	PB	0		0.3195FSI	kHz
	0.656 ≤ FSO/FSI < 0.714	PB	0		0.2852FSI	kHz
	0.536 ≤ FSO/FSI < 0.656	PB	0		0.2182FSI	kHz
	0.492 ≤ FSO/FSI < 0.536	PB	0		0.2177FSI	kHz
	0.452 ≤ FSO/FSI < 0.492	PB	0		0.1948FSI	kHz
	0.357 ≤ FSO/FSI < 0.452	PB	0		0.1458FSI	kHz
	0.324 ≤ FSO/FSI < 0.357	PB	0		0.1302FSI	kHz
	0.246 ≤ FSO/FSI < 0.324	PB	0		0.0917FSI	kHz
	0.226 ≤ FSO/FSI < 0.246	PB	0		0.0826FSI	kHz
	0.1667 ≤ FSO/FSI < 0.226	PB	0		0.0583FSI	kHz
Stopband	0.985 ≤ FSO/FSI ≤ 6.000	SB	0.5417FSI			kHz
	0.905 ≤ FSO/FSI < 0.985	SB	0.5021FSI			kHz
	0.714 ≤ FSO/FSI < 0.905	SB	0.3965FSI			kHz
	0.656 ≤ FSO/FSI < 0.714	SB	0.3643FSI			kHz
	0.536 ≤ FSO/FSI < 0.656	SB	0.2974FSI			kHz
	0.492 ≤ FSO/FSI < 0.536	SB	0.2813FSI			kHz
	0.452 ≤ FSO/FSI < 0.492	SB	0.2604FSI			kHz
	0.357 ≤ FSO/FSI < 0.452	SB	0.2116FSI			kHz
	0.324 ≤ FSO/FSI < 0.357	SB	0.1969FSI			kHz
	0.246 ≤ FSO/FSI < 0.324	SB	0.1573FSI			kHz
	0.226 ≤ FSO/FSI < 0.246	SB	0.1471FSI			kHz
	0.1667 ≤ FSO/FSI < 0.226	SB	0.1020FSI			kHz
Passband Ripple		PR			±0.01	dB
Stopband Attenuation	0.985 ≤ FSO/FSI ≤ 6.000	SA	121.2			dB
	0.905 ≤ FSO/FSI < 0.985	SA	121.4			dB
	0.714 ≤ FSO/FSI < 0.905	SA	115.3			dB
	0.656 ≤ FSO/FSI < 0.714	SA	116.9			dB
	0.536 ≤ FSO/FSI < 0.656	SA	114.6			dB
	0.492 ≤ FSO/FSI < 0.536	SA	100.2			dB
	0.452 ≤ FSO/FSI < 0.492	SA	103.3			dB
	0.357 ≤ FSO/FSI < 0.452	SA	102.0			dB
	0.324 ≤ FSO/FSI < 0.357	SA	103.6			dB
	0.246 ≤ FSO/FSI < 0.324	SA	104.0			dB
0.226 ≤ FSO/FSI < 0.246	SA	103.3			dB	
0.1667 ≤ FSO/FSI < 0.226	SA	73.2			dB	
Group Delay	(Note 5)	GD	-	56	-	1/fs

Note 5. This delay is the a period from the rising edge of ILRCK, just after the data is input, to the rising edge of OLRCK, just after the data is output, when there is no phase difference between ILRCK and OLRCK.

DC CHARACTERISTICS

(Ta=25°C; AVDD= DVDD=3.0 ~ 3.6V)

Parameter	Symbol	min	typ	max	Units
High-Level Input Voltage	VIH	70%DVDD	-	-	V
Low-Level Input Voltage	VIL	-	-	30%DVDD	V
High-Level Output Voltage (Iout=-400μA)	VOH	DVDD-0.4	-	-	V
Low-Level Output Voltage (Iout=400μA)	VOL	-	-	0.4	V
Input Leakage Current	Iin	-	-	±10	μA
Power Supplies					
Power Supply Current					
Normal operation (PDN pin = "H")					
FSI=FSO=48kHz at Slave Mode: AVDD=DVDD=3.3V					
FSI=FSO=192kHz at Master Mode: AVDD=DVDD=3.3V					
: AVDD=DVDD=3.6V					
Power down (PDN pin = "L") (Note 6)					
AVDD+DVDD					
			13		mA
			55		mA
				85	mA
			10	100	μA

Note 6. All digital input pins are held DVSS.

SWITCHING CHARACTERISTICS

(Ta=25°C; AVDD=DVDD=3.0 ~ 3.6V; CL=20pF)

Parameter	Symbol	min	typ	max	Units
Master Clock Timing					
Frequency	fCLK	1.024		41.472	MHz
Pulse Width Low	tCLKL	0.4/fCLK			ns
Pulse Width High	tCLKH	0.4/fCLK			ns
LRCK for Input data (ILRCK)					
Frequency	fs	8		216	kHz
Duty Cycle	Duty	48	50	52	%
			50		%
LRCK for Output data (OLRCK)					
Frequency	fs	8		216	kHz
Duty Cycle	Duty	48	50	52	%
			50		%
Audio Interface Timing					
Input PORT (Slave mode)					
IBICK Period (8kHz ~ 108kHz)	tBCK	1/128fs			ns
(108kHz ~ 216kHz)	tBCK	1/64fs			ns
IBICK Pulse Width Low	tBCKL	27			ns
Pulse Width High	tBCKH	27			ns
ILRCK Edge to IBICK “↑” (Note 7)	tLRB	15			ns
IBICK “↑” to ILRCK Edge (Note 7)	tBLR	15			ns
SDTI Hold Time from IBICK “↑”	tSDH	15			ns
SDTI Setup Time to IBICK “↑”	tSDS	15			ns
Input PORT (Master mode)					
IBICK Frequency	fBCK		64fs		Hz
IBICK Duty	dBCK		50		%
IBICK “↓” to ILRCK	tMBLR	-20		20	ns
SDTI Hold Time from IBICK “↑”	tSDH	15			ns
SDTI Setup Time to IBICK “↑”	tSDS	15			ns
Output PORT (Slave mode)					
OBICK Period (8kHz ~ 108kHz)	tBCK	1/128fs			ns
(108kHz ~ 216kHz)	tBCK	1/64fs			ns
OBICK Pulse Width Low	tBCKL	27			ns
Pulse Width High	tBCKH	27			ns
OLRCK Edge to OBICK “↑” (Note 7)	tLRB	20			ns
OBICK “↑” to OLRCK Edge (Note 7)	tBLR	20			ns
OLRCK to SDTO (MSB) (Except I ² S mode)	tLRS			20	ns
OBICK “↓” to SDTO	tBSD			20	ns
Output PORT (Master mode)					
OBICK Frequency	fBCK		64fs		Hz
OBICK Duty	dBCK		50		%
OBICK “↓” to OLRCK	tMBLR	-20		20	ns
OBICK “↓” to SDTO	tBSD	-20		20	ns
Reset Timing					
PDN Pulse Width (Note 8)	tPD	150			ns

Note 7. BICK rising edge must not occur at the same time as LRCK edge.

Note 8. The AK4125 can be reset by bringing the PDN pin = “L”.

■ Timing Diagram

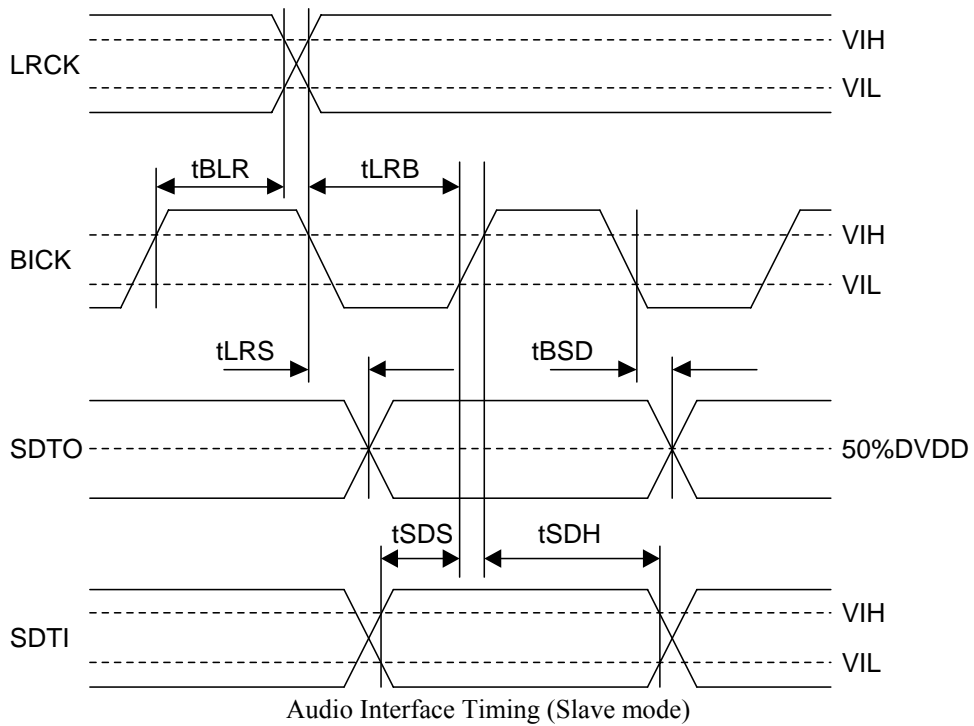
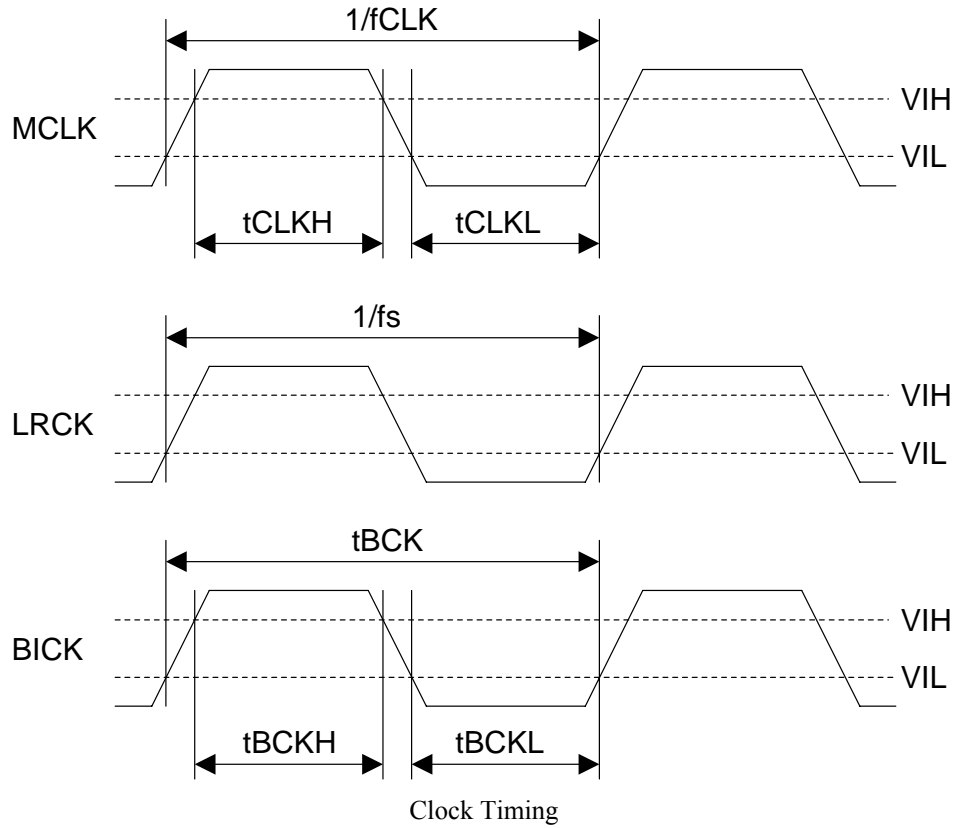

Note: BICK shows IBICK and OBICK, LRCK shows ILRCK and OLRCK.

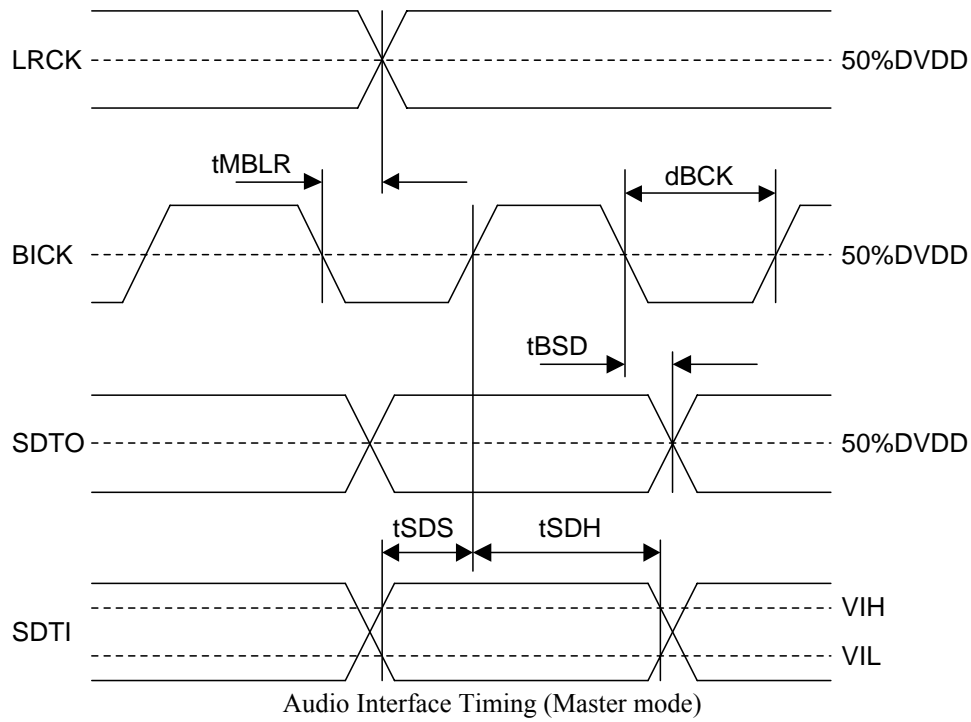

Note: BICK shows IBICK and OBICK, LRCK shows ILRCK and OLRCK.

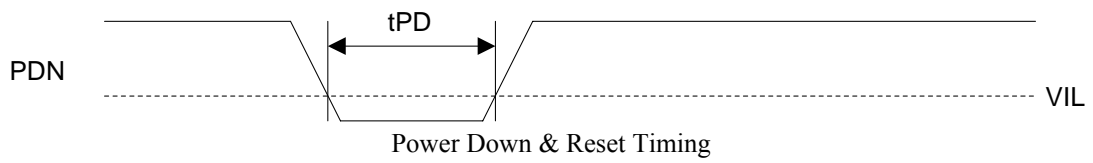

OPERATION OVERVIEW

■ System Clock & Audio Interface Format for Input PORT

The input port works in master mode or slave mode. An internal system clock is created by the internal PLL using ILRCK (Mode 0 ~ 2 of Table 2) or IBICK (Mode 4 ~ 7 of Table 2) in slave mode. The MCLK is not needed in slave mode. And an internal system clock is created by IMCLK (Mode 8 ~ 15 of Table 2) in master mode. The PLL2-0 pins and IDIF2-0 pins select the master/slave and PLL mode. The PLL2-0 pins and IDIF2-0 pins should be controlled when the PDN pin = "L".

The IDIF2-0 pins select the audio interface format for the input port. The audio data is MSB first, 2's compliment format. The SDTI is latched on the rising edge of IBICK. Select the audio interface format when the PDN pin = "L". When in BYPASS mode, both IBICK and OBICK are fixed to 64fs.

Mode	IDIF2	IDIF1	IDIF0	SDTI Format	ILRCK	IBICK	IBICK Freq	Master / Slave
0	L	L	L	16bit, LSB justified	Input	Input	≥ 32fsi	Slave
1	L	L	H	20bit, LSB justified			≥ 40fsi	
2	L	H	L	24/20bit, MSB justified			≥ 48fsi	
3	L	H	H	24/16bit, I ² S Compatible			≥ 48fsi or 32fsi	
4	H	L	L	24bit, LSB justified			≥ 48fsi	
5	H	L	H	24bit, MSB justified	Output	Output	64fs	Master
6	H	H	L	24bit, I ² S Compatible			64fs	
7	H	H	H	Reserved				

Table 1. Input Audio Interface Format (Input PORT)

Mode	Master / Slave	PLL2	PLL1	PLL0	ILRCK Freq	IBICK Freq	IMCLK	SMUTE (Note 13)	
0	Slave IMCLK = DVSS IBICK = Input ILRCK = Input	L	L	L	8k ~ 96kHz	Depending on IDIF2-0 (Note 10)	Not needed. (Note 12)	Manual	
1		L	L	H	8k ~ 216kHz				
2		L	H	L	16k ~ 216kHz (Note 9)				
3		Master IMCLK = Input IBICK = Output ILRCK = Output	L	H	H	Reserved			Manual
4			H	L	L	8k ~ 216kHz (Note 10)	32fsi (Note 11)	Not needed. (Note 12)	
5			H	L	H		64fsi		
6			H	H	L		128fsi		
7	H	H	H	64fsi					
8	Master IMCLK = Input IBICK = Output ILRCK = Output	L	L	L	8k ~ 216kHz	64fs	128fs	Manual	
9		L	L	H	8k ~ 108kHz		256fs		
10		L	H	L	8k ~ 54kHz		512fs	Semi-Auto	
11		L	H	H	8k ~ 216kHz		128fs		
12		H	L	L	8k ~ 216kHz		192fs	Manual	
13		H	L	H	8k ~ 108kHz		384fs		
14		H	H	L	8k ~ 54kHz		768fs	Semi-Auto	
15		H	H	H	8k ~ 216kHz		192fs		

Table 2. PLL Setting (Input PORT)

Note 9. PLL lock rage is changed by the value of R and C connected FILT pin. Refer to "PLL Loop Filter".

Note 10. IBCIK must be continuous except when the clocks are changed.

Note 11. IBCIK = 32fsi is supported only 16bit LSB justified and I²S Compatible.

Note 12. Fixed to DVSS.

Note 13. Refer to "Soft Mute Operation" for Manual mode and Semi-Auto mode.

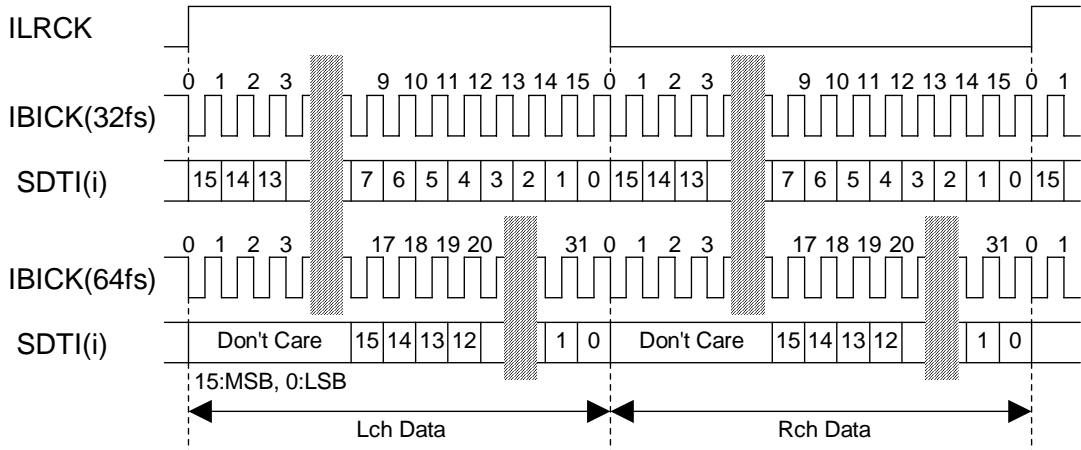

Figure 1. Mode 0 Timing

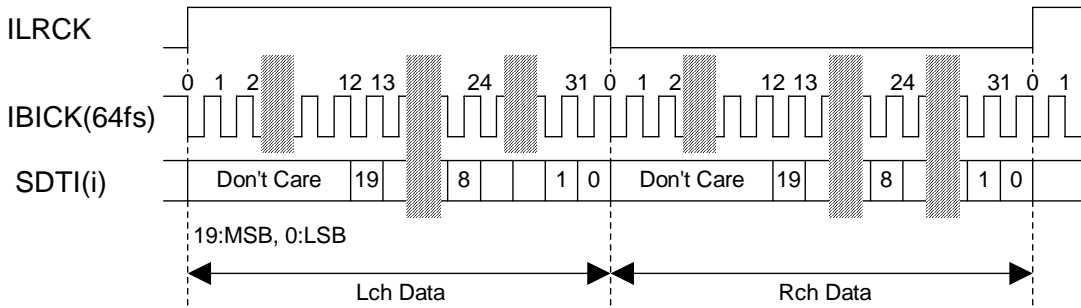

Figure 2. Mode 1 Timing

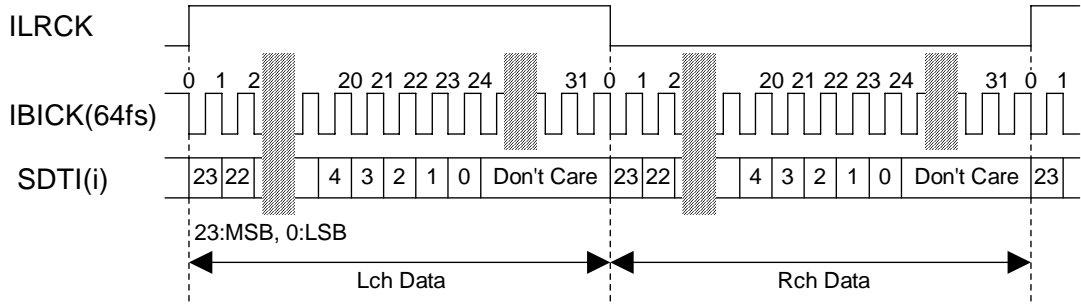

Figure 3. Mode 2, 5 Timing (24bit MSB)

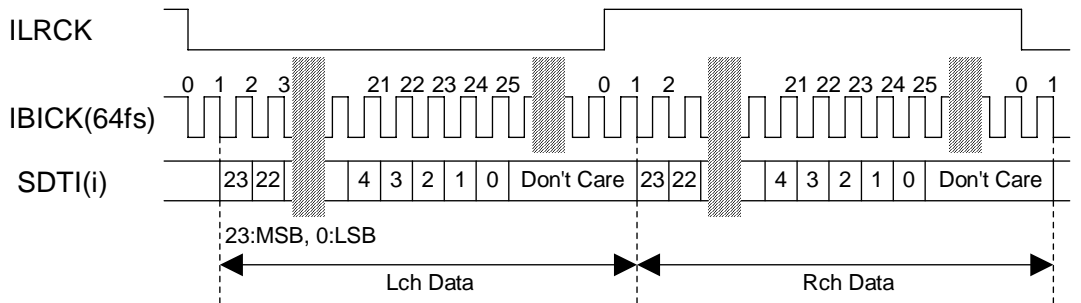

Figure 4. Mode 3, 6 Timing (24bit I²S)

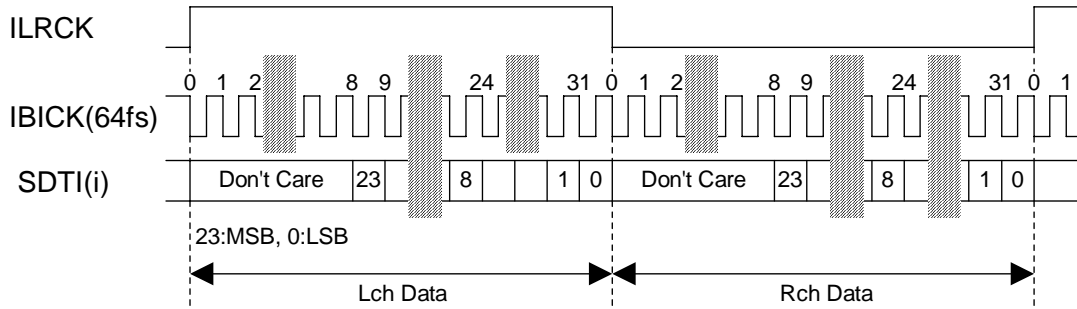

Figure 5. Mode 4 Timing

■ System Clock & Audio Interface Format for Output PORT

The output port works in master mode or slave mode. The MCLK is not needed in slave mode. The CMODE2-0 pins select the master/slave and bypass mode. The CMODE2-0 pins should be controlled when the PDN pin = “L”.

The ODIF1-0 pins and OBIT1-0 pins select the audio interface format for the output port. The audio data is MSB first, 2’s compliment format. The SDTO is clocked out on the falling edge of OBICK. Select the audio interface format when the PDN pin = “L”. When in BYPASS mode, both IBICK and OBICK are fixed to 64fs.

Mode	CMODE 2	CMODE 1	CMODE0	Master / Slave	OMCLK	fso
0	L	L	L	Master	256fso	8k ~ 108kHz
1	L	L	H	Master	384fso	8k ~ 108kHz
2	L	H	L	Master	512fso	8k ~ 54kHz
3	L	H	H	Master	768fso	8k ~ 54kHz
4	H	L	L	Slave	Not used. Set to DVSS.	8k ~ 216kHz
5	H	L	H	Master	128fso	8k ~ 216kHz
6	H	H	L	Master	192fso	8k ~ 216kHz
7	H	H	H	Master (Bypass)	Not used. Set to DVSS.	8k ~ 216kHz

Table 3. Master/Slave Control (Output PORT)

Mode	ODIF1	ODIF0	SDTO Format
0	L	L	LSB justified
1	L	H	(Reserved)
2	H	L	MSB justified
3	H	H	I ² S Compatible

Table 4. Output Audio Interface Format 1 (Output PORT)

Mode	Master / Slave	OBIT1	OBIT0	SDTO	OLRCK	OBICK	OBICK Frequency	
							MSB justified, I ² S	LSB justified
0	Slave CMODE2-0 = “HLL”	L	L	16bit	Input	Input	≥ 32fso	64fso
1		L	H	18bit			≥ 36fso	
2		H	L	20bit			≥ 40fso	
3		H	H	24bit			≥ 48fso	
4	Master Except CMODE2-0 = “HLL”	L	L	16bit	Output	Output	64fso	
5		L	H	18bit				
6		H	L	20bit				
7		H	H	24bit				

Table 5. Output Audio Interface Format 2 (Output PORT)

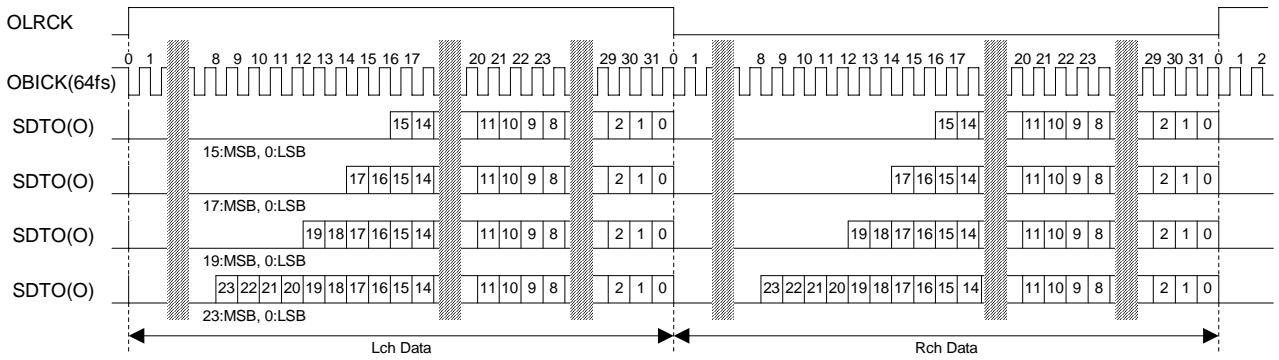

Figure 6. LSB Timing

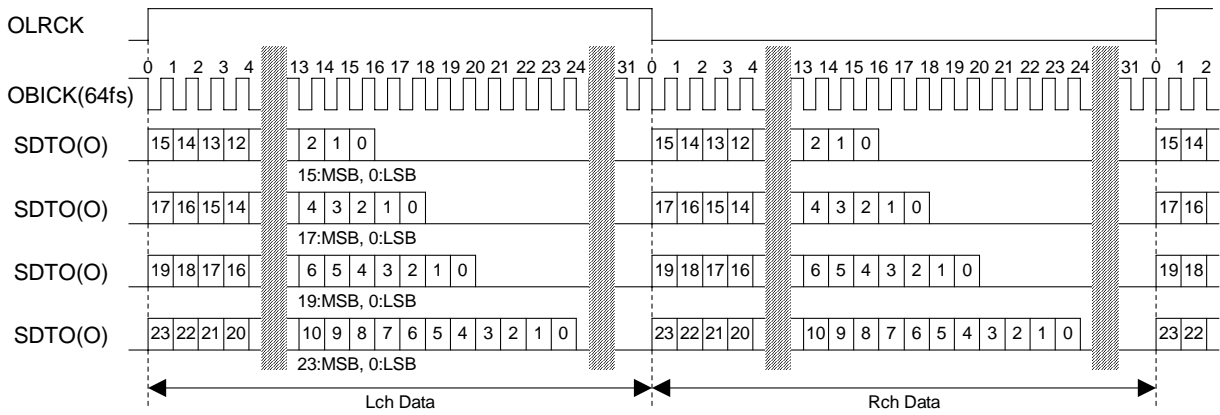

Figure 7. MSB Timing

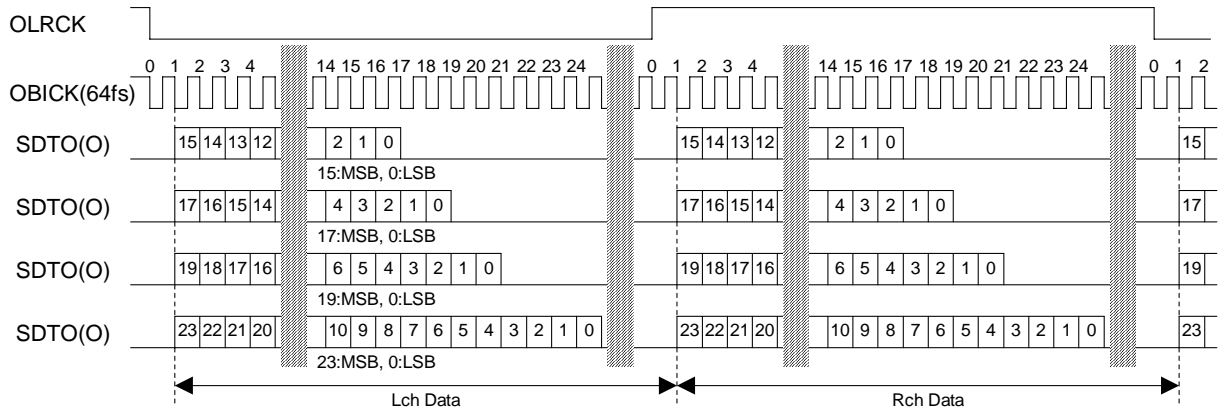

Figure 8. I²S Compatible Timing

■ Soft Mute Operation

1. Manual mode

Soft mute operation is performed in the digital domain of the SRC output. Soft mute can be controlled by the SMUTE pin. When the SMUTE pin changes to “H”, the SRC output data is attenuated by $-\infty$ within 1024 OLRCK cycles. When the SMUTE pin changes to “L”, the mute is cancelled and the output attenuation gradually changes to 0dB during 1024 OLRCK cycles. If the soft mute is cancelled before mute state after starting the operation, the attenuation is discontinued and returned to 0dB by the same cycles. The soft mute is effective for changing the signal source.

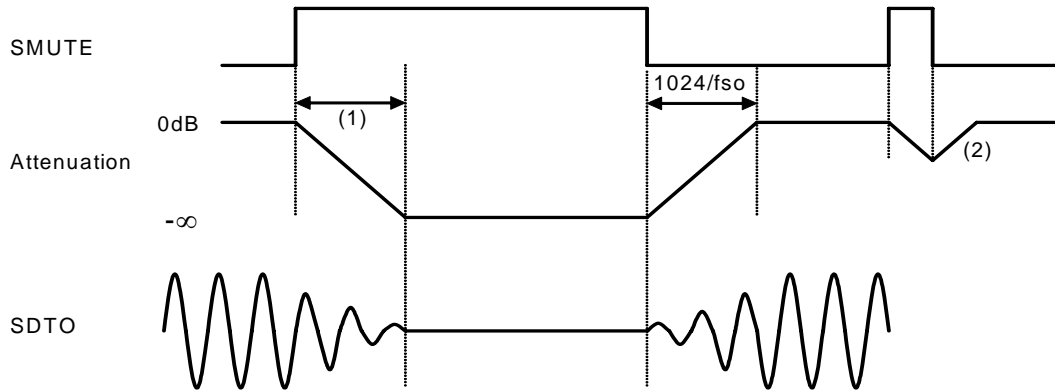

Figure 9. Soft Mute Function (Manual Mode)

- (1) The output data is attenuated by $-\infty$ during 1024 OLRCK cycles ($1024/f_{so}$).
- (2) If the soft mute is cancelled before attenuating to $-\infty$ after starting the operation, the attenuation is discontinued and returned to 0dB by the same number of clock cycles.

2. Semi-Auto mode

The soft mute is cancelled automatically by the setting of PLL2-0 pins (Table 2), after the AK4125 detects the rising edge (PDN pin = “L” → “H”) and the mute is continued during $4410/f_{so}=100ms@f_{so}=44.1kHz$. After PDN pin = “L” → “H” and when the SMUTE pin is “H”, the mute is not cancelled.

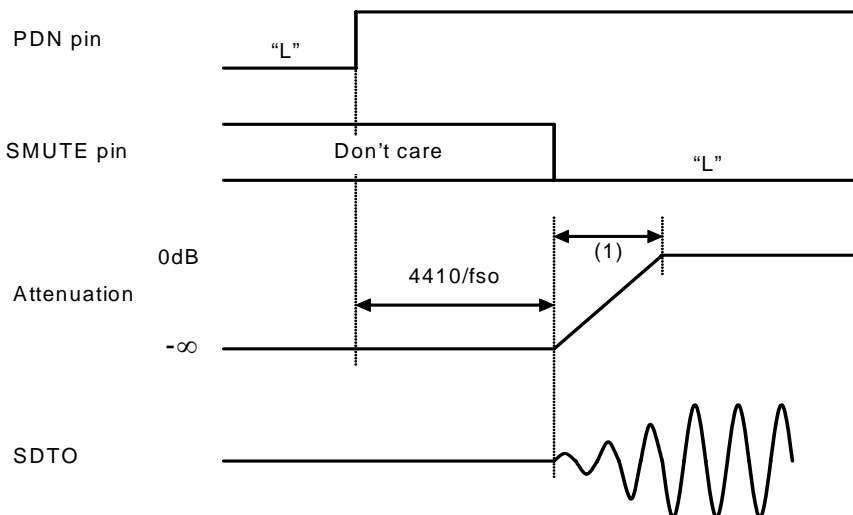

Figure 10. Soft Mute Function (Semi-Auto Mode)

- (1) The output data is returned to 0dB during 1024 OLRCK cycles ($1024/f_{so}$).

■ Dither

The AK4125 has a dither circuit. The dither circuit adds the dither to the LSB of the output data, which is the value of the OBIT1-0 pins, by DITHER pin = “H” regardless of the SRC mode or the SRC bypass mode.

■ System Reset

Bringing the PDN pin = “L” sets the AK4125 power-down mode and initializes the digital filter. The AK4125 should be reset once by bringing the PDN pin = “L” when power-up. When the PDN pin = “L”, the SDTO output is “L”. The SDTO valid time is 100ms. Until the output data becomes valid, the SDTO pin outputs “L”.

Case 1

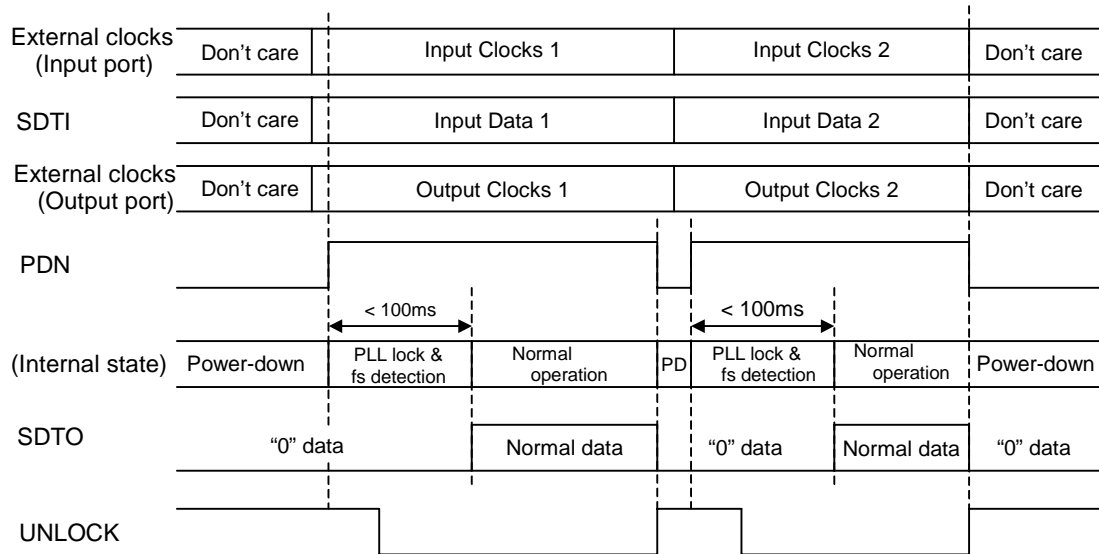

Figure 11. System Reset

Case 2

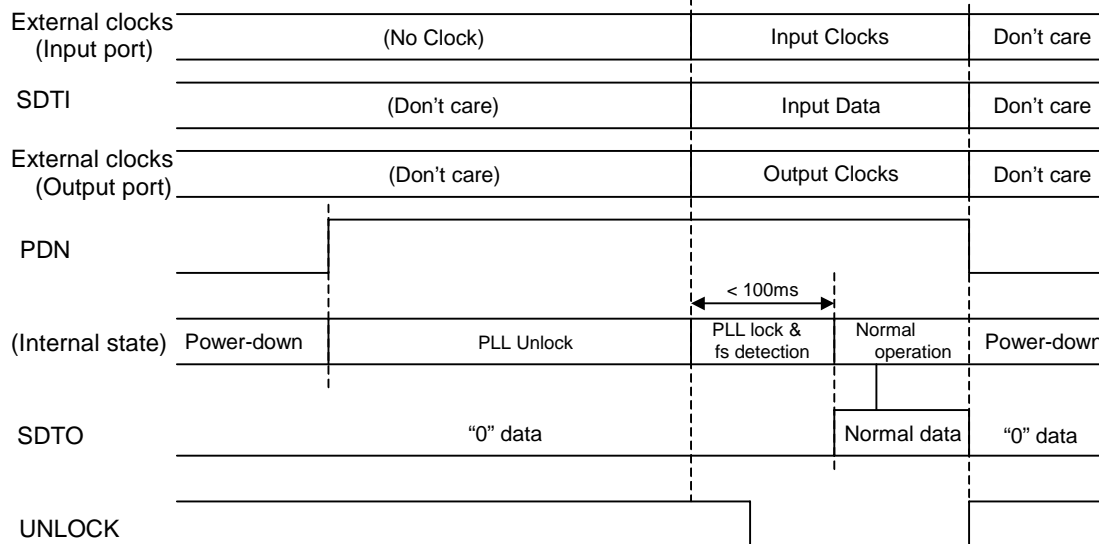

Figure 12. System Reset 2

■ Internal Reset Function for Clock Change

The AK4125 is reset automatically when the output clock is stopped. If the output clock is started again, normal data is output within 100ms.

■ Sequence of Changing Clocks

The change of the clock supplied to AK4125 is shown in Figure 13.

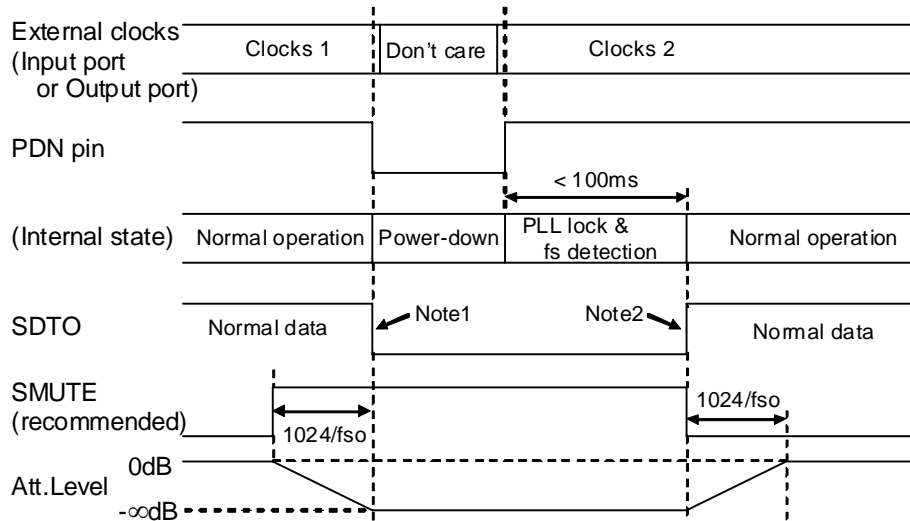

Figure 13. Sequence of Changing Clocks

Note 1. The data on SDTO may cause a clicking noise. To prevent this, set "0" to the SDTI from GD before the PDN pin changes to "L". It makes the data on SDTO remain as "0". SMUTE can also remove this clicking noise.

Note 2. The data on SDTO may cause a clicking noise. To prevent this, set SDTI to "0" for $1024/f_{so} + 100\text{ms}$ or more from the timing PDN pin changes to "H" while the SMUTE pin = "H".

Note 3. When the PDN pin is not used for this clock change, a distorted signal may output for about 10ms ~ 100ms (typ) after changing clocks.

■ UNLOCK pin

The UNLOCK pin outputs "L" when the internal PLL is locked. When the internal PLL is unlocked, the UNLOCK pin outputs "H" and the SDTO = "0". When the PDN pin = "L", the UNLOCK pin outputs "H".

■ PLL Loop Filter

The C1 and R should be connected in series and attached between FILT pin and AVSS in parallel with C2. (Figure 14, Table 6, Table 7) Please be careful the noise onto the FILT pin. When using IBICK, the value of external element is not dependent on the IBICK input frequency.

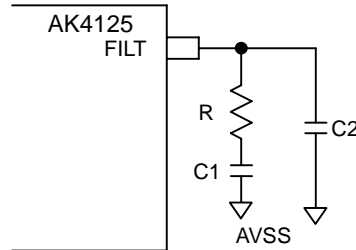

Figure 14. PLL Loop Filter

[Input PORT in slave mode]

1. When using ILRCK

PLL2	PLL1	PLL0	ILRCK	R [Ω]	C1 [μ F]	C2 [nF]
L	L	L	8k ~ 96kHz	$1.8k \pm 5\%$	$0.68 \pm 30\%$	$0.68 \pm 30\%$
L	L	H	8k ~ 216kHz	$1k \pm 5\%$	$1.0 \pm 30\%$	$2.2 \pm 30\%$
			16k ~ 216kHz	$1.5k \pm 5\%$	$0.68 \pm 30\%$	$0.68 \pm 30\%$
L	H	L	8k ~ 216kHz	$1k \pm 5\%$	$1.0 \pm 30\%$	$2.2 \pm 30\%$
			16k ~ 216kHz	$1.5k \pm 5\%$	$0.68 \pm 30\%$	$0.68 \pm 30\%$

Table 6. PLL Loop Filter (ILRCK Mode)

- Note. Smaller value can be selected for the capacitors (C1, C2) in case of ILRCK range from 16kHz to 216kHz..

2. When using IBICK

PLL2	PLL1	PLL0	ILRCK	R [Ω]	C1 [μ F]	C2 [nF]
H	*	*	8k ~ 216kHz	$470 \pm 5\%$	$0.22 \pm 30\%$	$1.0 \pm 30\%$

Table 7. PLL Loop Filter (IBICK Mode, *: Don't care)

Note. The IBCIK must be continuous except when the clocks are changed.

Note. IBCIK = 32fsi is supported only 16bit LSB justified and I²S Compatible.

[Input PORT in master mode]

- When IMCLK is 256fs, 384fs, 512fs or 768fs, any external parts shown in Figure 14 are not required.
- When IMCLK is 128fs or 192fs, the external parts shown in Table 7 are required.

SYSTEM DESIGN

Figure 15, Figure 16 show the system connection diagram. The evaluation board demonstrates application circuits, the optimum layout, power supply arrangements and measurement results.

- Input PORT: Slave Mode, IBICK lock mode (64fsi), 24bit MSB justified
- Output PORT: Slave mode, 24bit MSB justified
- Dither = OFF

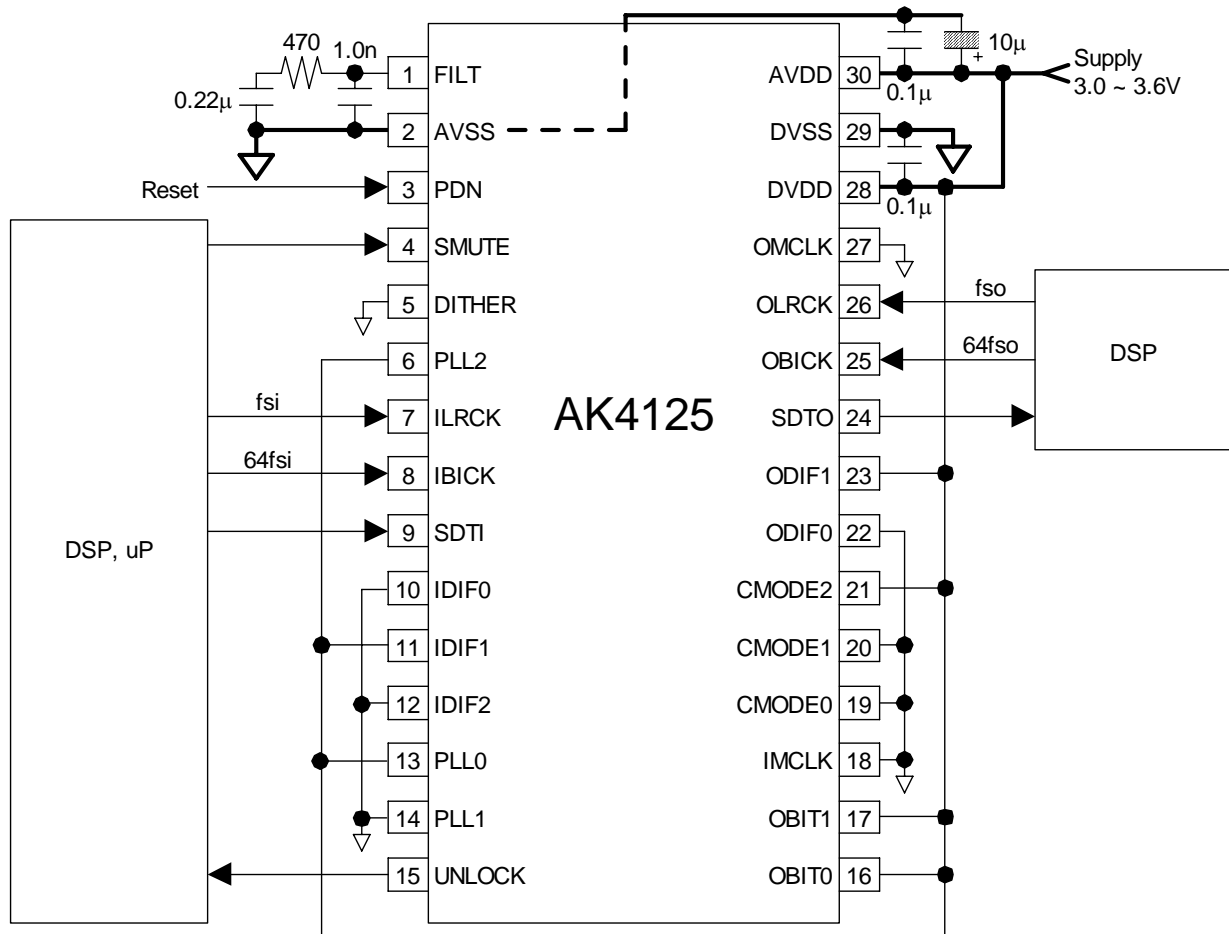

Note:

- AVSS and DVSS of the AK4125 should be distributed separately from the ground of external digital devices (MPU, DSP etc.).
- All digital input pins should not be left floating.

Figure 15. Typical Connection Diagram (Slave mode)

- Input PORT: Slave Mode, IBICK lock mode (64fsi), 24bit MSB justified
- Output PORT: Master mode, 24bit MSB justified
- Dither = OFF

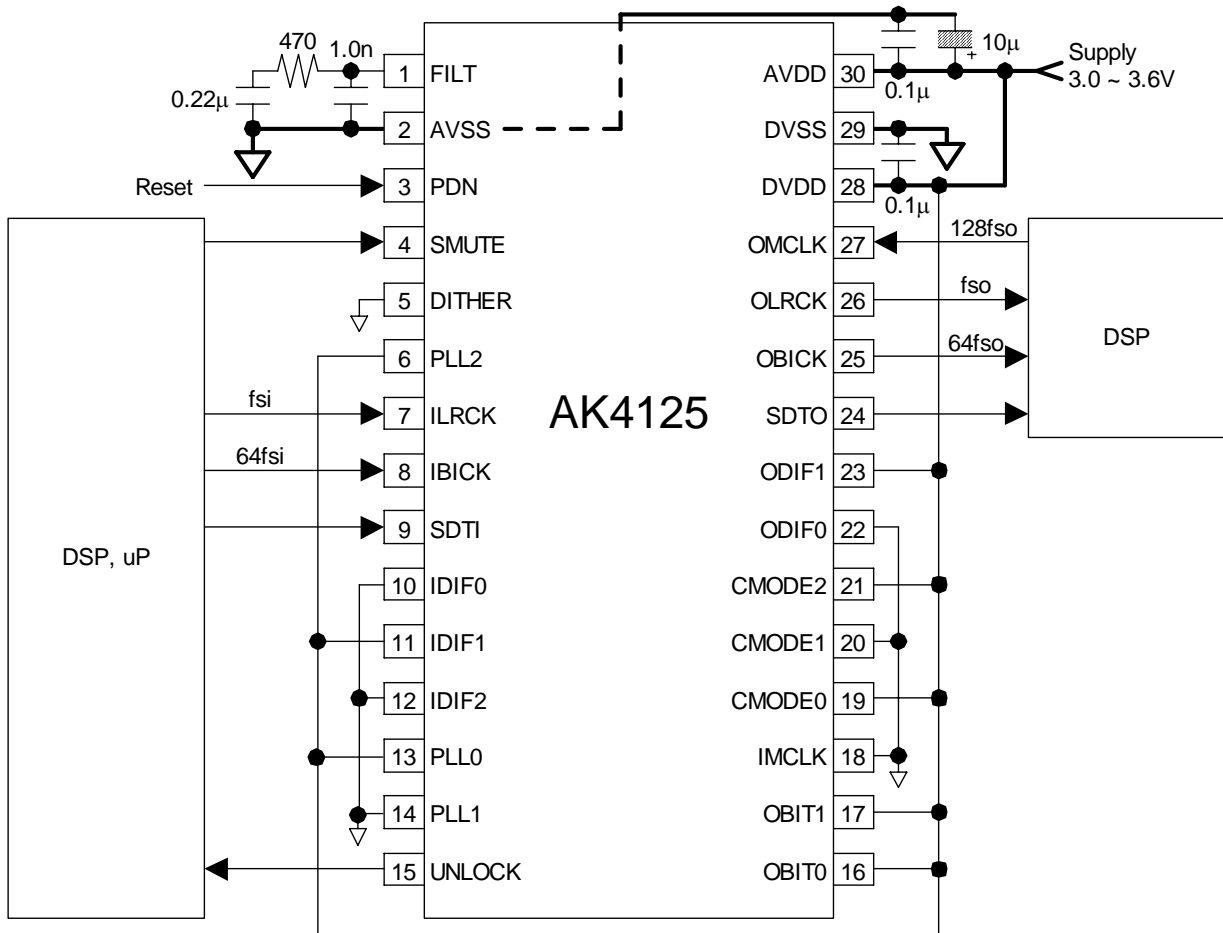

Note:

- AVSS and DVSS of the AK4125 should be distributed separately from the ground of external digital devices (MPU, DSP etc.).
- All digital input pins should not be left floating.

Figure 16. Typical Connection Diagram (Master mode)

1. Grounding and Power Supply Decoupling

The AK4125 requires careful attention to power supply and grounding arrangements. Alternatively if AVDD and DVDD are supplied separately, the power up sequence is not important. Decoupling capacitors should be as near to the AK4125 as possible, with the small value ceramic capacitor being the nearest.

2. Jitter Tolerance

Figure 17 shows the jitter tolerance to ILRCK and IBICK. The jitter quantity is defined by the jitter frequency and the jitter amplitude shown in Figure 17. When the jitter amplitude is 0.01UIpp or less, the AK4125 operates normally regardless of the jitter frequency.

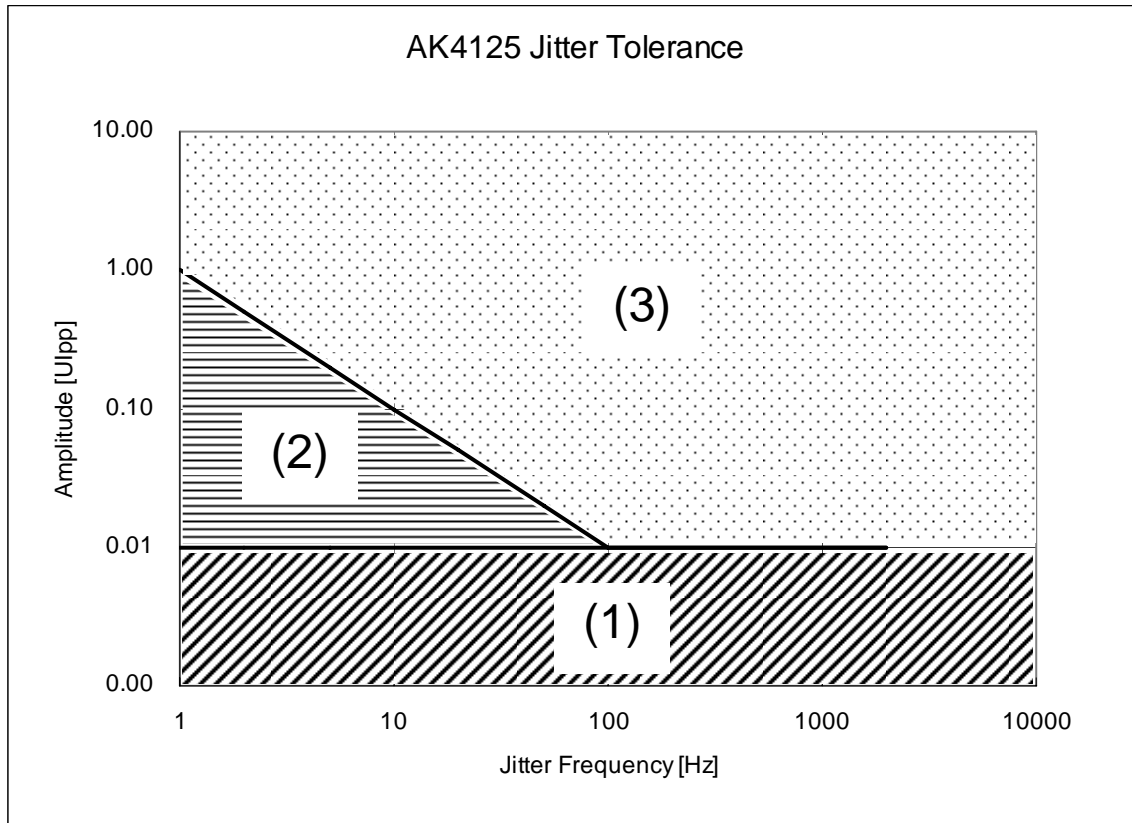

- (1) Normal operation
- (2) There is a possibility that the distortion degrades. (It may degrade up to about -50dB .)
- (3) There is a possibility that the output data is lost.

Note:

- When PLL2-0 = "L/L/L", "L/L/H", "L/H/L", the jitter amplitude is for ILRCK and 1UI (Unit Interval) is one cycle of ILRCK. When FSI = 48kHz, 1UI is $1/48\text{kHz} = 20.8\mu\text{s}$.
- When PLL2-0 = "H/*/*" (*: Don't care), the jitter amplitude is for IBICK and 1UI (Unit Interval) is one cycle of IBICK. When FSI = 48kHz, 1UI is $1/(64 \times 48\text{kHz}) = 326\text{ns}$.

Figure 17. Jitter Tolerance

Tracking to the Input Sampling Frequency

When the ILRCK is generated by an external PLL, it may take time to settle after changing the input sampling frequency because the response of an external PLL to the frequency change is slow. The AK4125 operates normally up to 23%/sec speed but outputs incorrect data at the speed of the frequency change over 23%/sec.

3. Digital Filter Response Example

Table 8 shows the examples of digital filter response performed by the AK4125.

Ratio	FSO/FSI [kHz]	Passband [kHz]	Stopband [kHz]	Stopband Attenuation [dB]	Gain [dB]
4.000	192/48.0	22.000	26.000	-121.2	-0.01@ 20k
1.000	48.0/48.0	22.000	26.000	-121.2	-0.01@ 20k
0.919	44.1/48.0	20.000	24.100	-121.4	-0.01@ 20k
0.725	32.0/44.1	14.088	17.487	-115.3	-0.01@ 14.5k
0.667	32.0/48.0	13.688	17.488	-116.9	-0.19@ 14.5k
0.544	48.0/88.2	19.250	26.232	-114.6	-0.03@ 20k
0.500	48.0/96.0	20.900	27.000	-100.2	-0.01@ 20k
0.500	44.1/88.2	19.202	24.806	-100.2	-0.08@ 20k
0.459	44.1/96.0	18.700	25.000	-103.3	-0.23@ 20k
0.363	32.0/88.2	12.863	18.665	-102.0	-0.75@ 14.5k
0.333	32.0/96.0	12.500	18.900	-103.6	-1.07@ 14.5k
0.250	48.0/192.0	17.600	30.200	-104.0	-0.18@ 20k
0.250	44.1/176.4	16.170	27.746	-104.0	-1.34@ 20k
0.230	44.1/192.0	15.860	28.240	-103.3	-1.40@ 20k
0.167	32.0/192.0	11.200	19.600	-73.2	-2.97@ 14.5k
0.181	32.0/176.4	10.278	17.987	-73.2	-7.88@ 14.5k
0.167	8/48.0	2.800	4.900	-73.2	-2.97@ 3.625k
0.181	8/44.1	2.5695	4.4968	-73.2	-7.88@ 3.625k

Table 8. Digital Filter Example

PACKAGE

30pin VSOP (Unit: mm)

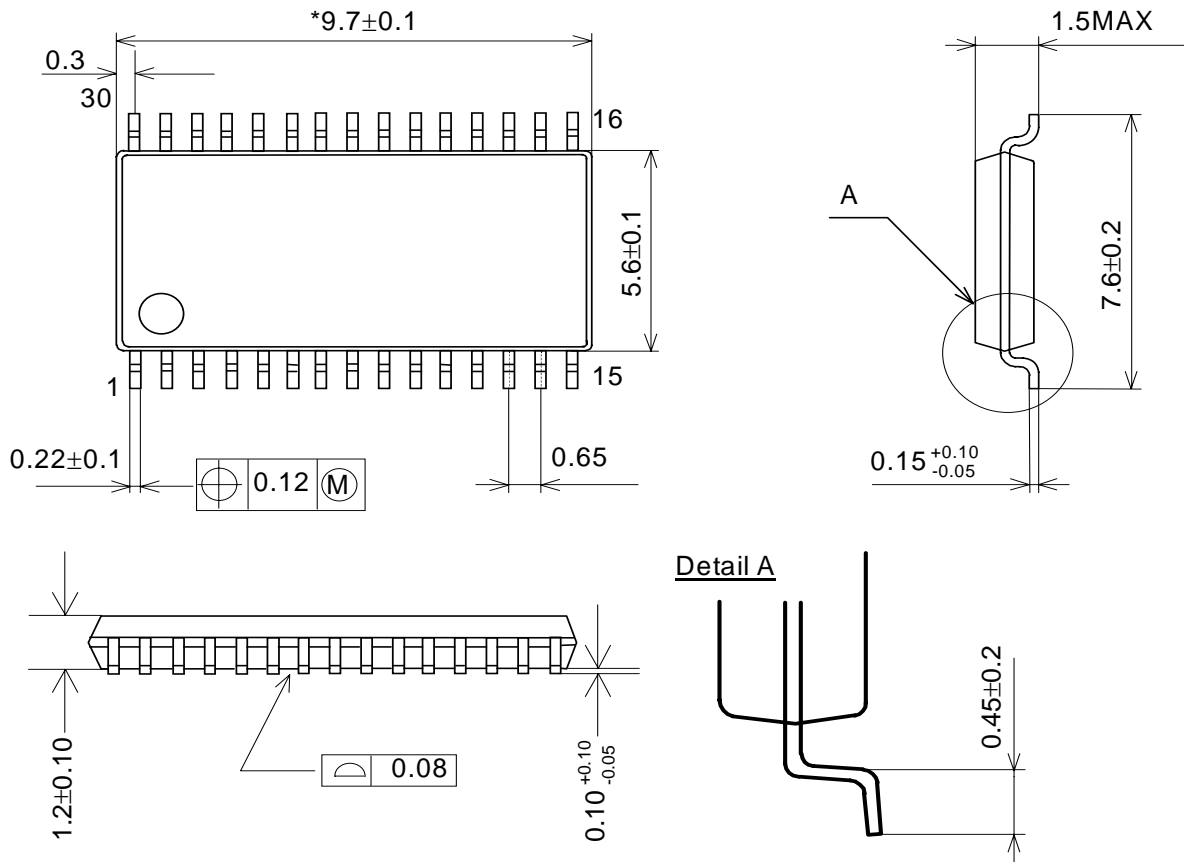

NOTE: Dimension "*" does not include mold flash.

■ Material & Lead finish

- Package molding compound: Epoxy
- Lead frame material: Cu
- Lead frame surface treatment: Solder (Pb free) plate

MARKING

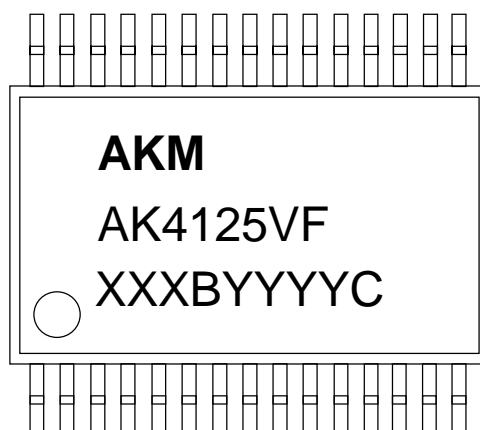

XXXBYYYYC Date code identifier

XXXB: Lot number (X: Digit number, B: Alpha character)
 YYYYYC: Assembly date (Y: Digit number, C: Alpha character)

REVISION HISTORY

Date (YY/MM/DD)	Revision	Reason	Page	Contents
05/01/05	00	First Edition		
05/05/10	01	Comment Addition	22	A note on IBICK was added.
06/06/20	02	Error Correction	6	THD+N Worst Case condition FSO/FSI = 48kHz/8kHz → 32kHz/176.4kHz
07/02/20	03	Error Correction	9	Switching Characteristics (ILRCK) Master/Slave modes were added to Duty Cycle.
			20,21	Connections of PLL1/PLL0 pins were corrected.
07/07/25	04	Description Change	16	Figure 9 and Figure 10 were changed.
			18	<ul style="list-style-type: none"> ■ Internal Rest Function for Clock Change ■ Sequence of Changing Clocks ■ UNLOCK pin
10/05/17	05	Description Addition	18	<ul style="list-style-type: none"> ■ Sequence of changing clocks Description is added in notes.

IMPORTANT NOTICE

- These products and their specifications are subject to change without notice.
When you consider any use or application of these products, please make inquiries the sales office of Asahi Kasei Microdevices Corporation (AKM) or authorized distributors as to current status of the products.
- Descriptions of external circuits, application circuits, software and other related information contained in this document are provided only to illustrate the operation and application examples of the semiconductor products. You are fully responsible for the incorporation of these external circuits, application circuits, software and other related information in the design of your equipments. AKM assumes no responsibility for any losses incurred by you or third parties arising from the use of these information herein. AKM assumes no liability for infringement of any patent, intellectual property, or other rights in the application or use of such information contained herein.
- Any export of these products, or devices or systems containing them, may require an export license or other official approval under the law and regulations of the country of export pertaining to customs and tariffs, currency exchange, or strategic materials.
- AKM products are neither intended nor authorized for use as critical components^{Note1)} in any safety, life support, or other hazard related device or system^{Note2)}, and AKM assumes no responsibility for such use, except for the use approved with the express written consent by Representative Director of AKM. As used here:
 - Note1) A critical component is one whose failure to function or perform may reasonably be expected to result, whether directly or indirectly, in the loss of the safety or effectiveness of the device or system containing it, and which must therefore meet very high standards of performance and reliability.
 - Note2) A hazard related device or system is one designed or intended for life support or maintenance of safety or for applications in medicine, aerospace, nuclear energy, or other fields, in which its failure to function or perform may reasonably be expected to result in loss of life or in significant injury or damage to person or property.
- It is the responsibility of the buyer or distributor of AKM products, who distributes, disposes of, or otherwise places the product with a third party, to notify such third party in advance of the above content and conditions, and the buyer or distributor agrees to assume any and all responsibility and liability for and hold AKM harmless from any and all claims arising from the use of said product in the absence of such notification.