

AsahiKASEI
ASAHI KASEI EMD

AKD4145-A
Evaluation board Rev.3 for AK4145

GENERAL DESCRIPTION

The AKD4145 is an evaluation board for the AK4145, BTSC Encoder with D/A Converter, which is optimized for Digital AV application. The AKD4145 has the analog/digital audio interface and can achieve the interface with analog/digital audio systems via BNC/OPT-connector.

■ **Ordering guide**

AKD4145-A --- Evaluation board for AK4145
(Cable for connecting with printer port of IBM-AT, compatible PC and control software are packed with this. This control software does not support Windows NT.)

FUNCTION

- **ADC with analog input**
- **DIR with optical input**
- **10pin Header for digital audio I/F and serial control I/F**

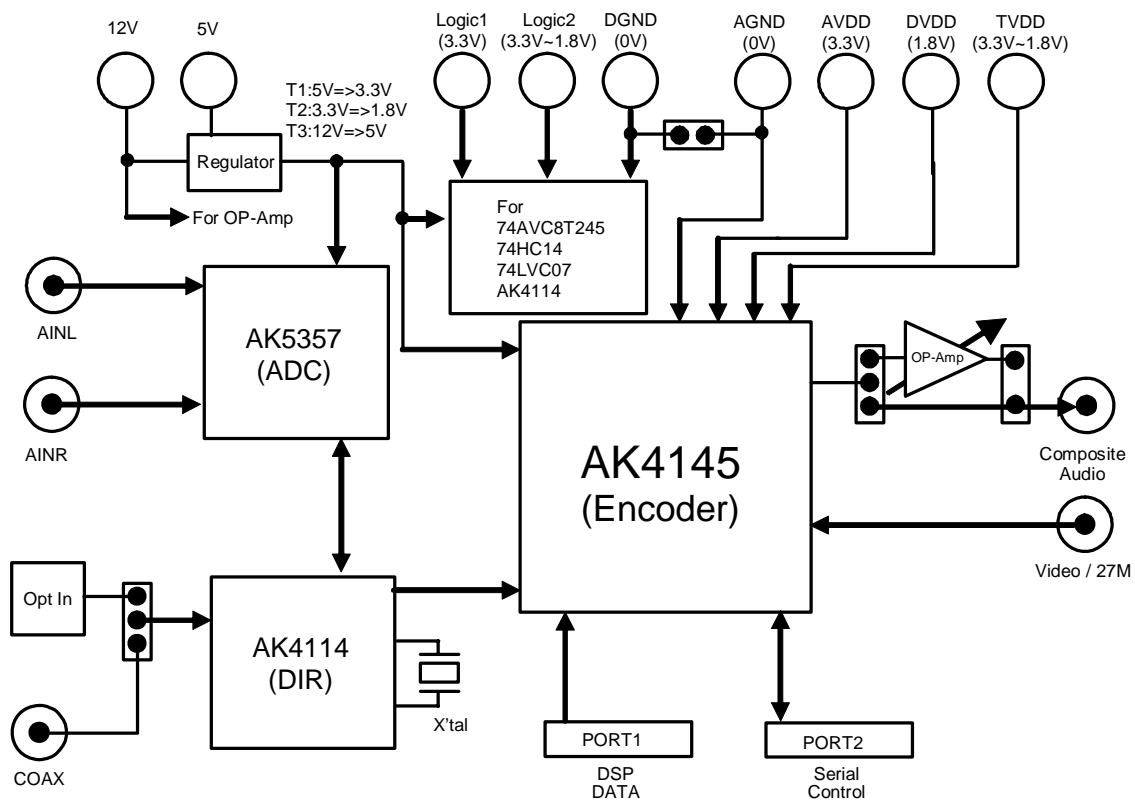

Figure. 1 AKD4145 Block Diagram

* Circuit diagram and PCB layout are attached at the end of this manual

Evaluation Board Manual

■ Operation sequence

1) Set up the power supply lines.

(1-1) In case of using the regulator.<Default>

Set up the jumper pins.

JP	JP13	JP14	JP15	JP17	JP18	JP22	JP23
		AVDD-SEL	DVDD-SEL	TVDD-SEL	Logic2-SEL	Logic1-SEL	5V-REG
State	REG(3.3V)	REG(1.8V)	REG(3.3V)	TVDD	REG(3.3V)	Short	REG(3.3V)

Set up the power supply lines.

[REG(12V)] (red) = +12V : for regulator and OP-Amp
 [REG(5V)] (red) = open : “5V” is supplied from Regulator (T3)
 [AVDD] (orange) = open : “3.3V” is supplied from Regulator (T1)
 [DVDD] (orange) = open : “1.8V” is supplied from Regulator (T2)
 [TVDD] (orange) = open : “3.3V” is supplied from Regulator (T1)
 [Logic1] (orange) = open : “3.3V” is supplied from Regulator (T1)
 [Logic2] (orange) = open : “3.3V” is supplied from Regulator (T1)
 [AGND] (black) = 0V : analog ground
 [DGND] (black) = 0V : digital ground
 (Note) VA and VD of AK5357 (ADC) is supplied “3.3V” from regulator (T1).

(1-2) In case of using the power supply connectors.

Set up the jumper pins.

JP	JP13	JP14	JP15	JP17	JP18	JP22	JP23
		AVDD-SEL	DVDD-SEL	TVDD-SEL	Logic2-SEL	Logic1-SEL	5V-REG
State	TM	TM	TM	TM	TM	Open	TM

Set up the power supply lines.

[REG(12V)] (red) = +12V : for OP-Amp
 [REG(5V)] (red) = +5V : for regulator (T1, T2)
 [AVDD] (orange) = +2.7~3.6V : for AVDD of AK4145 (typ. 3.3V)
 [DVDD] (orange) = +1.7~1.9V : for DVDD of AK4145 (typ. 1.8V)
 [TVDD] (orange) = +1.7~3.6V : for TVDD of AK4145 (typ. 3.3V)
 [Logic1] (orange) = +2.7~3.6V : for logic (typ. 3.3V)
 [Logic2] (orange) = +1.7~3.6V : for logic of I/F (typ. 3.3V : the voltage same as TVDD)
 [AGND] (black) = 0V : analog ground
 [DGND] (black) = 0V : digital ground
 (Note) VA and VD of AK5357 (ADC) is supplied “3.3V” from regulator (T1).

2) Set up the jumper pins and switches. (See the followings.)

3) Power on.

SW1 (AK4145), SW2 (ADC) and SW3 (DIR) should be reset once bringing toggle SW “L” upon power-up. Please refer to Table.1 on page.3 about setting of toggle SW.

■ Setting of the toggle SW

No.	Name	Function
SW1	PDN-AK4145	PDN SW of AK4145 (U2). Keep “H” during normal operation.
SW2	PDN-ADC	PDN SW of AK5357 (U1). Keep “H” during normal operation. Keep “L” when AK5357 is not used.
SW3	PDN-DIR	PDN SW of AK4114 (U4). Keep “H” during normal operation. Keep “L” when AK4114 is not used.

Table. 1 Setting of the toggle SW

■ Indication for LED

[LED1] (INT) : Monitor INT0 pin of the DIR (AK4114). LED turns on when PLL of the AK4114 is unlocked.

■ Setting of jumper pins

No	Name	Function
1	Serial	AK4145 Control Mode Open : Parallel Control. <Default> Short : Serial Control.
2	AMP	Output of OP-Amp Open : Out of use. Short : Connected. <Default>
3	CA	Output of CA THR : Out of use. AMP : Amplify CA with OP-Amp <Default>
4	I2S	Audio I/F of AK5357 (ADC) Open : 24bit MSB justified. Short : 24bit I ² S Compatible. <Default>
6	RX	RX input of AK4114 (DIR) OPT : Optical (PORT1). <Default> BNC : BNC RX (J6).
7	DIF/SCL	Selection of AK4145’s DIF/SCL pin DIF: DIF in parallel mode. <Default> SCL:SCL in serial mode.
8	FS/SDA	Selection of AK4145’s FS/SDA pin FS: FS in parallel mode. <Default> SDA : SDA in serial mode.
9	DIR-SDTI	Input of AK4145’s SDTI Open : PORT2. SDTI : DIR. <Default>
10	DIR-LRCK	Input of AK4145’s LRCK Open : PORT2. Short : DIR. <Default>

11	DIR-BICK	Input of AK4145's BICK Open : PORT2. Short : DIR. <Default>
12	DIR-MCLK	Input of AK4145's MCLK Open : PORT2. Short : DIR. <Default>
13	AVDD-SEL	Power supply of AK4145's AVDD REG(3.3V) : AVDD is supplied from regulator (T1). <Default> TM : AVDD is supplied from "AVDD" connector.
14	DVDD-SEL	Power supply of AK4145's DVDD REG(1.8V) : DVDD is supplied from regulator (T2). <Default> TM : DVDD is supplied from "DVDD" connector.
15	TVDD-SEL	Power supply of AK4145's TVDD DVDD : TVDD is supplied from DVDD. <Default> REG(3.3V) : TVDD is supplied from regulator (T1). TM : TVDD is supplied from "TVDD" connector.
16	GND	Analog GND and Digital GND Open : Separated. Short : Common. <Default>
17	Logic2-SEL	Power supply of logic2 TVDD: Logic2 is supplied from TVDD. <Default> TM : Logic2 is supplied from "Logic2" connector.
18	Logic1-SEL	Power supply of logic1 REG(3.3V) : Logic1 is supplied from regulator (T1). <Default> TM : Logic1 is supplied from "Logic1" connector.
22	5V-REG	Power supply of regulator (T1) Open : It is supplied from "REG-5V" connector. Short : It is supplied from regulator (T3). <Default>
23	3.3V-REG	Power supply of regulator (T2) REG(3.3V) : It is supplied from regulator (T3). <Default> TM : It is supplied from "REG-5V" connector.

Table. 2 Setting of jumper pins

■ Evaluation mode

Control Mode

The supporting control mode is as follows.

1. Parallel Mode <Default>
2. Serial Mode

1. Parallel Mode <Default>

(1-1) Set up the jumper pins.



(1-2) Set up the DIP SW (S3).

S3	DIF (Audio I/F)	FS (Sampling Rate)
L	24bit MSB Justified	32kHz
H	16/24bit I ² S Compatible <Default>	48kHz <Default>

Table. 3 Setting of AK4145's Parallel Mode

2. Serial Mode

(2-1) Set up the jumper pins.



(2-2) Connect of the 10 wire flat cable.

The AK4145 can be controlled via the printer port (parallel port) of IBM-AT compatible PC. Connect PORT3 (CTRL) with PC by 10 wire flat cable packed with the AKD4145.

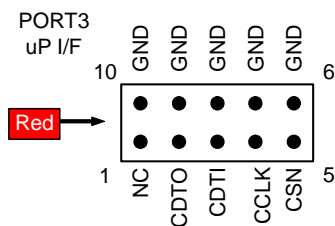

Figure. 2 Connect of 10 wire flat cable

Measurement Mode

The supporting measurement mode is as follows.

1. Evaluation using DIR of AK4114 <Default>
2. Evaluation using ADC of AK5357
3. All interface signals are fed externally

1. Evaluation using DIR of AK4114 <Default>

Measurement path :

Optical connector (PORT1) or BNC (J6) → DIR (AK4114) → AK4145

Please supply biphasic signal to Optical connector (PORT1) or BNC connector (J6). DIR generates MCLK, BICK, LRCK, and SDTI from received data.

(1-1) Set up the jumper pins.

JP6 (RX) should be set according to the RX input. Follow is setting example in Optical connector.

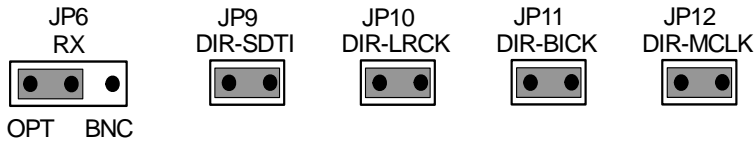

(1-2) Set up the DIP SW (S2).

In case of the AK4145 evaluation using the AK4114, it is necessary to correspond to the audio interface format for AK4145 (SDTI) and AK4114 (SDTO). About AK4145's audio interface format, refer to datasheet of AK4145. About AK4114's audio interface format, refer to Table. 6 on page 8.

(Note) AK4145's default setting of Audio interface format is I²S Compatible in parallel mode.

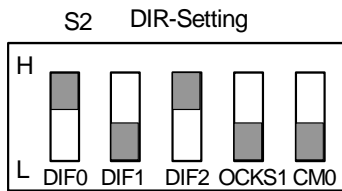

2. Evaluation using ADC of AK5357

Measurement path :

AINL(J3) / AINR (J2) → ADC (AK5357) → DIR (AK4114) → AK4145

Please supply analog signal to AINL (J3) / AINR (J2). DIR generates MCLK, BICK, LRCK, and SDTI from received data via AK5357's ADC. X'tal (12.288MHz) on the board is used as AK4114's reference clock.

(2-1) Set up the jumper pins.

JP4 is setting of AK5357's Audio interface format. In case of the AK5357 evaluation using the AK4114, it is necessary to correspond to the audio interface format for AK5357 (SDTO) and AK4114 (DAUX).

About AK5357's audio interface format, refer to Table. 4 on this page. About AK4114's audio interface format, refer to Table. 6 on page 8.

(Note) AK5357's default setting of Audio interface format is I²S Compatible.

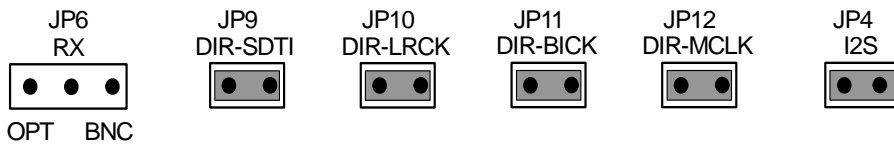

	JP4 I2S	
Open	24bit MSB Justified	<Default>
Short	I ² S Compatible	

Table. 4 ADC Output Audio Interface Format Setting

(2-2) Set up the DIP SW (S2).

In case of the AK4145 evaluation using the AK4114, it is necessary to correspond to the audio interface format for AK4145 (SDTI) and AK4114 (SDTO). About AK4145's audio interface format, refer to datasheet of AK4145. About AK4114's audio interface format, refer to Table. 6 on page 8.

(Note) AK4145's default setting of Audio interface format is I²S Compatible in parallel mode.

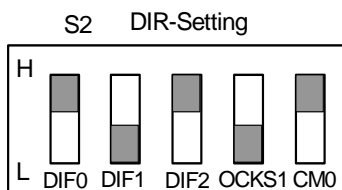

3. All interface signals are fed externally

Measurement path :

PORT2 → AK4145

Please supply MCLK, BICK, LRCK and SDTI to PORT2.

(3-1) Set up the jumper pins.

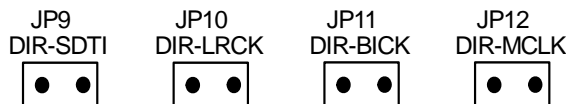

■ Setting of DIP SW

No.	Name	ON (“H”)	OFF (“L”)	Default
1	DIF0	Output Audio Interface Format : refer to Table. 6		H
2	DIF1			L
3	DIF2			H
4	OCKS1	Master Clock Frequency Setting : refer to Table. 7		L
5	CM0	Clock Mode Setting : refer to Table. 8		L

Table. 5 AK4114 Mode Setting

DIF2	DIF1	DIF0	DAUX	SDTO	LRCK	BICK
0	0	0	24bit, Left justified	16bit, Right justified	H/L	64fs
0	0	1	24bit, Left justified	18bit, Right justified	H/L	64fs
0	1	0	24bit, Left justified	20bit, Right justified	H/L	64fs
0	1	1	24bit, Left justified	24bit, Right justified	H/L	64fs
1	0	0	24bit, Left justified	24bit, Left justified	H/L	64fs
1	0	1	24bit, I ² S	24bit, I ² S	L/H	64fs

Table. 6 AK4114 Audio Data Format

OCKS1	MCKO1
L	256fs
H	512fs

Table. 7 AK4114 Master Clock Output Frequency

CM0	PLL	Clock Souce	SDTO
L	ON	PLL	RX
H	OFF	X'tal	DAUX

Table. 8 AK4114 Clock Operation Mode

■ Baseband Composite Audio signal output circuit

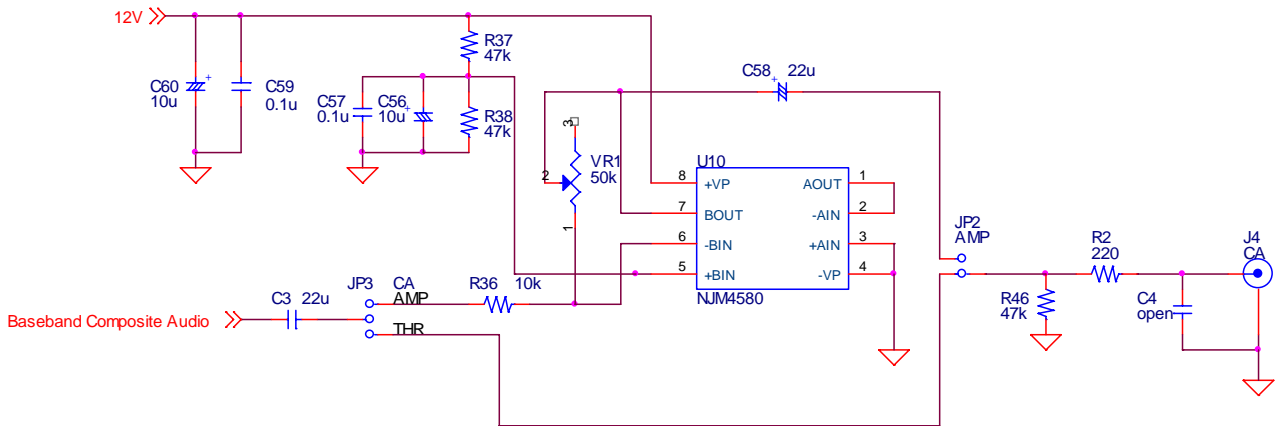
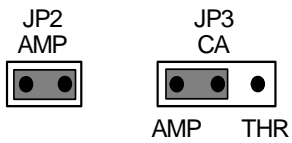

Figure. 3 Baseband Composite Audio signal output circuit

1. In case of amplification using the OP-Amp. <Default>

The stereo separation can be maximized by adjusting the variable resistor (VR1).
The jumper pins should be set as follows.



2. In case of through.

This mode is out of use.

Control Software Manual

■ Set-up of evaluation board and control software

1. Set up the AKD4145-A according to previous term.
2. Connect IBM-AT compatible PC with AKD4145-A by 10-line type flat cable (packed with AKD4145-A). Take care of the direction of 10pin header. (Please install the driver in the CD-ROM when this control software is used on Windows 2000/XP. Please refer "Installation Manual of Control Software Driver by AKM device control software". In case of Windows95/98/ME, this installation is not needed. This control software does not operate on Windows NT.)
3. Insert the CD-ROM labeled "AK4145-A Evaluation Kit" into the CD-ROM drive.
4. Access the CD-ROM drive and double-click the icon of "akd4145.exe" to set up the control program.
5. Then please evaluate according to the follows.

■ Operation flow

Keep the following flow.

1. Set up the control program according to explanation above.
2. Click "Port Reset" button.
3. Click "Write default" button

■ Explanation of each buttons

[Port Reset] :	Set up the USB interface board (AKDUSBIF-A) .
[Write default] :	Initialize the register of AK4145.
[All Write] :	Write all registers that is currently displayed.
[All Read] :	Read all registers of the AK4145.
[Function1] :	Dialog to write data by keyboard operation.
[Function2] :	Dialog to write data by keyboard operation.
[Function3] :	The sequence of register setting can be set and executed.
[Function4] :	The sequence that is created on [Function3] can be assigned to buttons and executed.
[Function5]:	The register setting that is created by [SAVE] function on main window can be assigned to buttons and executed.
[SAVE] :	Save the current register setting.
[OPEN] :	Write the saved values to all register.
[Write] :	Dialog to write data by mouse operation.
[Read]:	Dialog to read data by mouse operation.

■ Indication of data

Input data is indicated on the register map. Red letter indicates "H" or "1" and blue one indicates "L" or "0". Blank is the part that is not defined in the datasheet.

■ Explanation of each dialog

1. [Write Dialog] : Dialog to write data by mouse operation

There are dialogs corresponding to each register.

Click the [Write] button corresponding to each register to set up the dialog. If you check the check box, data becomes "H" or "1". If not, "L" or "0".

If you want to write the input data to AK4145, click [OK] button. If not, click [Cancel] button.

2. [Function1 Dialog] : Dialog to write data by keyboard operation

Address Box: Input registers address in 2 figures of hexadecimal.

Data Box: Input registers data in 2 figures of hexadecimal.

If you want to write the input data to AK4145, click [OK] button. If not, click [Cancel] button.

3. [Function2 Dialog] : Dialog to evaluate DVOL

Address Box: Input registers address in 2 figures of hexadecimal.

Start Data Box: Input starts data in 2 figures of hexadecimal.

End Data Box: Input end data in 2 figures of hexadecimal.

Interval Box: Data is written to AK4145 by this interval.

Step Box: Data changes by this step.

Mode Select Box:

If you check this check box, data reaches end data, and returns to start data.

[Example] Start Data = 00, End Data = 09

Data flow: 00 01 02 03 04 05 06 07 08 09 09 08 07 06 05 04 03 02 01 00

If you do not check this check box, data reaches end data, but does not return to start data.

[Example] Start Data = 00, End Data = 09

Data flow: 00 01 02 03 04 05 06 07 08 09

If you want to write the input data to AK4145, click [OK] button. If not, click [Cancel] button.

4. [Save] and [Open]

4-1. [Save]

Save the current register setting data. The extension of file name is “akr”.

<Operation flow>

- (1) Click [Save] Button.
- (2) Set the file name and push [Save] Button. The extension of file name is “akr”.

4-2. [Open]

The register setting data saved by [Save] is written to AK4145. The file type is the same as [Save].

<Operation flow>

- (1) Click [Open] Button.
- (2) Select the file (*.akr) and Click [Open] Button.

5. [Function3 Dialog]

The sequence of register setting can be set and executed.

(1) Click [F3] Button.

(2) Set the control sequence.

Set the address, Data and Interval time. Set “-1” to the address of the step where the sequence should be paused.

(3) Click [Start] button. Then this sequence is executed.

The sequence is paused at the step of Interval="-1". Click [START] button, the sequence restarts from the paused step.

This sequence can be saved and opened by [Save] and [Open] button on the Function3 window. The extension of file name is “aks”.

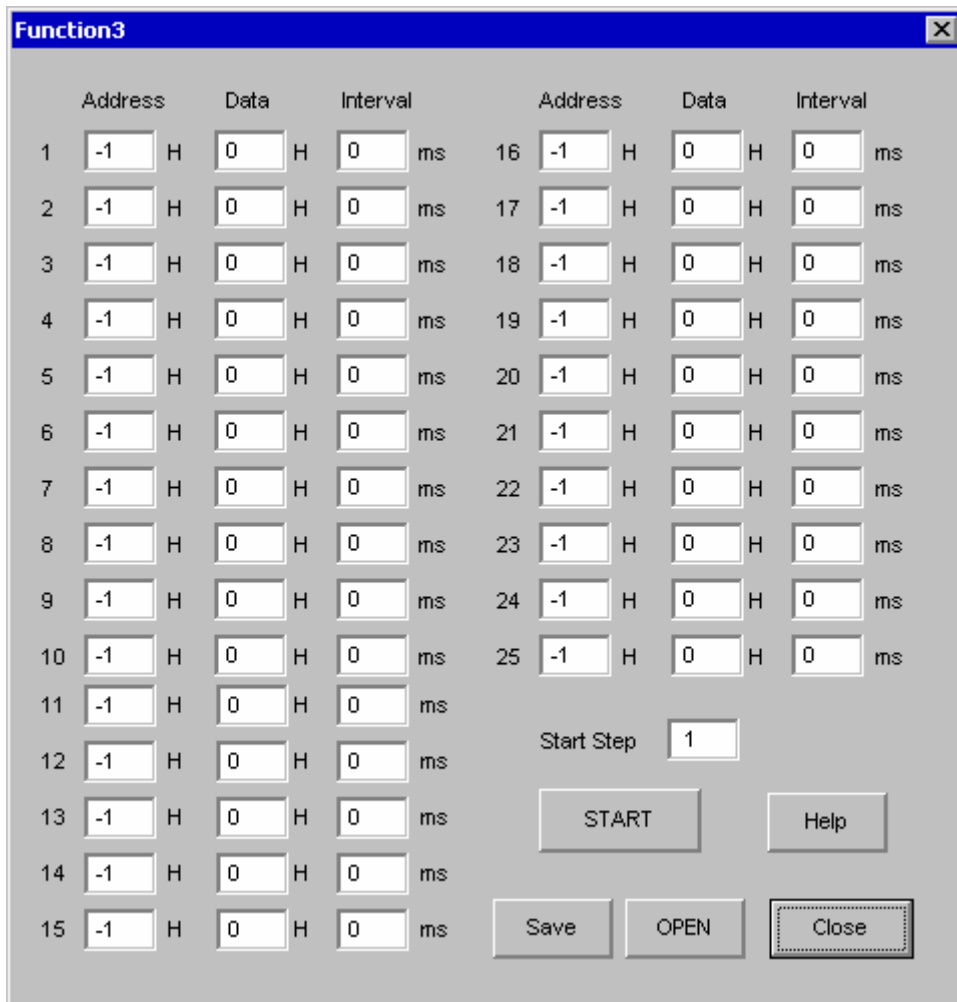

Figure. 4 Window of [F3]

6. [Function4 Dialog]

The sequence that is created on [Function3] can be assigned to buttons and executed. When [F4] button is clicked, the window as shown in Figure. 5 opens.

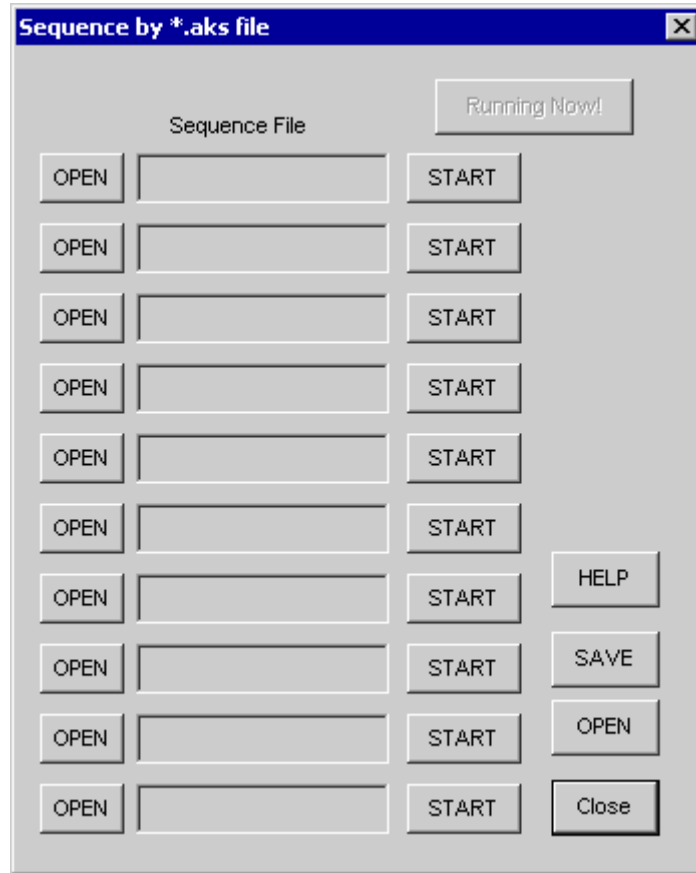

Figure. 5 [F4] window

6-1. [OPEN] buttons on left side and [START] buttons

(1) Click [OPEN] button and select the sequence file (*.aks).

The sequence file name is displayed as shown in Figure. 6

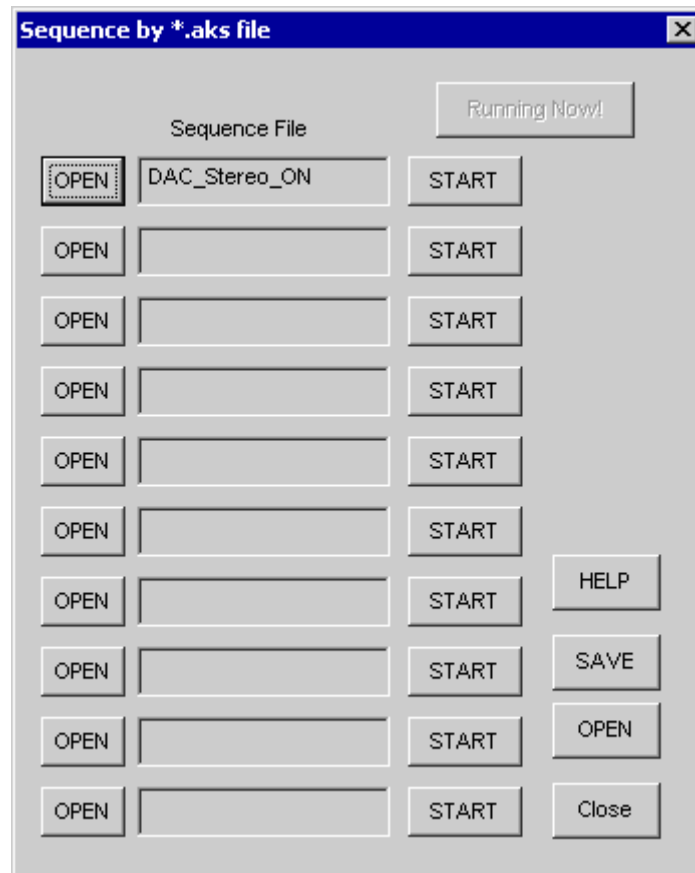

Figure. 6 [F4] window (2)

(2) Click [START] button, then the sequence is executed.

6-2. [SAVE] and [OPEN] buttons on right side

[SAVE] : The sequence file names can assign be saved. The file name is *.ak4.

[OPEN] : The sequence file names assign that are saved in *.ak4 are loaded.

6-3. Note

(1) This function doesn't support the pause function of sequence function.

(2) All files need to be in same folder used by [SAVE] and [OPEN] function on right side.

(3) When the sequence is changed in [Function3], the file should be loaded again in order to reflect the change.

7. [Function5 Dialog]

The register setting that is created by [SAVE] function on main window can be assigned to buttons and executed. When [F5] button is clicked, the following window as shown in Figure. 7 opens.

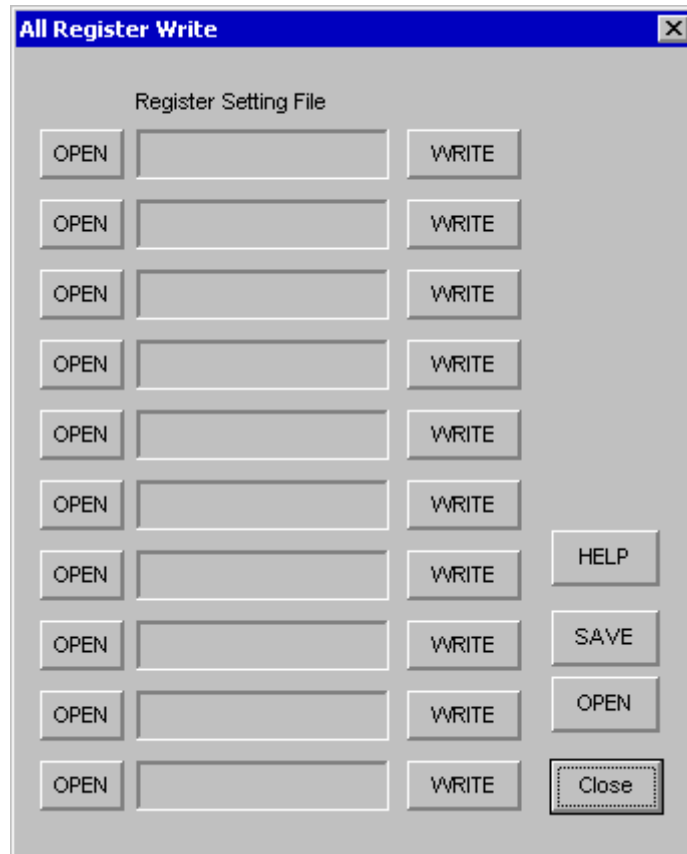

Figure. 7 [F5] window

7-1. [OPEN] buttons on left side and [WRITE] button

(1) Click [OPEN] button and select the register setting file (*.akr).

The register setting file name is displayed as shown in Figure. 8

(2) Click [WRITE] button, then the register setting is executed.

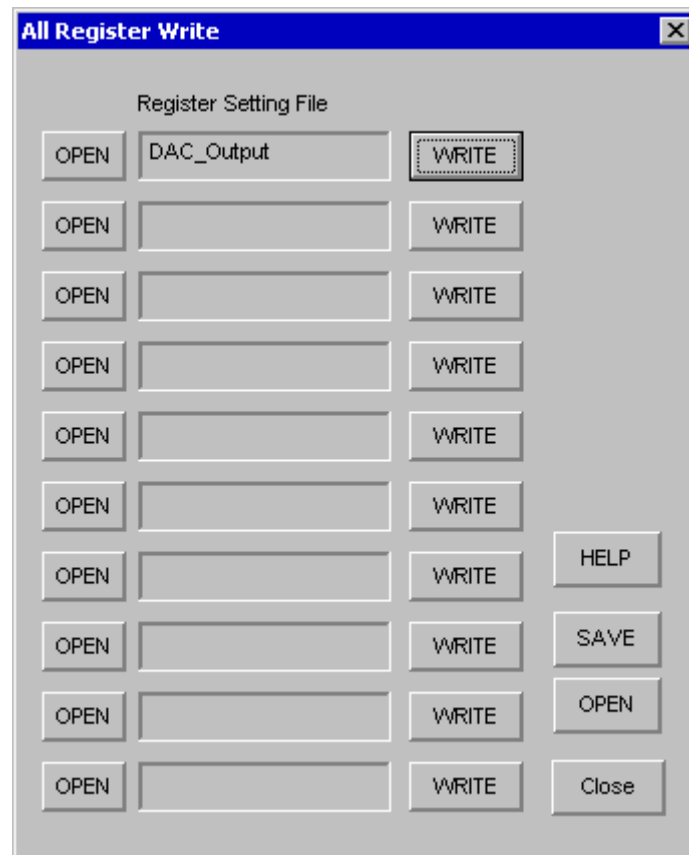

Figure. 8 [F5] windows(2)

7-2. [SAVE] and [OPEN] buttons on right side

[SAVE] : The register setting file names assign can be saved. The file name is *.ak5.

[OPEN] : The register setting file names assign that are saved in *.ak5 are loaded.

7-3. Note

- (1) All files need to be in same folder used by [SAVE] and [OPEN] function on right side.
- (2) When the register setting is changed by [Save] Button in main window, the file should be loaded again in order to reflect the change.

MEASUREMENT RESULTS

[Measurement condition]

- Measurement unit : Audio Precision, System Two Cascade
BELAR TV DIGITAL SETEREO MONITOR TVM-230
- MCLK : 256fs
- BICK : 64fs
- fs : 48kHz
- Bit : 24bit
- Power Supply : AVDD = TVDD = 3.3V, DVDD = 1.8V
- Temperature : Room

[Measurement Results]

Parameter		Result (Lch / Rch)	Unit
S/(N+D) (-1dB Input, 1kHz)	Mono	-79.5	dB
	Stereo	-77.9 / -78.5	
S/N (Input off, A-weighting)	Mono	-80.9	dB
	Stereo	-81.3 / -81.3	
Stereo Separation (-1dB Input, 1kHz)	Stereo	49.4 / 48.5	dB

[Performance Plots]

Stereo :

- Figure. 9 : THD+N vs. Input Level (1kHz)
- Figure. 10 : THD+N vs. Input Frequency (-15dB)
- Figure. 11 : Linearity (1kHz)
- Figure. 12 : Frequency Response (-15dB)
- Figure. 13 : Separation (Left Channel = Off, Right Channel = -15dB)
- Figure. 14 : FFT Plot (-1dB)
- Figure. 15 : FFT Plot (No Signal)

Mono :

- Figure. 16 : THD+N vs. Input Level (1kHz)
- Figure. 17 : THD+N vs. Input Frequency (-15dB)
- Figure. 18 : Linearity (1kHz)
- Figure. 19 : Frequency Response (-15dB)
- Figure. 20 : FFT Plot (-1dB)
- Figure. 21 : FFT Plot (No Signal)

[Stereo]

THD + N vs Input Level

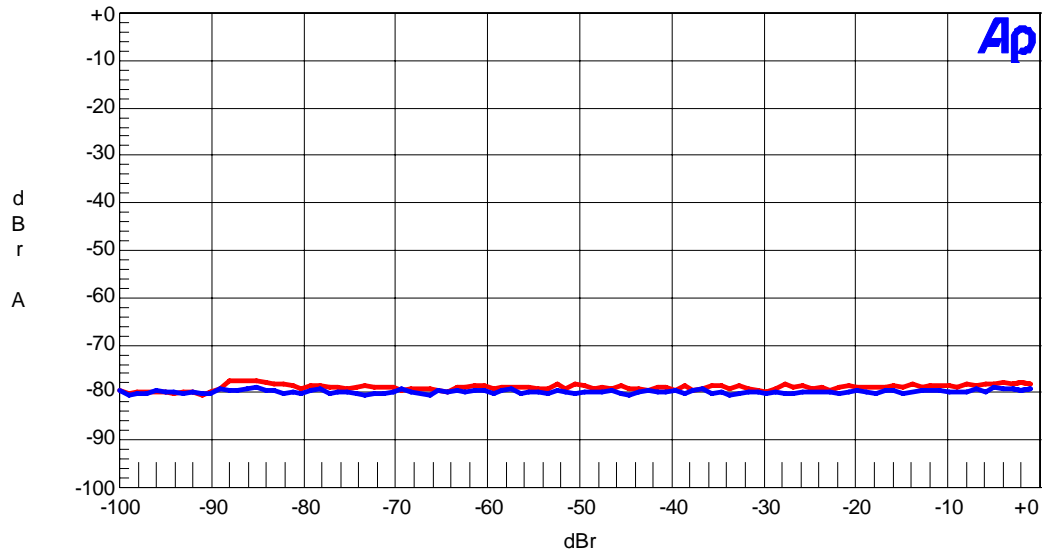

Figure. 9 Stereo mode THD + N vs. Input Level (fin=1kHz)

THD + N vs Input Frequency

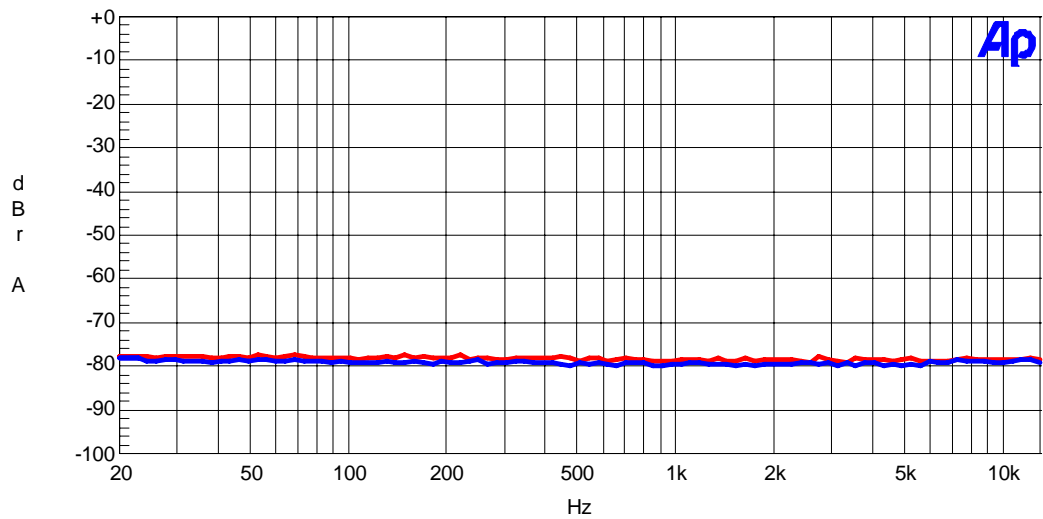

Figure. 10 Stereo mode THD + N vs. Input Frequency (-15dB)

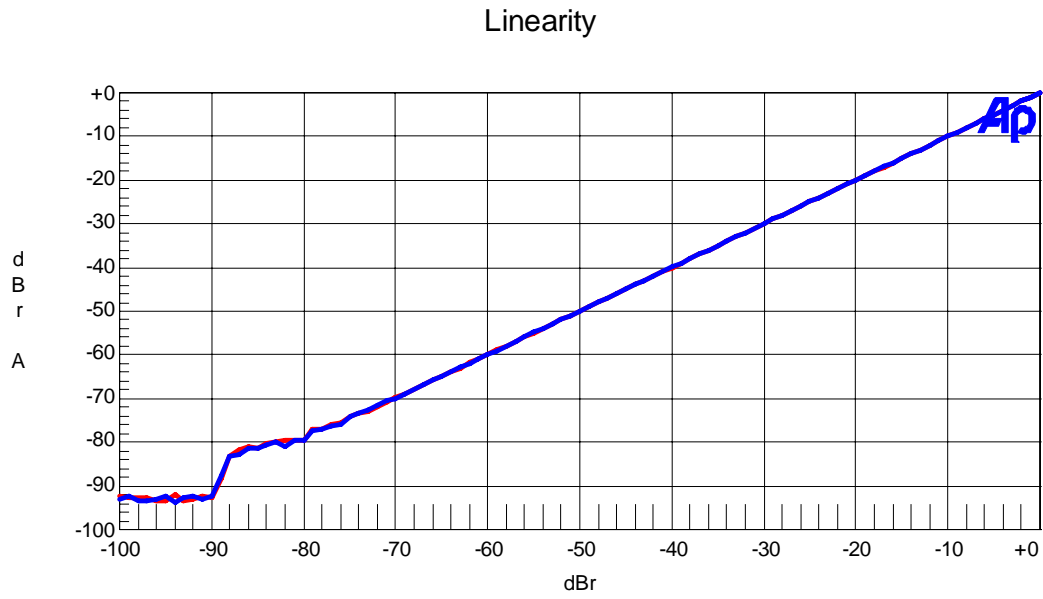

Figure. 11 Stereo mode Linearity (fin=1kHz)

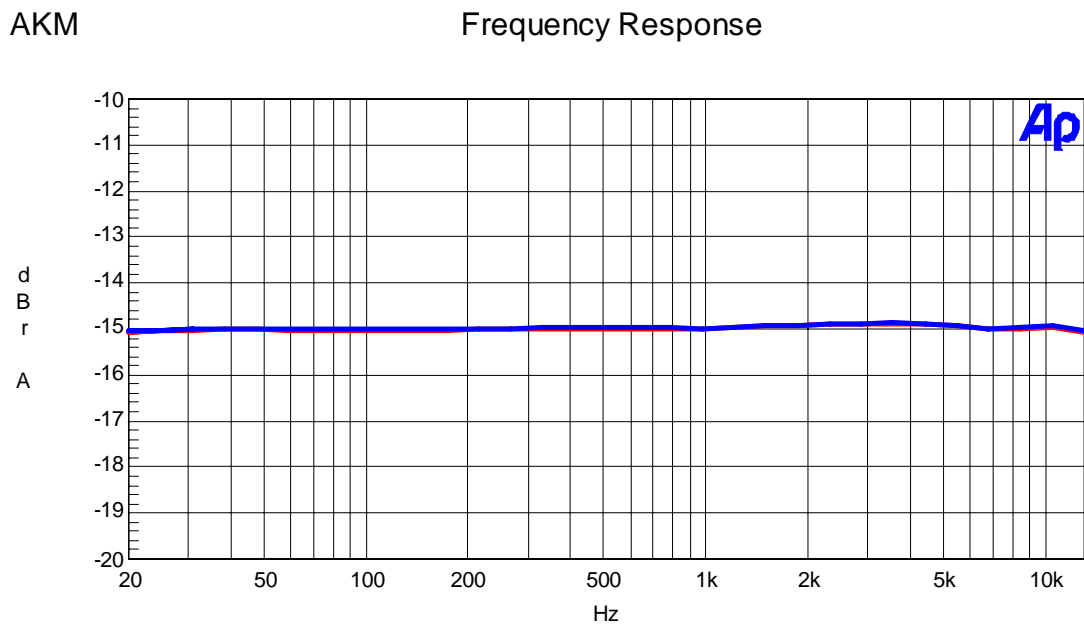

Figure. 12 Stereo mode Frequency Response (-15dB)

AKM Stereo Separation (Lch Off, Rch -15dB)

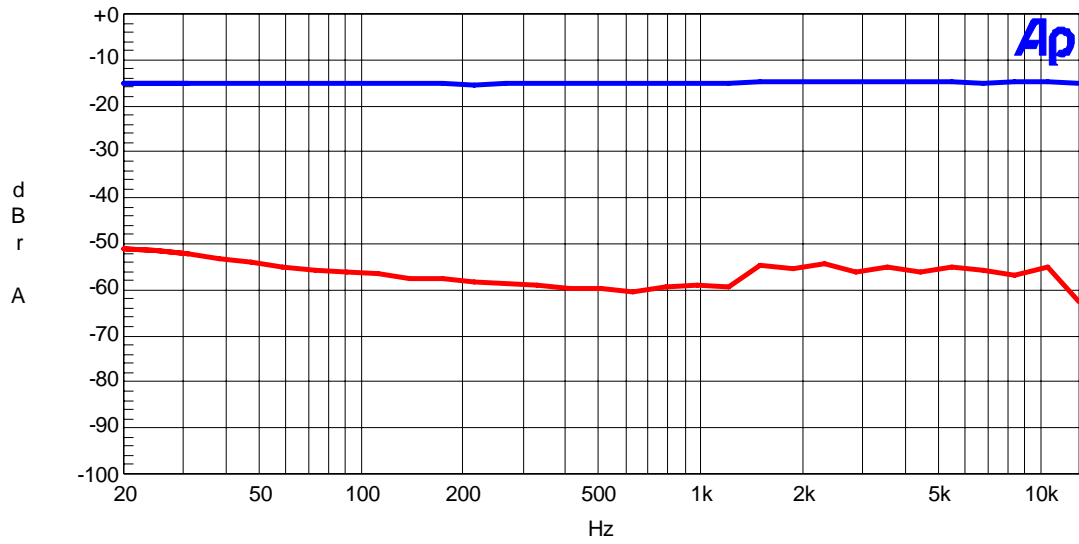

Figure. 13 Stereo Separation (Lch Off, Rch -15dB)

FFT (-1dB)

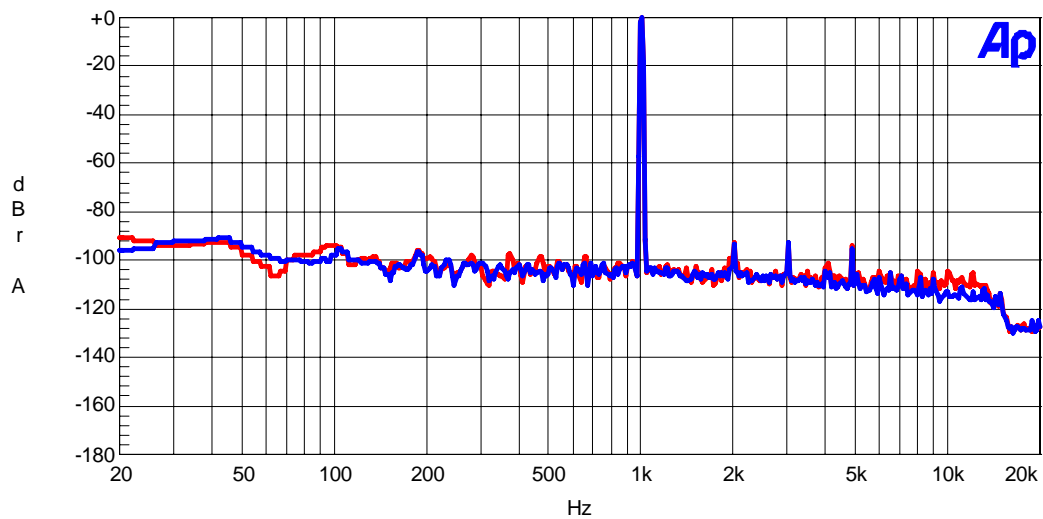

Figure. 14 Stereo mode FFT Plot (-1dB)

FFT (No Signal)

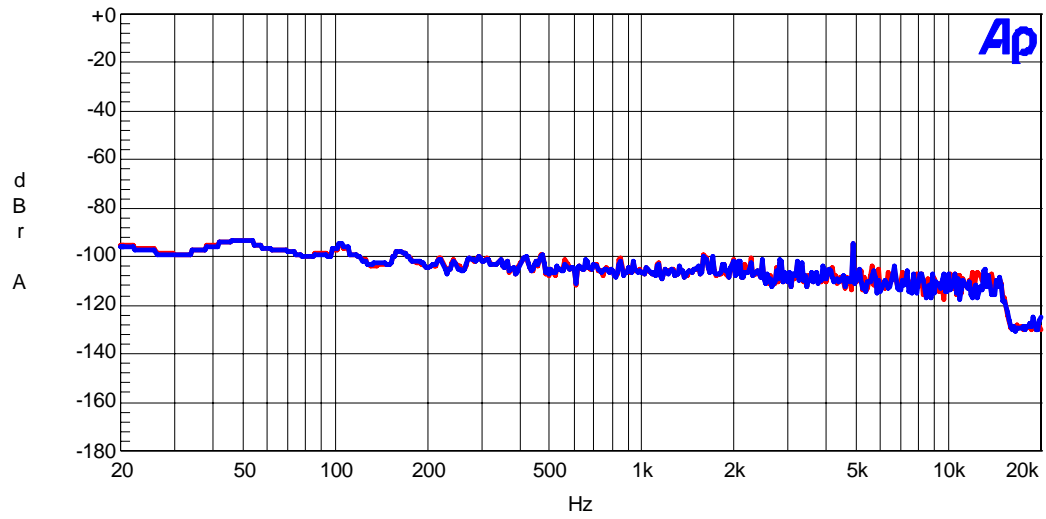

Figure. 15 Stereo mode FFT Plot (No Signal)

[Mono]

THD + N vs Input Level

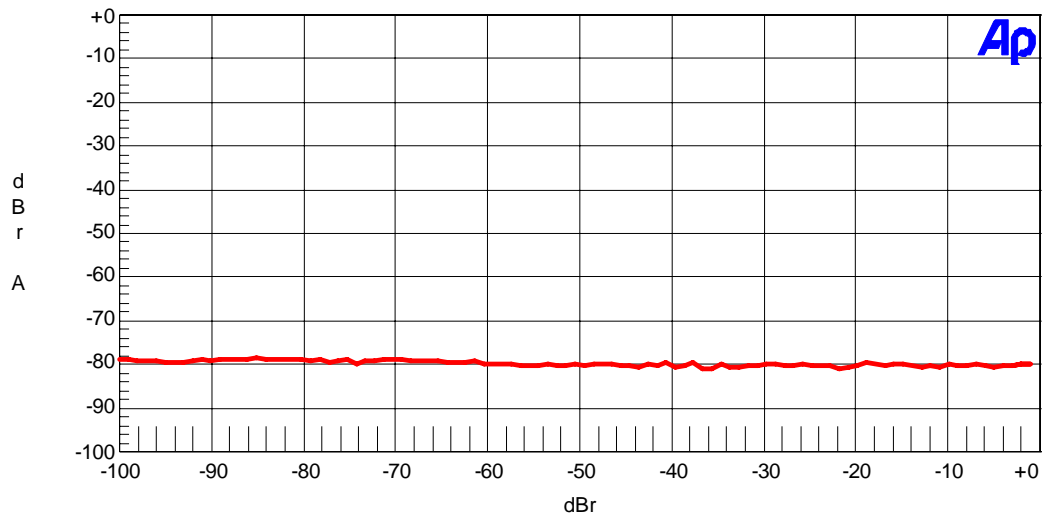

Figure. 16 Mono mode THD + N vs. Input Level (fin=1kHz)

THD + N vs Input Frequency

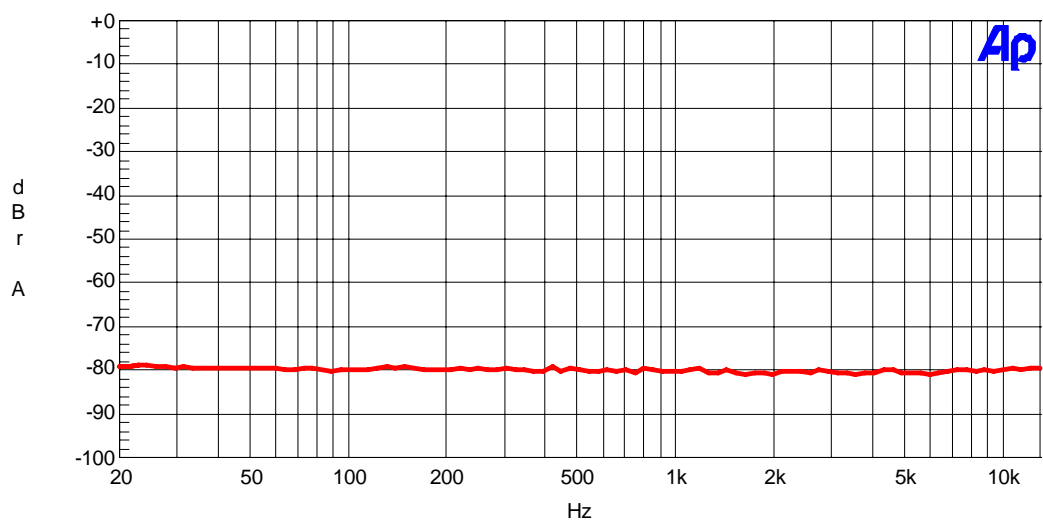

Figure. 17 Mono mode THD + N vs. Input Frequency (-15dB)

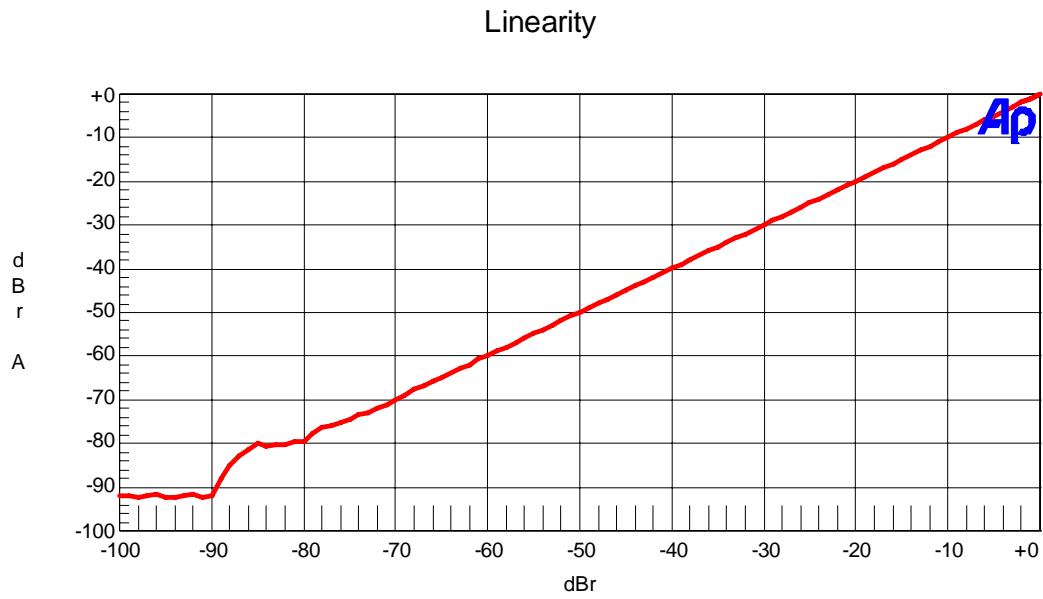

Figure. 18 Mono mode Linearity (fin=1kHz)

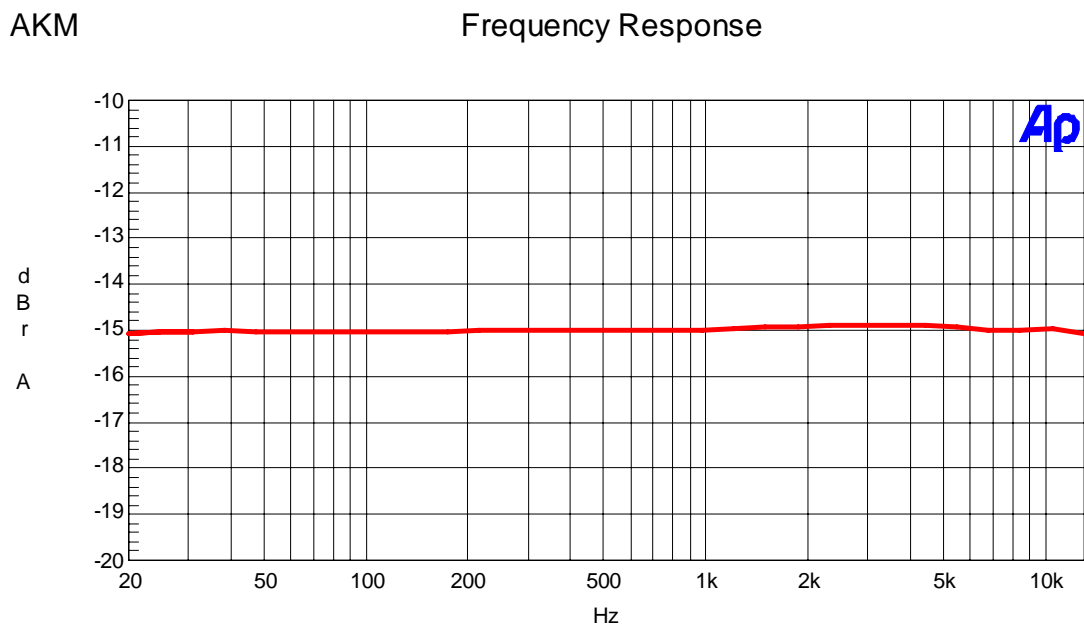

Figure. 19 Mono mode Frequency Response (-15dB)

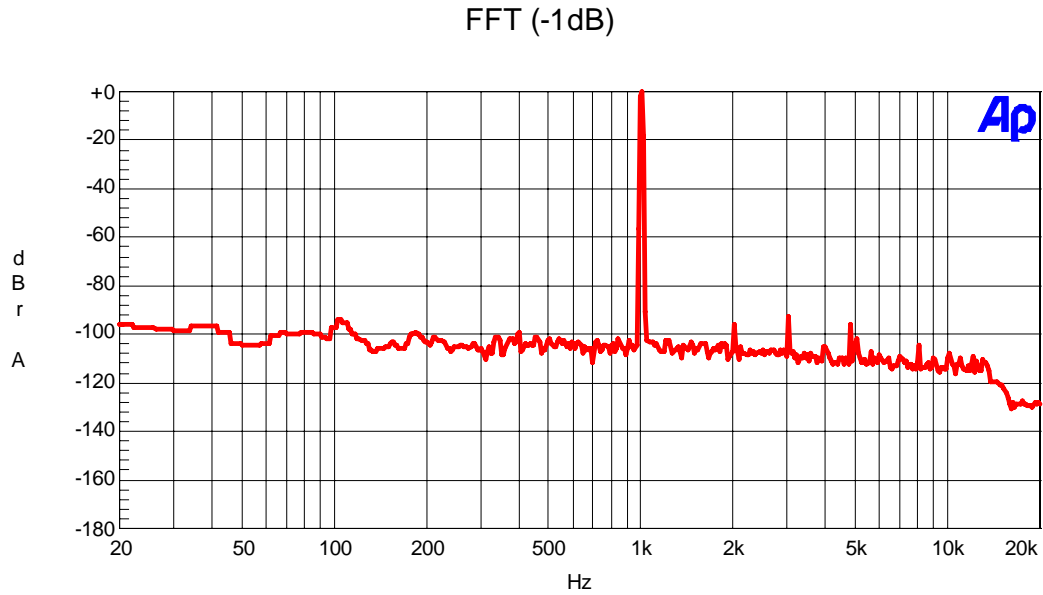

Figure. 20 Mono mode FFT Plot (-1dB)

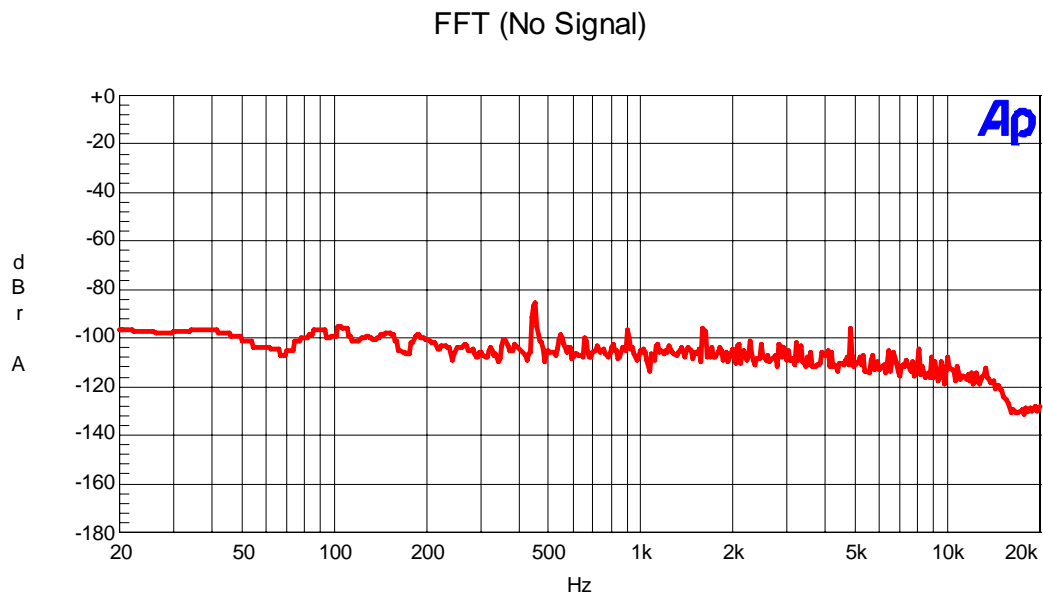

Figure. 21 Mono mode FFT Plot (No Signal)

Revision History

Date (yy/mm/dd)	Manual Revision	Board Revision	Reason	Page	Contents
07/09/07	KM090000	0	First Edition		
08/03/10	KM090001	1	Change		Device revision was changed. Rev.A → Rev.B
			Change	18-25	Table data and Plot data were changed.
08/06/05	KM090002	2	Change		Device revision was changed. Rev.B → Rev.C
			Change	18-25	Table data and Plot data were changed.
			Change	3-8	Default setting of Audio I/F was changed. MSB Justified → I ² S Compatible
08/08/18	KM090003	3	Change	27	Circuit diagram was changed. R47 was added. (P/S pin Pull up)
			Change	18-25	Table data and Plot data were changed.

IMPORTANT NOTICE

- These products and their specifications are subject to change without notice.
When you consider any use or application of these products, please make inquiries the sales office of Asahi Kasei EMD Corporation (AKEMD) or authorized distributors as to current status of the products.
- AKEMD assumes no liability for infringement of any patent, intellectual property, or other rights in the application or use of any information contained herein.
- Any export of these products, or devices or systems containing them, may require an export license or other official approval under the law and regulations of the country of export pertaining to customs and tariffs, currency exchange, or strategic materials.
- AKEMD products are neither intended nor authorized for use as critical components_{Note1)} in any safety, life support, or other hazard related device or system_{Note2)}, and AKEMD assumes no responsibility for such use, except for the use approved with the express written consent by Representative Director of AKEMD. As used here:
 Note1) A critical component is one whose failure to function or perform may reasonably be expected to result, whether directly or indirectly, in the loss of the safety or effectiveness of the device or system containing it, and which must therefore meet very high standards of performance and reliability.
 Note2) A hazard related device or system is one designed or intended for life support or maintenance of safety or for applications in medicine, aerospace, nuclear energy, or other fields, in which its failure to function or perform may reasonably be expected to result in loss of life or in significant injury or damage to person or property.
- It is the responsibility of the buyer or distributor of AKEMD products, who distributes, disposes of, or otherwise places the product with a third party, to notify such third party in advance of the above content and conditions, and the buyer or distributor agrees to assume any and all responsibility and liability for and hold AKEMD harmless from any and all claims arising from the use of said product in the absence of such notification.

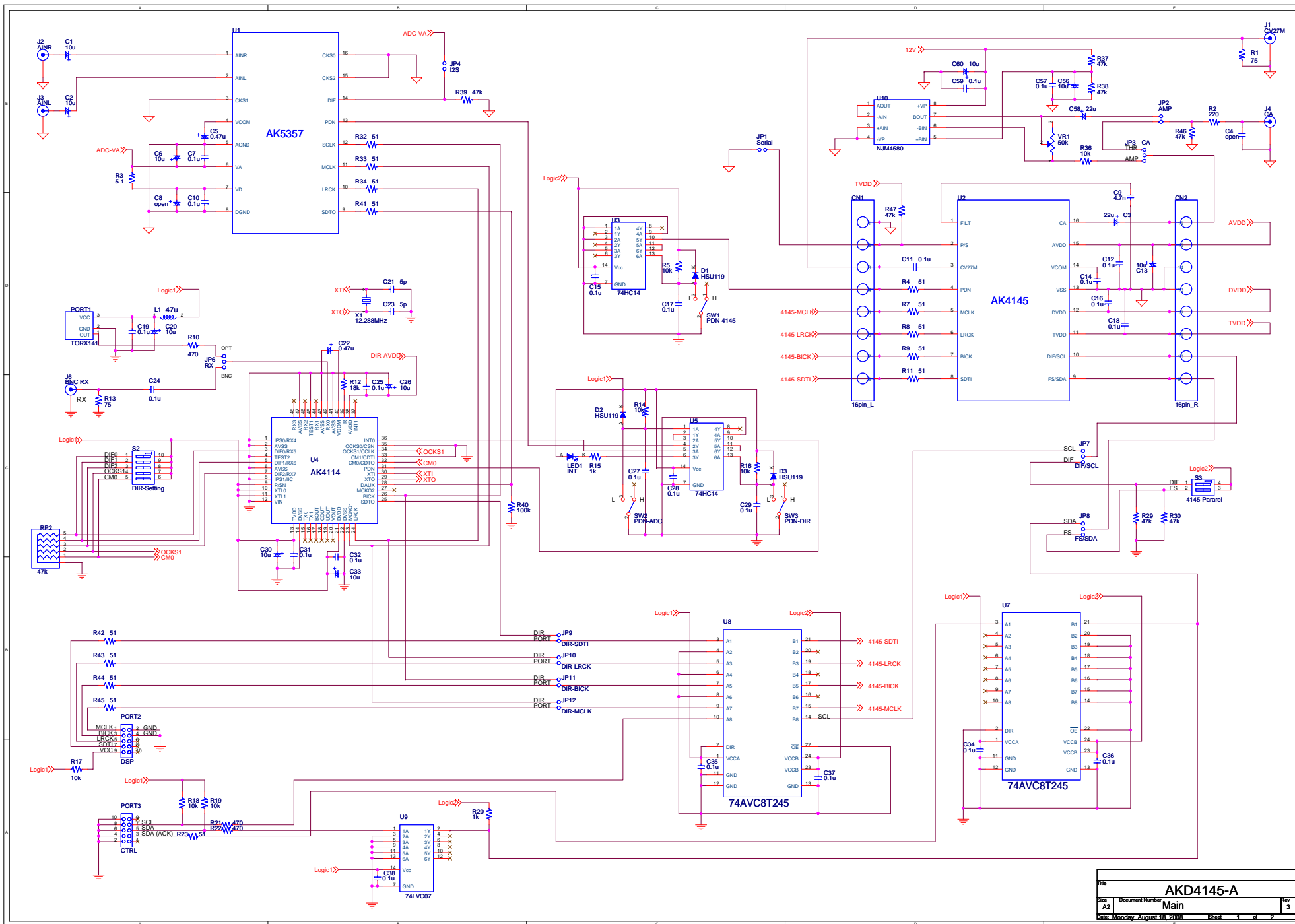

File	AKD4145-A		Rev
Size	Document Number	Main	3
AD			
Rev	Monday, August 1A, 2008	Sheet	1 of 2

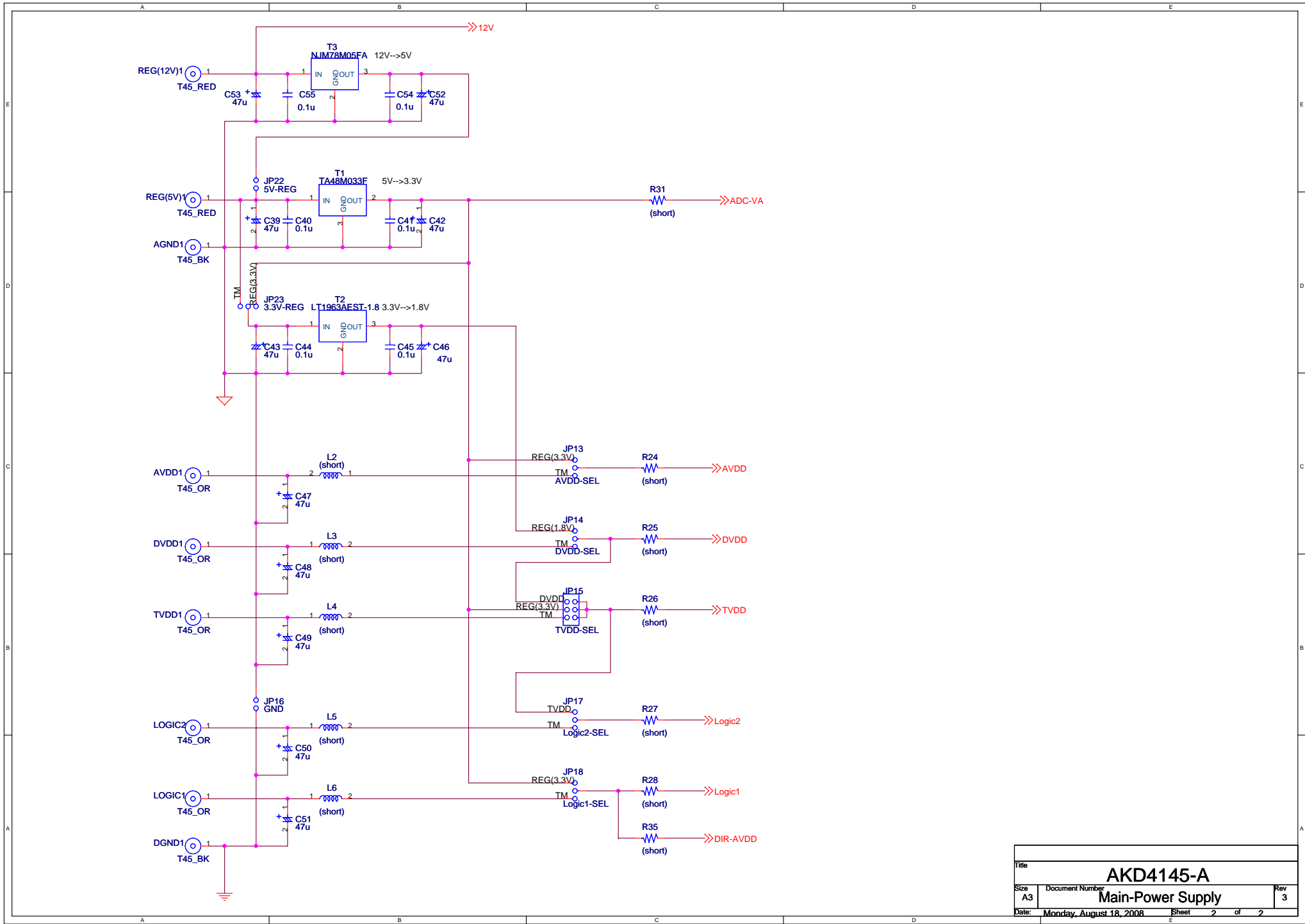

Title			
AKD4145-A			
Size	Document Number	Rev	
A3	Main-Power Supply	3	
Date:	Monday, August 18, 2008	Sheet	2 of 2

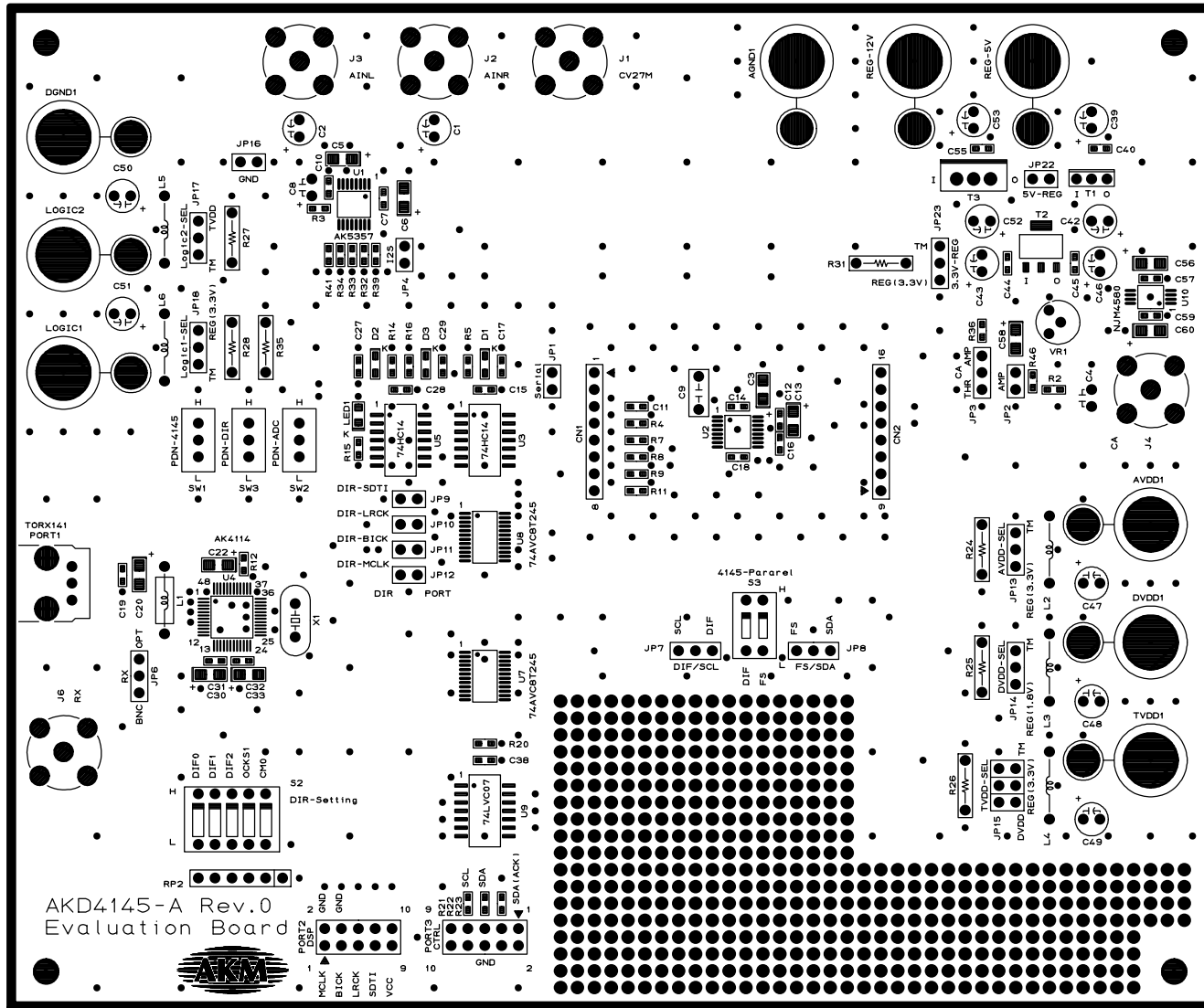

AKD4145-A L1 SILK

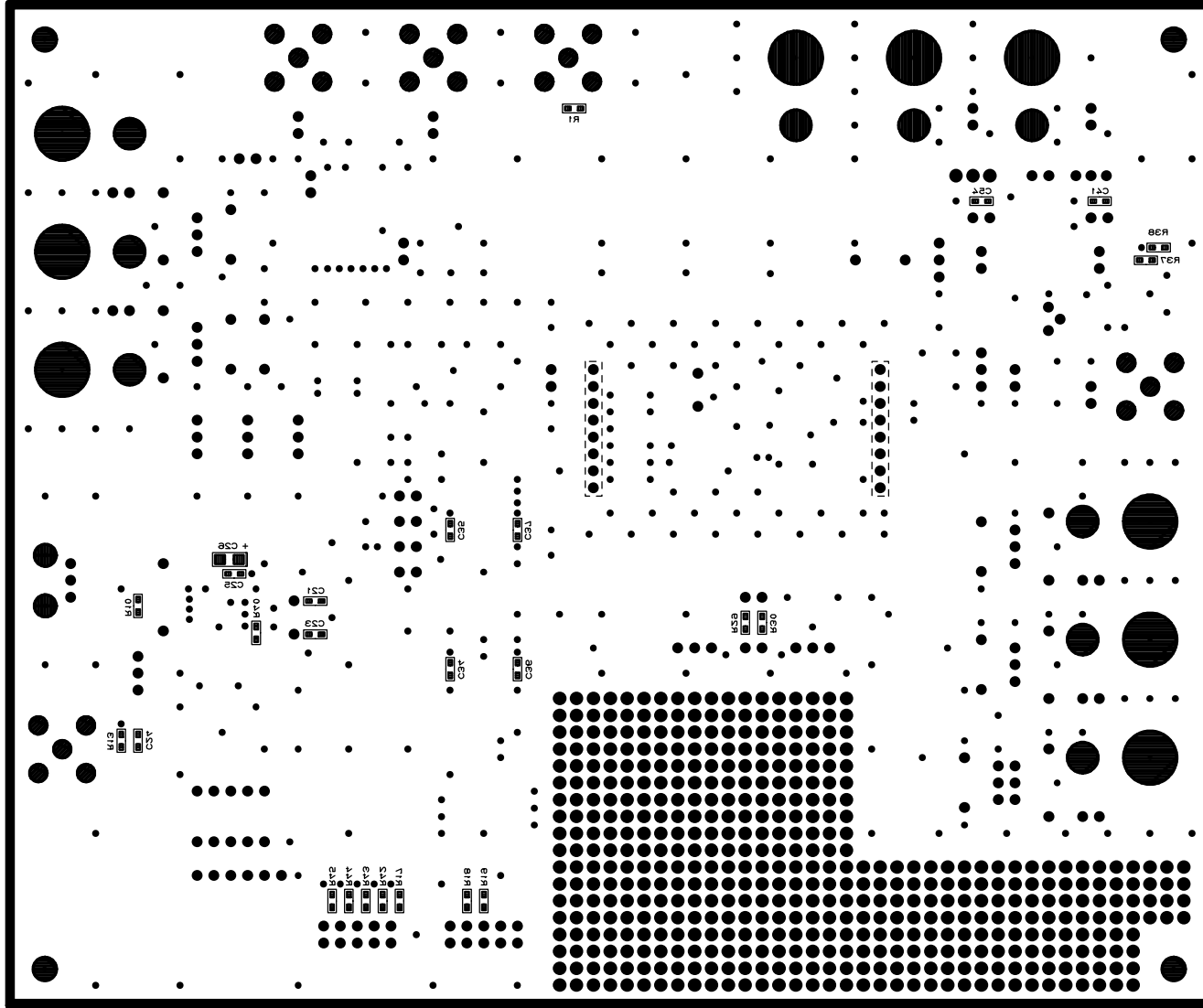

AKD4142-A-LS 21LK

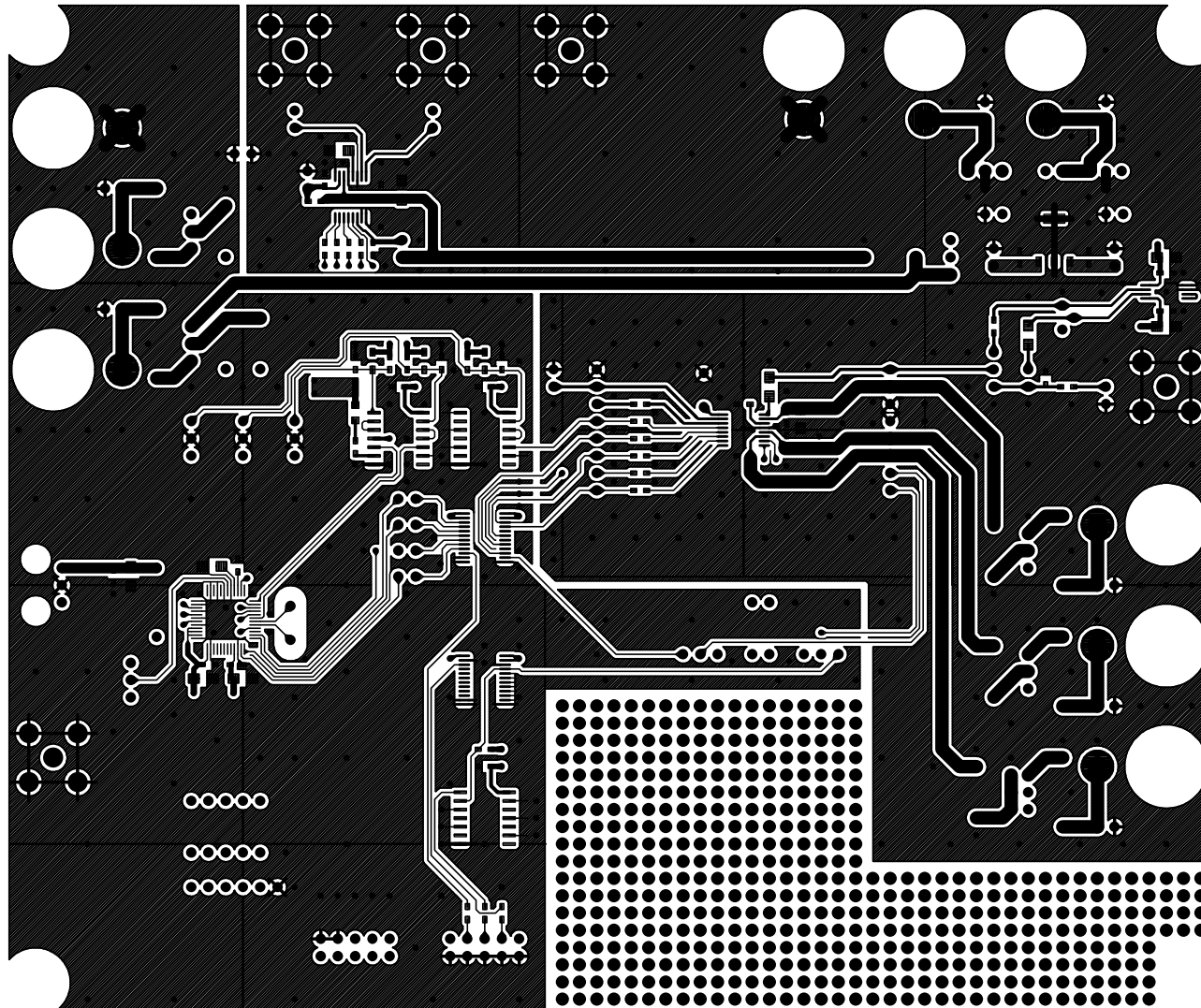

AKD4145-A L1

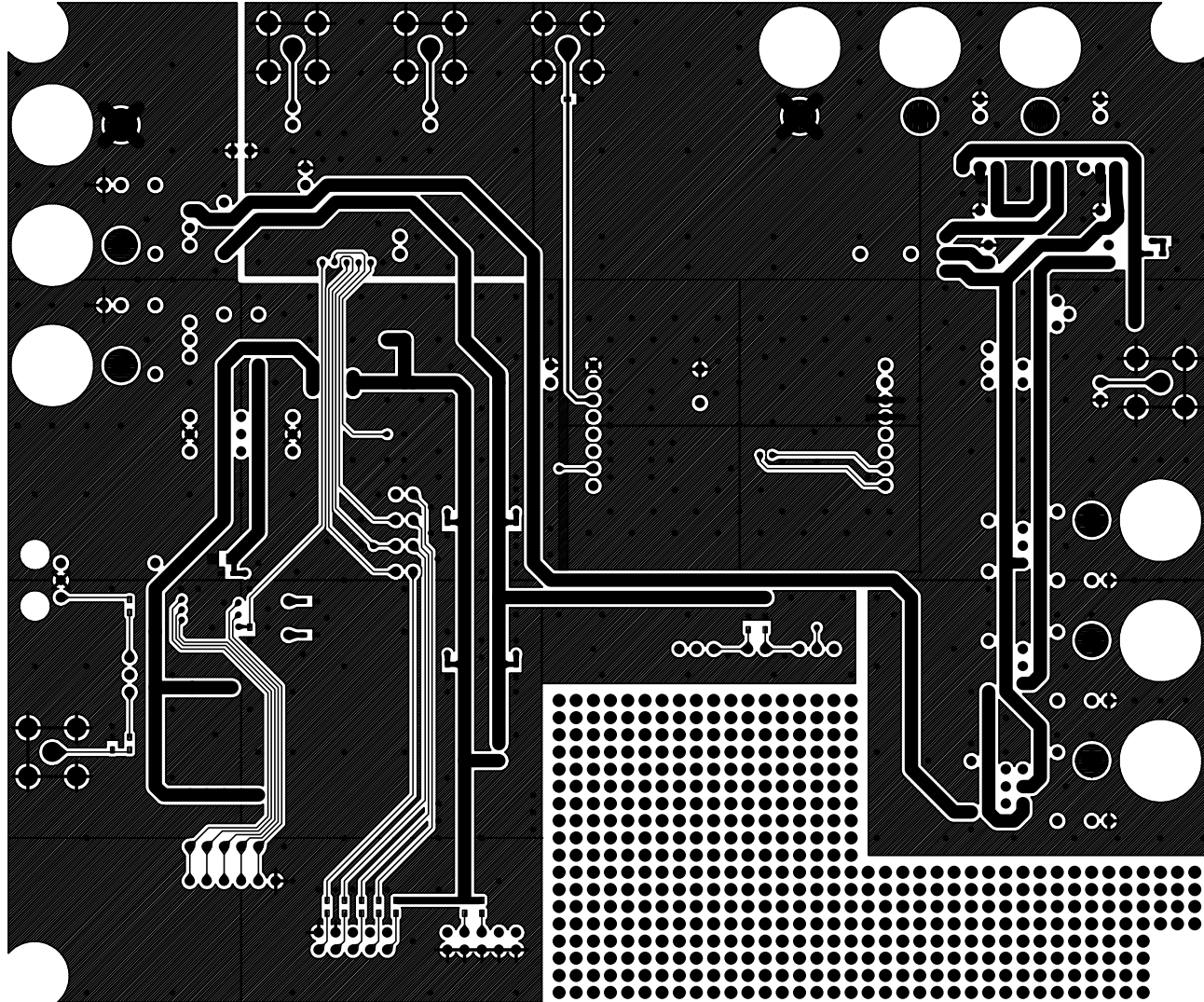

KD4142-A-LS