



AK4220

7:3 Audio Switch and 6:3 Video Switch

GENERAL DESCRIPTION

The AK4220 is an AV Switch with 7:3 Audio Switches and 6:3 Video Switches. Using CMOS process to offer the high performance with low power consumption. In the Audio section, on-chip differential input circuit could separate the external ground noise. The AK4220 integrates a pop noise free circuit for power on/pff. The AK4220 is offered in a space saving 64-pin LQFP package, ideal for car navigation applications.

FEATURES

1. Audio Section

- Selector for 7 inputs and 3 outputs
- Differential Input Circuit for Ground Noise Cannel
- THD+N: -92dB (@1Vrms)
- Dynamic Range: 96dB
- Channel-Independent Output Off
- Pop Noise Free Circuit for Power On/Off
- Channel-Independent Input Detection Circuit

2. Video Section

- Selector for 6 inputs and 3 outputs
- Six Composite Signal Inputs
- Video Driver for Composite Signal Output (+6dB)
- Channel-Independent Hi-Z Output
- On-Chip Sync-tip Clamp Circuit
- Frequency Range: 6MHz
- S/N: 74dB
- Input Detection Circuit

3. Control Section

- Serial μ P I/F (I²C, 4-wires serial)
- Five Programmable Output pins

4. Power Supply

- Analog: 4.5V ~ 5.5V
- Digital: 3.0V ~ 3.6V
- Low Power Consumption: 186mW

5. Ta = -40 ~ 85 °C

6. Package: 64pin LQFP

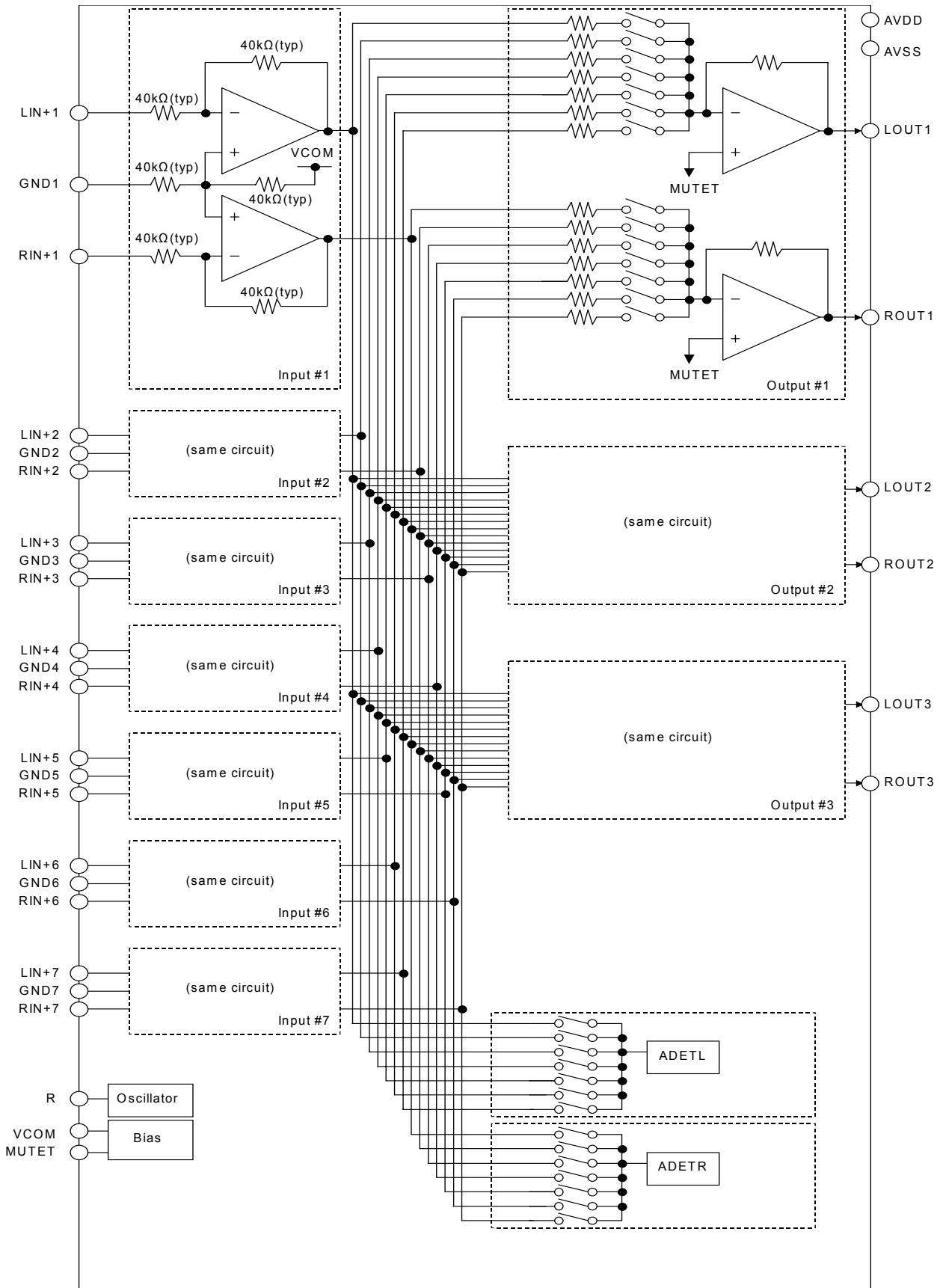

Figure 1. Audio Block

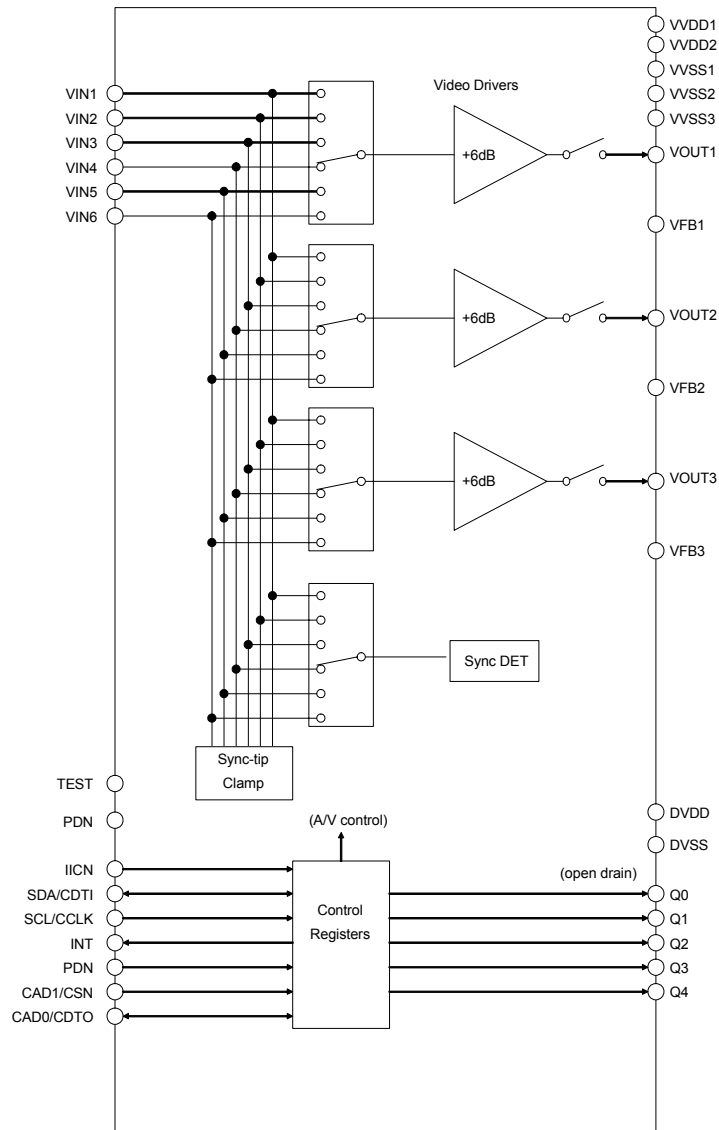

Figure 2. Video & Control Block

PIN/FUNCTION

No.	Pin Name	I/O	Function
1	RIN+7	I	Rch Audio Positive Input 7
2	PDN	I	Power down Mode “L”: Power down, Reset “H”: Power up The AK4220 should always be reset upon power-up.
3	CAD1	I	Chip Address1 (IICN pin = “L”)
	CSN	I	Chip Selector (IICN pin = “H”)
4	SCL	I	Control Clock Input (IICN pin = “L”)
	CCLK	I	Control Clock Input (IICN pin = “H”)
5	SDA	I/O	Control Data Input/Output (IICN pin = “L”)
	CDTI	I	Control Data Input (IICN pin = “H”)
6	CAD0	I	Chip Address0 (IICN pin = “L”)
	CDTO	O	Control Data Output (IICN pin = “H”)
7	INT	O	Interrupt
8	Q0	O	Parallel Output 0 (open drain output)
9	Q1	O	Parallel Output 1 (open drain output)
10	Q2	O	Parallel Output 2 (open drain output)
11	Q3	O	Parallel Output 3 (open drain output)
12	Q4	O	Parallel Output 4 (open drain output)
13	DVDD	-	Digital Power Supply Normally connected to DVSS with a 0.1μF ceramic capacitor in parallel with a 10μF electrolytic capacitor.
14	DVSS	-	Digital Ground
15	VOU1	O	Video Output 1
16	VFB1	I	Video Feedback 1
17	TEST	I	Test pin, Connected to VVSS.
18	VOU2	O	Video Output 2
19	VFB2	I	Video Feedback 2
20	VVDD2	-	Video Power Supply, 5V Normally connected to VVSS with a 0.1μF ceramic capacitor in parallel with a 10μF electrolytic capacitor.
21	VOU3	O	Video Output 3
22	VFB3	I	Video Feedback 3
23	VVSS2	-	Video Ground2, 0V
24	VIN1	I	Video Input 1
25	VVSS3	-	Video Ground3, 0V
26	VIN2	I	Video Input 2
27	VVDD1	-	Video Power Supply, 5V Normally connected to VVSS with a 0.1μF ceramic capacitor in parallel with a 10μF electrolytic cap.
28	VIN3	I	Video Input 3
29	VVSS1	-	Video Ground1, 0V
30	VIN4	I	Video Input 4
31	IICN	I	Control Mode Selection “L”(Connected to VVSS): IIC Bus “H” (Connected to VVDD): 4-wire Serial
32	VIN5	I	Video Input 5
33	VIN6	I	Video Input 6
34	AVDD	-	Audio Power Supply, 5V Normally connected to AVSS with a 0.1μF ceramic capacitor in parallel with a 10μF electrolytic capacitor.

PIN/FUNCTION (Continued)

35	R	O	Current Setting for Oscillator Normally connected to AVSS with a $12k\pm 1\% \Omega$ resistance.
36	MUTET	O	Audio Common Voltage Output2 Normally connected to AVSS with a $1\mu F$ ceramic capacitor.
37	VCOM	O	Audio Common Voltage Output1 (Figure 3) Normally connected to AVSS with a $0.1\mu F$ ceramic capacitor in parallel with a $2.2\mu F$ electrolytic capacitor.
38	AVSS	-	Audio Ground, 0V
39	LOUT1	O	Lch Audio Output 1
40	ROUT1	O	Rch Audio Output 1
41	LOUT2	O	Lch Audio Output 2
42	ROUT2	O	Rch Audio Output 2
43	LOUT3	O	Lch Audio Output 3
44	ROUT3	O	Rch Audio Output 3
45	GND1	I	Audio Input Ground1
46	LIN+1	I	Lch Audio Positive Input 1
47	RIN+1	I	Rch Audio Positive Input 1
48	GND2	I	Audio Input Ground 2
49	LIN+2	I	Lch Audio Positive Input 2
50	RIN+2	I	Rch Audio Positive Input 2
51	GND3	I	Audio Input Ground 3
52	LIN+3	I	Lch Audio Positive Input 3
53	RIN+3	I	Rch Audio Positive Input 3
54	GND4	I	Audio Input Ground 4
55	LIN+4	I	Lch Audio Positive Input 4
56	RIN+4	I	Rch Audio Positive Input 4
57	GND5	I	Audio Input Ground 5
58	LIN+5	I	Lch Audio Positive Input 5
59	RIN+5	I	Rch Audio Positive Input 5
60	GND6	I	Audio Input Ground 6
61	LIN+6	I	Lch Audio Positive Input 6
62	RIN+6	I	Rch Audio Positive Input 6
63	GND7	I	Audio Input Ground 7
64	LIN+7	I	Lch Audio Positive Input 7

Note: All digital input pins (PDN, CAD1-0, SCL and SDA pins) must not be left floating.

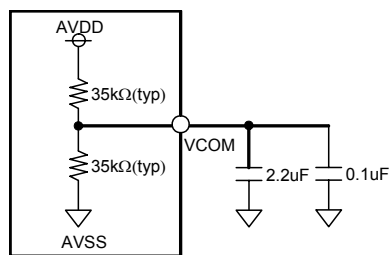

Figure 3. VCOM Circuit

■ Handling of Unused Pin

The unused I/O pins should be processed appropriately as below.

Classification	Pin Name	Setting
Analog	LIN+1-LIN+7, RIN+1-RIN+7, LOUT1-LOUT3, ROUT1-ROUT3, VIN1-VIN6, VOU1-VOUT3, VFB1-VFB3, Q0-Q4, INT	These pins should be open.
Digital	TEST	These pins should be connected to DVSS.

ABSOLUTE MAXIMUM RATINGS

(AVSS = VVSS1-3 = DVSS = 0V; Note: 1)

Parameter	Symbol	min	max	Units	
Power Supplies	Audio	AVDD	-0.3	6.0	V
	Video	VVDD1	-0.3	6.0	V
	Video	VVDD2	-0.3	6.0	V
	Digital	DVDD	-0.3	6.0	V
	AVSS-DVSS (Note: 2)	ΔGND1	-	0.3	V
	AVSS-VVSS1 (Note: 2)	ΔGND2	-	0.3	V
	AVSS-VVSS2 (Note: 2)	ΔGND3	-	0.3	V
AVSS-VVSS3 (Note: 2)	ΔGND4	-	0.3	V	
Input Current (any pins except for supplies)	IIN	-	±10	mA	
Audio Input Voltage (LIN+1-7, RIN+1-7, GND1-7 pins)	VINA	-0.3	AVDD+0.3	V	
Video Input Voltage1 (VIN1-6, IICN pins)	VINV1	-0.3	VVDD1+0.3	V	
Video Input Voltage2 (VFB1-3, TEST pins)	VINV2	-0.3	VVDD2+0.3	V	
Digital Input Voltage (PDN, CAD1-0, SCL, SDA pins)	VIND	-0.3	DVDD+0.3	V	
Ambient Temperature (power applied)	Ta	-40	85	°C	
Storage Temperature	Tstg	-65	150	°C	

Note: 1. All voltages with respect to ground.

Note: 2. AVSS, VVSS1-3 and DVSS must be connected to the same analog ground plane.

WARNING: Operation at or beyond these limits may result in permanent damage to the device.
Normal operation is not guaranteed at these extremes.

RECOMMENDED OPERATING CONDITIONS

(AVSS = VVSS1-3 = DVSS = 0V; Note: 1)

Parameter	Symbol	min	typ	max	Units	
Power Supplies (Note: 3)	Audio	AVDD	4.5	5.0	5.5	V
	Video (Note: 4)	VVDD1	4.5	5.0	5.5	V
	Video (Note: 4)	VVDD2	4.5	5.0	5.5	V
	Digital	DVDD	3.0	3.3	3.6	V
	VVDD1 – AVDD	ΔVDD1	-0.3	0	+0.3	V
	VVDD2 – AVDD	ΔVDD2	-0.3	0	+0.3	V

Note: 3. The power-up sequence between AVDD, VVDD1, VVDD2 and DVDD is not critical.

Note: 4. VVDD1 and VVDD2 must be the same voltage.

*AKM assumes no responsibility for the usage beyond the conditions in this datasheet.

ANALOG CHARACTERISTICS (AUDIO)

(Ta=25°C; AVDD = VVDD1-2 = 5V, DVDD = 3.3V; AVSS = VVSS1-3 = DVSS = 0V; Signal Frequency=1kHz, Measurement Frequency=20Hz~20kHz, unless otherwise specified)

Parameter		min	typ	max	Units
S/(N+D)	Input=0dBV	82	92		dB
DR (0dBV)	Input=-60dBV, A-weighted	88	96		dB
S/N (0dBV)	Input=0ff, A-weighted	88	96		dB
Input Impedance	(Note: 5)	20			kΩ
Maximum Input Voltage	(Note: 6)	1	-	-	Vrms
Gain		-0.5	0	0.5	dB
Interchannel Isolation	(Note: 7)	-	100		dB
Interchannel Gain Mismatch			0.2	-	dB
Gain Drift			20	-	ppm/°C
Load Resistance	(Note: 8) R1+R2 (Figure 4)	5			kΩ
Load Capacitance	C1 (Figure 4)			400	pF
	C2 (Figure 4)			30	pF
Power Supply Rejection	(Note: 9)	-	50		dB
Input Detection Circuit					
Input Reception	1kHz (Note: 10)	-43	-31	-26	dBV
Input Reception Adjustment Gain Step	(Note: 11)	-	3	-	dB

Note: 5. Connected GND1-7 to GND using a capacitor for AC-coupling.

Note: 6. The Input Voltage meets S/(N+D)>82dB

Note: 7. Between all channels of LIN1-7 and RIN1-7.

Note: 8. The output resistance of audio output (LOUT1-3 and ROUT1-3) are less than 10Ω(typ).

Note: 9. Applied to AVDD, VVDD1-2 and DVDD with a sine wave (1kHz, 50mVpp).

Note: 10. Detect an instant value. 31dBV=+40mV0p. If the input voltage is smaller than the detection reception value, the signal isn't detected, and if the input voltage is larger than the detection reception value, the signal is detected.

The input reception value is proportional to AVDD voltage as of 0.008 x AVDD V0p(typ).

Note: 11. Input Reception Adjustment Gain is +6dB~-6dB.

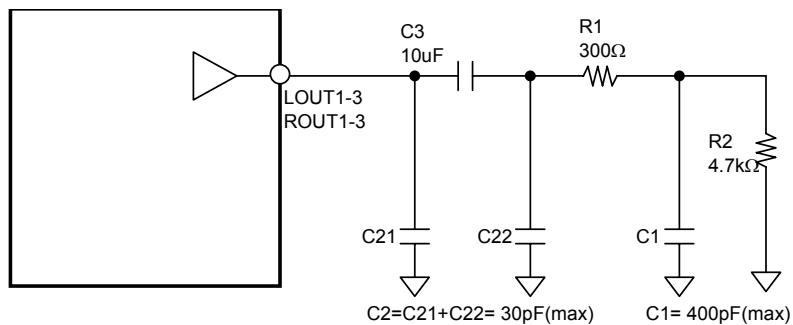

Figure 4. Load Resistance R1, R2 and Load Capacitance C1, C2.

ANALOG CHARACTERISTICS (VIDEO)

(Ta=25°C; AVDD = VVDD1-2 = 5V, DVDD =3.3V; AVSS = VVSS1-3 = DVSS = 0V; unless otherwise specified)

Parameter	Conditions	min	typ	max	Units
Sync Tip Clamp Voltage (Note: 12)	At output pin.	-	0.6	-	V
Gain (Note: 13)	Input=0.3Vp-p, 100kHz	5.5	6	6.5	dB
Frequency Response (Note: 13)	Input=0.3Vp-p, 100kHz to 6MHz.	-1.0		1.0	dB
Maximum Input Signal	f=100kHz, maximum with distortion < 1.0%, gain=6dB(typ).	1.5	-	-	Vpp
Load Resistance	R1+R2(Note: 14)	150	-	-	Ω
Load Capacitance	C1 (Note: 14) C2 (Note: 14)			400 15	pF pF
Interchannel Isolation (Note: 15)	f=4.43MHz, 1Vpp input.	-	50	-	dB
S/N	Reference Level = 0.7Vpp, CCIR 567 weighting. BW= 15kHz to 5MHz.	-	74	-	dB
Differential Gain	0.7Vpp 5steps modulated staircase. chrominance &burst are 280mVpp, 4.43MHz.	-	±0.4	-	%
Differential Phase	0.7Vpp 5steps modulated staircase. chrominance &burst are 280mVpp, 4.43MHz.	-	±0.9	-	Degree

Input Detection Circuit

Input Reception (Note: 16)		0.04	0.07	0.1	Vpp
----------------------------	--	------	------	-----	-----

Note: 12. SAGN bit="1", DC output. There is no specification for using the Sag Compensation circuit (SAGN bit="0").

Sync Tip Clamp Voltage is proportional to AVDD voltage, VOUT=0.17 x AVDD V(typ).

Note: 13. If SAGN bit="0" for using the Sag Compensation circuit, the measurement point is between C3 and R1 of Figure 5. If SAGN bit="1" for DC output, the measurement point is video output pin.

Note: 14. See Figure 5 and Figure 6.

Note: 15. Between all channels of VIN1-6.

Note: 16. If the input voltage is smaller than the detection reception value, the signal isn't detected. If the input voltage is larger than the detection reception value, the signal is detected. The input reception value is proportional to AVDD voltage, 0.014 x AVDD Vpp(typ).

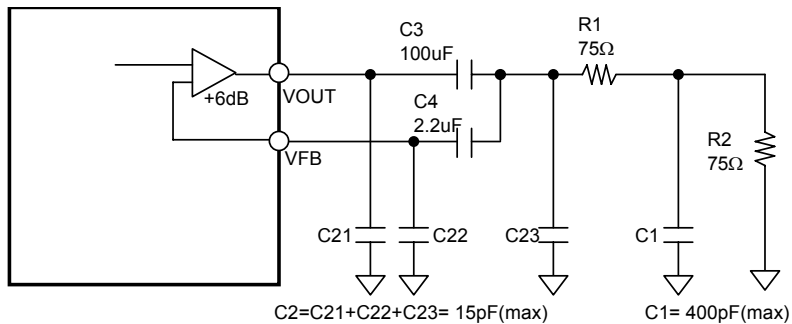

Figure 5. Load Resistance R1, R2 and Load Capacitance C1, C2 (SAGN bit="0", using the Sag Compensation circuit)

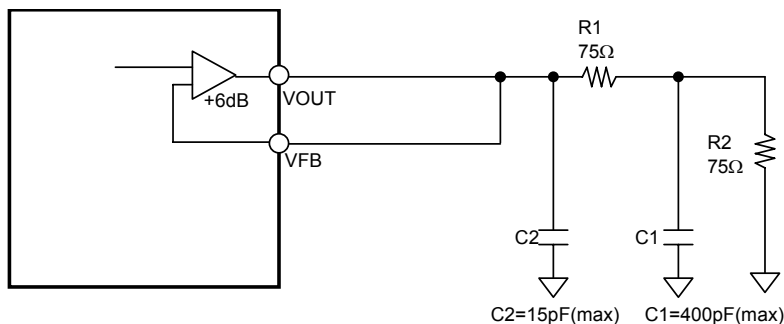

Figure 6. Load Resistance R1, R2 and Load Capacitance C1, C2 (SAGN bit="1", DC output)

DC CHARACTERISTICS

(Ta=-40~85°C; AVDD = VVDD1-2 = 4.5~5.5V, DVDD =3.0~3.6V)

Parameter	Symbol	min	typ	max	Units
High-Level Input Voltage (PDN, SCL,SDA,CAD0-1,TEST,IICN pins)	VIH	70%DVDD	-	-	V
Low-Level Input Voltage (PDN, SCL,SDA,CAD0-1,TEST,IICN pins)	VIL	-	-	30%DVDD	V
High-Level Output Voltage (Iout=-400μA)	VOH	DVDD-0.4	-	-	V
Low-Level Output Voltage (CDTO pin: Iout=400μA)	VOL	-	-	0.4	V
(Q0-4, INT pins: Iout=1mA)	VOL	-	-	0.4	V
(SDA pin: Iout=3mA)	VOL	-	-	0.4	V
Input Leakage Current	Iin	-	-	±10	μA

Parameter	min	typ	max	Units
Power Supplies				
Power Supply Current				
Normal Operation (PDN pin = "H") (Note: 17)				
AVDD		18	27	mA
VVDD1+VVDD2 (Note: 18)		18	27	mA
DVDD		1	2	mA
Power-down mode (PDN pin = "L") (Note: 19)				
AVDD		10		μA
VVDD1+VVDD2		10		μA
DVDD		10		μA
Total		30	50	μA

Note: 17. No input and no load.

Note: 18. If the output is DC output (SAGN bit = "1"), the current corresponded to the load resistance is added to no load current (typ. 18mA).

Note: 19. All analog input pins are no input, and all digital input pins are fixed to DVSS.

SWITCHING CHARACTERISTICS

(Ta= -40~85°C; AVDD = VVDD1-2 = 4.5~5.5V, DVDD= 3.0~3.6V, CL= 20pF)

Control Interface Timing (I²C Bus, Note: 20)					
SCL Clock Frequency	fSCL	-		400	kHz
Bus Free Time Between Transmissions	tBUF	1.3		-	μs
Start Condition Hold Time (prior to first clock pulse)	tHD:STA	0.6		-	μs
Clock Low Time	tLOW	1.3		-	μs
Clock High Time	tHIGH	0.6		-	μs
Setup Time for Repeated Start Condition	tSU:STA	0.6		-	μs
SDA Hold Time from SCL Falling (Note: 21)	tHD:DAT	0		-	μs
SDA Setup Time from SCL Rising	tSU:DAT	0.1		-	μs
Rise Time of Both SDA and SCL Lines	tR	-		0.3	μs
Fall Time of Both SDA and SCL Lines	tF	-		0.3	μs
Setup Time for Stop Condition	tSU:STO	0.6		-	μs
Pulse Width of Spike Noise Suppressed by Input Filter	tSP	0		50	ns
Capacitive load on bus	Cb	-		400	pF
Control Interface Timing (4-wire serial mode)					
CCLK Period	tCCK	200			ns
CCLK Pulse Width Low	tCCKL	80			ns
Pulse Width High	tCCKH	80			ns
CDTI Setup Time	tCDS	50			ns
CDTI Hold Time	tCDH	50			ns
CSN “H” Time	tCSW	150			ns
CSN “↓” to CCLK “↑”	tCSS	50			ns
CCLK “↑” to CSN “↑”	tCSH	50			ns
CDTO Delay	tDCD			45	ns
CSN “↑” to CDTO Hi-Z	tCCZ			70	ns
Power-down & Reset Timing					
PDN Pulse Width (Note: 21)	TPD	150			ns

Note: 20. I²C-bus is a trademark of NXP B.V.

Note: 21. Data must be held for sufficient time to bridge the 300 ns transition time of SCL.

Note: 22. The AK4220 should be reset by PDN pin = “L” upon power up.

■ Timing Diagram

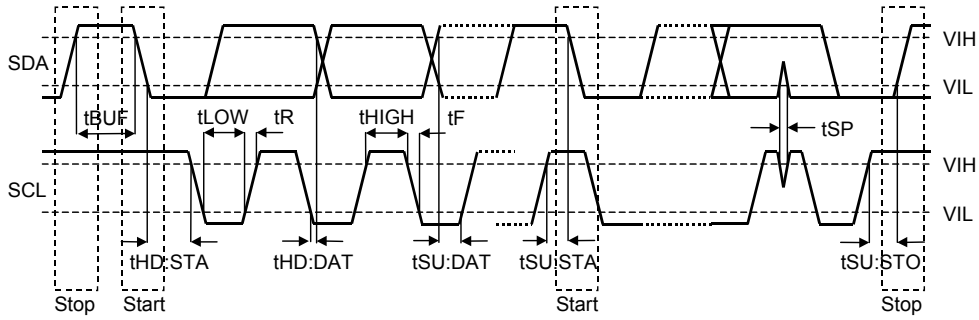

Figure 7. I²C Bus Mode Timing

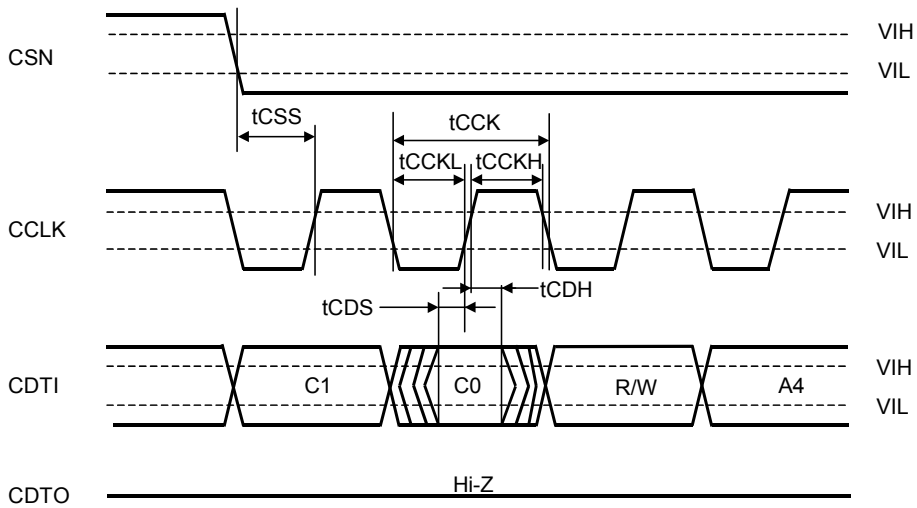

Figure 8. WRITE/READ Command Input Timing (4-wire serial mode)

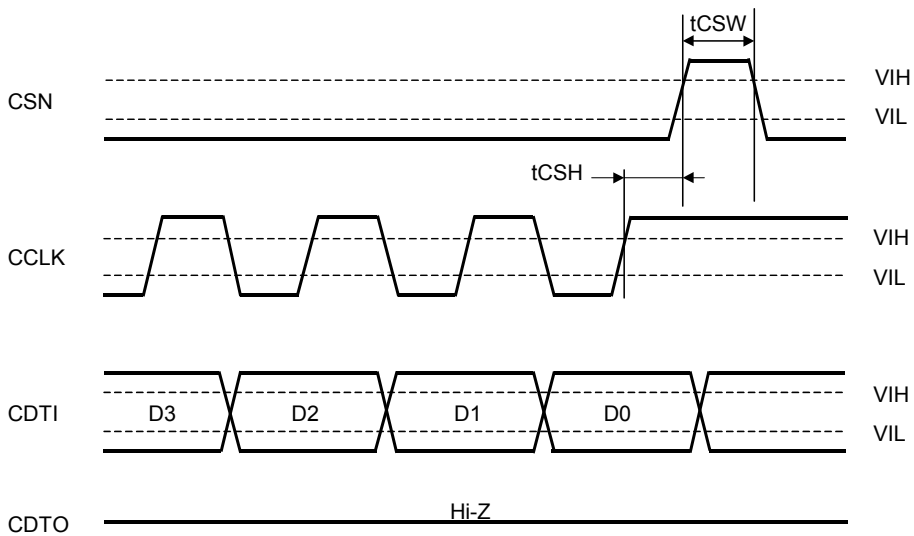

Figure 9. WRITE Data Input Timing (4-wire serial mode)

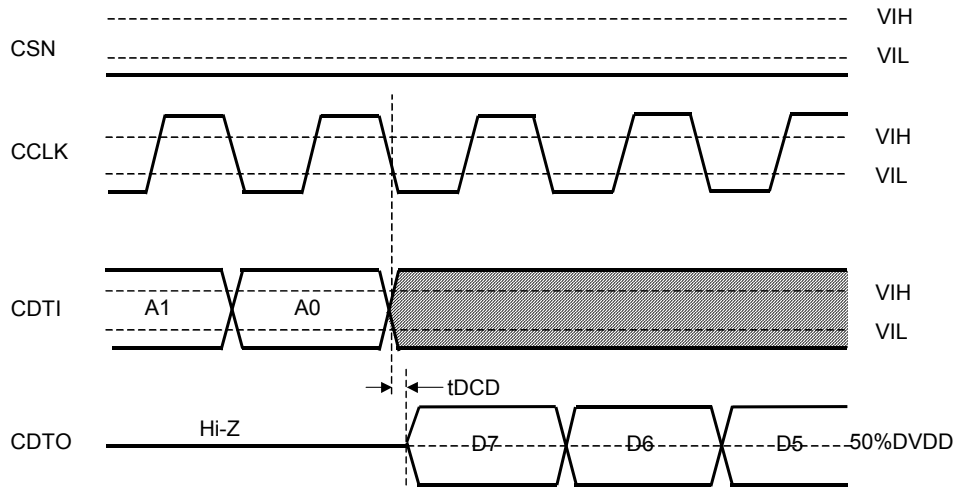

Figure 10. READ Data Output Timing1 (4-wire serial mode)

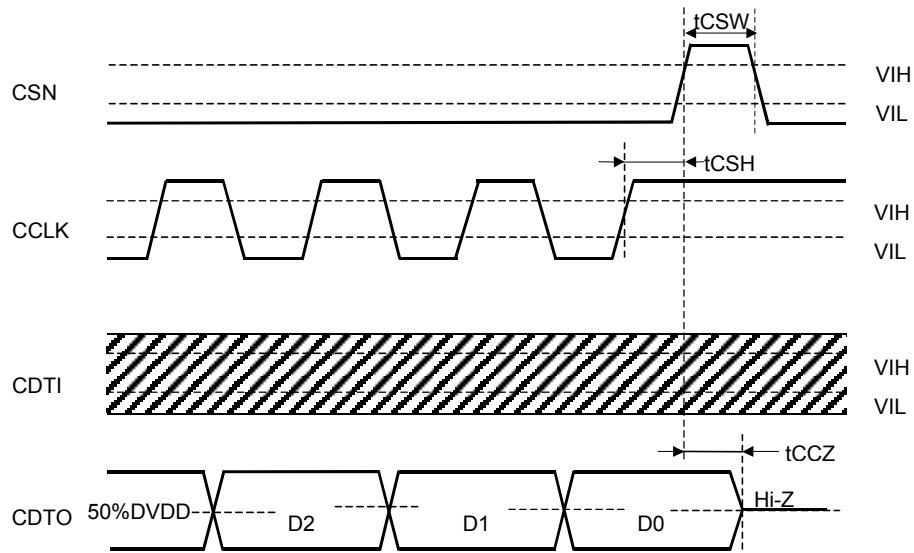

Figure 11. READ Data Output Timing2 (4-wire serial mode)

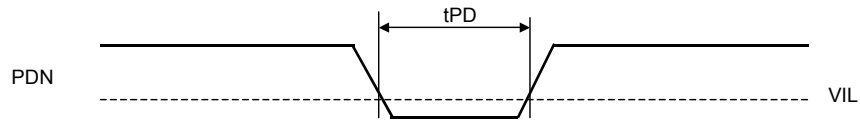

Figure 12. Power-down & Reset Timing

OPERATION OVERVIEW

■ Power-down options

The AK4220 should be reset once by bringing PDN pin = "L" upon power-up.

■ Audio Bias Control Circuit

The AK4220 has an on-chip audio bias voltage control circuit. Bringing BIAS bit to "1", the bias voltage (MUTET pin) smoothly set from AVSS to AVDD/2(typ) by 150ms (typ, [Note: 23](#)). The change of BIAS bit from "1" to "0" also makes smooth transient from AVDD/2(typ) to AVSS by 150ms (typ, [Note: 23](#)). This feature achieves pop noise free at power-on/off.

Note: 23. AVDD=5.0V, the capacitor of MUTET pin is C=1uF. The rise and fall times are proportional to the voltage of AVDD and the capacitor value of MUTET pin.

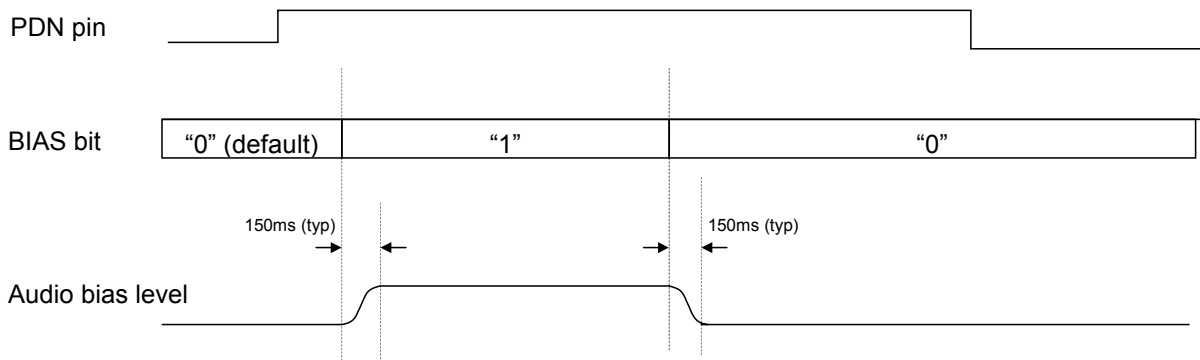

Figure 13. BIAS bit

■ Audio Signal Input, Video Signal Input

1. Audio Signal Input

The ground noise can be cancelled by the differential input with the same ground for L and R channel. The output of LIN and RIN are the same phase. LIN+1-7, RIN+1-7 and GND1-7 pins must be AC coupled using 0.47uF capacitor.

2. Video Signal Input

Tip Sync level is fixed by internal clamp circuit. VIN1-6 pins must be input through 0.47uF capacitor for AC coupling.

■ Input Selector

The AK4220 have 7:3 input selectors for audio input, and 6:3 input selectors for video input. The audio input selectors are set by ASEL12-10bits, ASEL22-20bits and ASEL32-30 bits, and the video input selectors are set by VSEL12-10bits, VSEL22-20bits and VSEL32-30 bits.

ASEL12 bit	ASEL11 bit	ASEL10 bit	Input Selector
0	0	0	Off (Note: 24)
0	0	1	LIN1 / RIN1
0	1	0	LIN2 / RIN2
0	1	1	LIN3 / RIN3
1	0	0	LIN4 / RIN4
1	0	1	LIN5 / RIN5
1	1	0	LIN6 / RIN6
1	1	1	LIN7 / RIN7

(default)

Table 1. Audio Input Selector 1 (LOUT1/ROUT1)

ASEL22 bit	ASEL21 bit	ASEL20 bit	Input Selector
0	0	0	Off (Note: 24)
0	0	1	LIN1 / RIN1
0	1	0	LIN2 / RIN2
0	1	1	LIN3 / RIN3
1	0	0	LIN4 / RIN4
1	0	1	LIN5 / RIN5
1	1	0	LIN6 / RIN6
1	1	1	LIN7 / RIN7

(default)

Table 2. Audio Input Selector 2 (LOUT2/ROUT2)

ASEL32 bit	ASEL31 bit	ASEL30 bit	Input Selector
0	0	0	Off (Note: 24)
0	0	1	LIN1 / RIN1
0	1	0	LIN2 / RIN2
0	1	1	LIN3 / RIN3
1	0	0	LIN4 / RIN4
1	0	1	LIN5 / RIN5
1	1	0	LIN6 / RIN6
1	1	1	LIN7 / RIN7

(default)

Table 3. Audio Input Selector 3 (LOUT3/ROUT3)

Note: 24. The audio outputs become common voltage (VCOM) when the input selectors are off. If BIAS bit = "0", the outputs become 0V.

VSEL12 bit	VSEL11 bit	VSEL10 bit	Input Selector
0	0	0	Off (Note: 25)
0	0	1	VIN1
0	1	0	VIN2
0	1	1	VIN3
1	0	0	VIN4
1	0	1	VIN5
1	1	0	VIN6
1	1	1	N/A

(default)

Table 4. Video Input Selector 1 (VOUT1)

VSEL22 bit	VSEL21 bit	VSEL20 bit	Input Selector
0	0	0	Off (Note: 25)
0	0	1	VIN1
0	1	0	VIN2
0	1	1	VIN3
1	0	0	VIN4
1	0	1	VIN5
1	1	0	VIN6
1	1	1	N/A

(default)

Table 5. Video Input Selector 2 (VOUT2)

VSEL32 bit	VSEL31 bit	VSEL30 bit	Input Selector
0	0	0	Off (Note: 25)
0	0	1	VIN1
0	1	0	VIN2
0	1	1	VIN3
1	0	0	VIN4
1	0	1	VIN5
1	1	0	VIN6
1	1	1	N/A

(default)

Table 6. Video Input Selector 3 (VOUT3)

Note: 25. The video outputs become Hi-Z when the input selectors are off.

■ Input Detection Circuit, INT pin Output

The AK4220 has channel-independent audio input detection circuit and video synchronization signal detection circuit. Each input source is set as shown in Table 7 and Table 8.

ADSEL2 bit	ADSEL1 bit	ADSEL0 bit	Detection Source
0	0	0	Off
0	0	1	LIN1 / RIN1
0	1	0	LIN2 / RIN2
0	1	1	LIN3 / RIN3
1	0	0	LIN4 / RIN4
1	0	1	LIN5 / RIN5
1	1	0	LIN6 / RIN6
1	1	1	LIN7 / RIN7

(default)

Table 7. Audio Input Detection Selector

VDSEL2 bit	VDSEL1 bit	VDSEL0 bit	Detection Source
0	0	0	Off
0	0	1	VIN1
0	1	0	VIN2
0	1	1	VIN3
1	0	0	VIN4
1	0	1	VIN5
1	1	0	VIN6
1	1	1	N/A

(default)

Table 8. Video Synchronization Signal Detection Selector

1. ADETL bit (Lch Audio Input Detection), ADETR bit (Rch Audio Input Detection)

The audio input detection circuit samples the input signal by accuracy of $100\text{kHz}\pm 30\%$.

If the signal over the detection reception value is detected consecutively more than the frequency set by ACT1-0 bits, ADETL-R bits become "1" and if the signal over the detection reception value isn't detected consecutively more than the frequency set by ACT1-0 bits during the time set by RTM1-0 bit, ADETL-R bits become "0".

The audio input detection for L/R channels is done independently. The input reception can be adjusted in the range of $\pm 6\text{dB}$ from $-31\text{dBV}(= +40\text{mV}_{\text{0p}})$ (typ) by LV2-0 bits. When writing to 05H(ADSEL2-0, ACT1-0, RTM1-0 bits), the counters for the consecutive detection frequency and recovery time are reset, and ADETL/R bits are reset to "0".

The setting of MADEL/R bit doesn't affect the operation of ADETL/R bit.

LV2 bit	LV1 bit	LV0 bit	Input Reception
0	0	0	-6dB
0	0	1	-3dB
0	1	0	0dB
0	1	1	+3dB
1	0	0	+6dB
1	0	1	N/A
1	1	0	N/A
1	1	1	N/A

(default)

0dB = +40mV_{0p}(typ)

Table 9. Level Setting of Audio Input Detection

ACT1 bit	ACT0 bit	Consecutive Detect Frequency
0	0	1
0	1	2
1	0	4
1	1	8

(default)

Table 10. Consecutive Detection frequency Setting of Audio Input Detection

RTM1 bit	RTM0 bit	Recovery Time (typ)
0	0	40ms
0	1	80ms
1	0	160ms
1	1	320ms

(default)

Table 11. Recovery Time Setting of Audio Input Detection

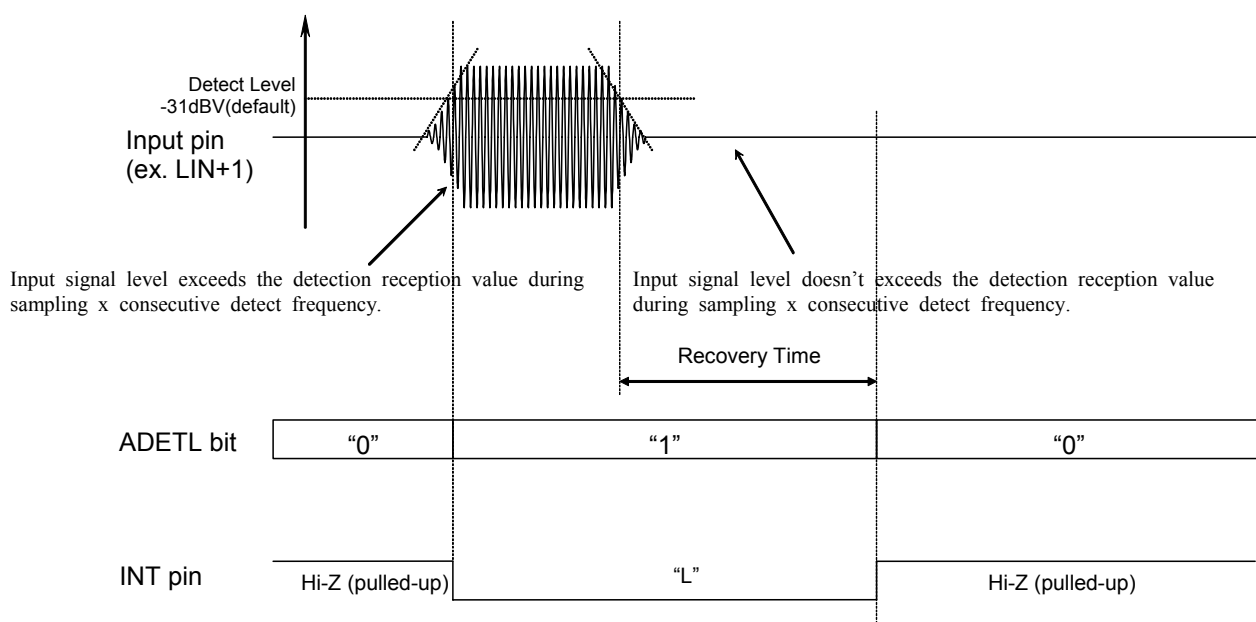

Figure 14. Audio Detection Operation

2. VDET bit (Video Sync Signal Detection)

The video sync signal detection circuit can change the detection mode by VDMD bit.

VDMD bit = "0" (default)

When video sync signal above 0.07Vpp(typ) is detected, VDET bit become "1" and VDET bit returns to "0" after reading the register of 08H. The VDET bit is also reset to "0" by writing to the register of 04H with VDSEL2-0 bits.

VDMD bit = "1"

The detection circuit counts the number of video sync signal above 0.07Vpp(typ) every 40ms(±30%) period generated by the internal counter. When the period with the sync of 384 or more continues tow times, the VDET bit becomes "1" after 1/2 period. When the period with the sync signal less than 384 continues tow times, the VDET bit becomes "0" after 1/2 period.

The internal timer isn't reset when changing the input source. Therefore the detection time, from after changing the input source to VDET bit = "1", depends on the timing of input source change.

In case of a period that the internal timer count is the shortest(40ms x 70% = 28ms), when the detection circuit counts 384 times during the first period that receives video sync signal and counts 384 times or more in the following period, the detection time becomes the shortest.

$$\text{Detection time (min)} = (1/fH) \times 384 + 28\text{ms} \times 1.5 \cong 66.6\text{ms} @ fH=15.625\text{kHz}$$

fH: frequency of video synchronization signal

If a period that internal timer counts is the longest (40ms x 130% = 52ms), when the detection circuit counts only 383 times during the first period that receives video sync signal and counts 384 times or more in the following two periods, the detection time becomes the longest.

$$\text{Detection time (max)} = (1/fH) \times 384 + 52\text{ms} \times 2.5 \cong 154.5\text{ms} @ fH=15.625\text{kHz}$$

fH: frequency of video synchronization signal

When writing to 04H(VDSEL2-0bits), the internal timer is reset and VDET bit becomes "0".

The setting of MVDET bit doesn't affect the operation of VDET bit.

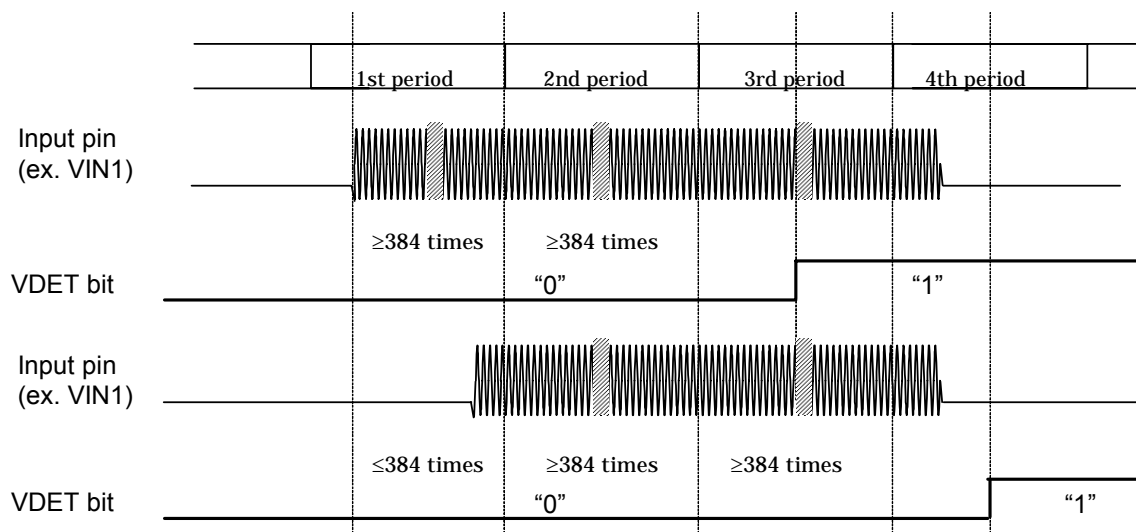

Figure 15. VDET bit timing (VDMD bit = "1")

3. INT pin output

The output source of INT pin is ORed between ADETL/R bits and VDET bit. If the output source of INT pin is “H”, INT pin=“L”, and if the output source of INT pin is “L”, INT pin=“Hi-Z”. If each mask bit is “1”, each detection bit is masked independently and the detection result isn’t reflected to INT pin.

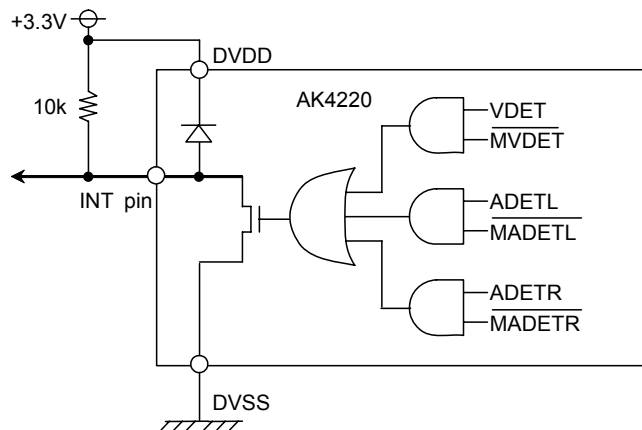

Figure 16. INT Pin Output

MVDET bit	MADETL bit	MADETR bit	INT pin output source
0	0	0	“OR” (VDET bit, ADETL bit, ADETR bit) (default)
0	0	1	“OR” (VDET bit, ADETL bit)
0	1	0	“OR” (VDET bit, ADETR bit)
0	1	1	VDET bit
1	0	0	“OR” (ADETL bit, ADETR bit)
1	0	1	ADETL bit
1	1	0	ADETR bit
1	1	1	“L”(INT pin = “Hi-Z”)

Table 12. INT Pin Output Setting

■ Parallel Output Circuit, INT Output Circuit, SDA Output Circuit

Q0-4 bits setting are output from Q0-4 pins. Each output is open drain. Normally connected to DVSS with a 10kohm resistance. INT pin is the same output circuit (Refer Figure 16).

SDA pin is open drain output, and connected to DVSS with a resistance. Refer to I²C bus standard as for resistance value.

As there is a protection between each pin and DVDD, the pulled-up voltage should be DVDD or lower. And if the pulled-up voltage is supplied from the different power supply from DVDD, only DVDD should not be powered off independently. When PDN pin =“L” and DVDD is supplied to the AK4220, the AK4220 can be in power-down state. In Power-down state, VVDD1-2 and AVDD can be powered off.

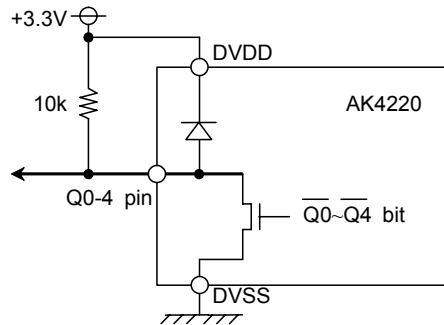

Figure 17. Q0-Q4 Pin Output

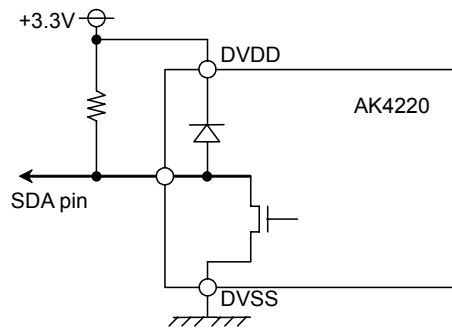

Figure 18. SDA Pin Output

■ Serial Control Interface

1. 4 wire serial control mode (IICN pin = “H”)

With the 4-wire μ P interface pins (CSN, CCLK, CDTI and CDTO), the data on this interface consists of the Chip address (2-bits, Fixed to “00”), Read/Write (1-bit), Register address (MSB first, 5-bits) and Control data (MSB first, 8-bits). The data are clocked in on the rising edge of CCLK, and data are clocked out on the falling edge of CCLK. For write operations, the data is latched after a low-to-high transition of the 16th CCLK. For read operation, the data is outputted to Hi-Z on the rising edge of CSN. The clock speed of CCLK is 5MHz(max). The value of the internal registers is initialized at PDN pin = “L”.

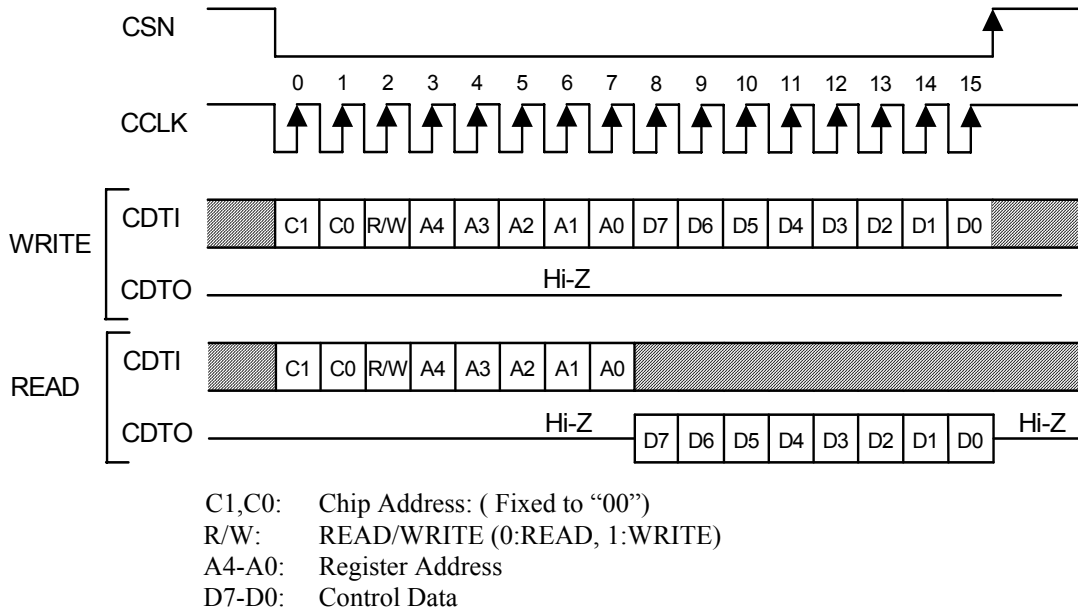

Figure 19. 4-wrie Serial Control I/F Timing

2. I²C bus control mode (IICN pin = "L")

The AK4220 supports the fast-mode I²C-bus system (max: 400kHz).

1. WRITE Operations

Figure 20 shows the data transfer sequence for the I²C-bus mode. All commands are preceded by a START condition. A HIGH to LOW transition on the SDA line while SCL is HIGH indicates a START condition (Figure 26). After the START condition, a slave address is sent. This address is 7 bits long followed by the eighth bit that is a data direction bit (R/W). The most significant five bits of the slave address are fixed as "00100". The next one bit is CAD0 (device address bit). This bit identifies the specific device on the bus. The hard-wired input pin (CAD0 pin) set these device address bits (Figure 21). If the slave address matches that of the AK4220, the AK4220 generates an acknowledge and the operation is executed. The master must generate the acknowledge-related clock pulse and release the SDA line (HIGH) during the acknowledge clock pulse (Figure 27). A R/W bit value of "1" indicates that the read operation is to be executed. A "0" indicates that the write operation is to be executed.

The second byte consists of the control register address of the AK4220. The format is MSB first, and those most significant 4-bits are fixed to zeros (Figure 22). The data after the second byte contains control data. The format is MSB first, 8bits (Figure 23). The AK4220 generates an acknowledge after each byte has been received. A data transfer is always terminated by a STOP condition generated by the master. A LOW to HIGH transition on the SDA line while SCL is HIGH defines a STOP condition (Figure 26).

The AK4220 can perform more than one byte write operation per sequence. After receipt of the third byte the AK4220 generates an acknowledge and awaits the next data. The master can transmit more than one byte instead of terminating the write cycle after the first data byte is transferred. After receiving each data packet the internal 5-bit address counter is incremented by one, and the next data is automatically taken into the next address. If the address exceeds 08H prior to generating the stop condition, the address counter will "roll over" to 00H and the previous data will be overwritten.

The data on the SDA line must remain stable during the HIGH period of the clock. The HIGH or LOW state of the data line can only change when the clock signal on the SCL line is LOW (Figure 28) except for the START and STOP conditions.

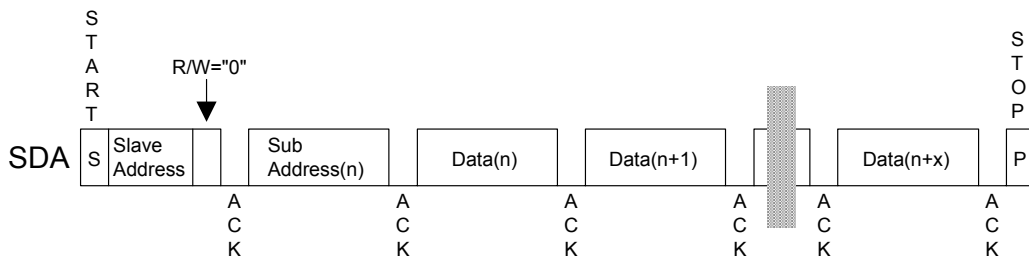

Figure 20. Data Transfer Sequence at the I²C-Bus Mode

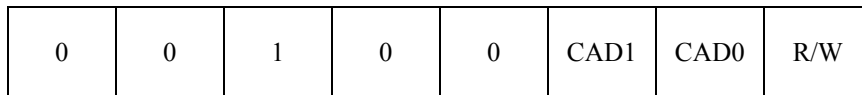

Figure 21. The First Byte

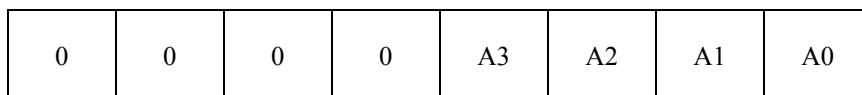

Figure 22. The Second Byte

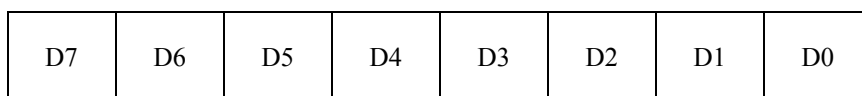

Figure 23. Byte Structure after the second byte

2. READ Operations

Set the R/W bit = "1" for the READ operation of the AK4220. After transmission of data, the master can read the next address's data by generating an acknowledge instead of terminating the write cycle after the receipt of the first data word. After receiving each data packet the internal 5-bit address counter is incremented by one, and the next data is automatically taken into the next address. If the address exceeds 09H prior to generating a stop condition, the address counter will "roll over" to 00H and the previous data will be overwritten.

The AK4220 supports two basic read operations: CURRENT ADDRESS READ and RANDOM ADDRESS READ.

2-1. CURRENT ADDRESS READ

The AK4220 contains an internal address counter that maintains the address of the last word accessed, incremented by one. Therefore, if the last access (either a read or write) were to address n, the next CURRENT READ operation would access data from the address n+1. After receipt of the slave address with R/W bit set to "1", the AK4220 generates an acknowledge, transmits 1-byte of data to the address set by the internal address counter and increments the internal address counter by 1. If the master does not generate an acknowledge to the data but instead generates a stop condition, the AK4220 ceases transmission.

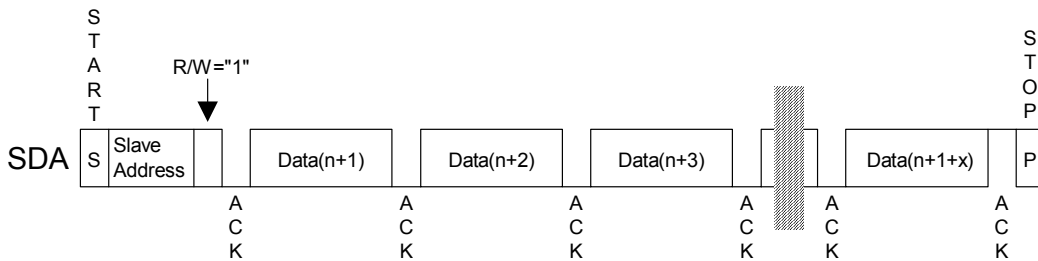

Figure 24. CURRENT ADDRESS READ

2-2. RANDOM ADDRESS READ

The random read operation allows the master to access any memory location at random. Prior to issuing the slave address with the R/W bit set to "1", the master must first perform a "dummy" write operation. The master issues a start request, a slave address (R/W bit = "0") and then the register address to read. After the register address is acknowledged, the master immediately reissues the start request and the slave address with the R/W bit set to "1". The AK4220 then generates an acknowledge, 1 byte of data and increments the internal address counter by 1. If the master does not generate an acknowledge to the data but instead generates a stop condition, the AK4220 ceases transmission.

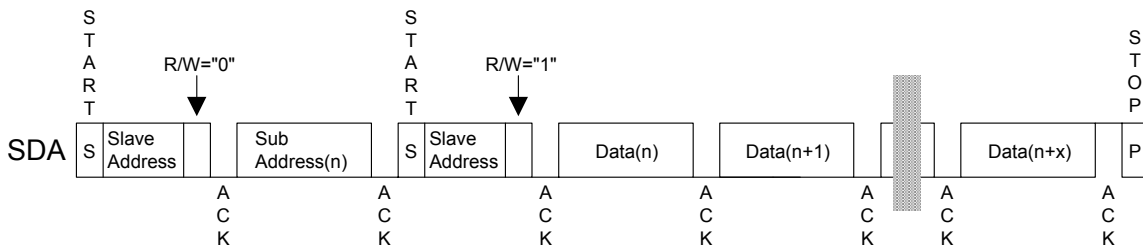

Figure 25. RANDOM ADDRESS READ

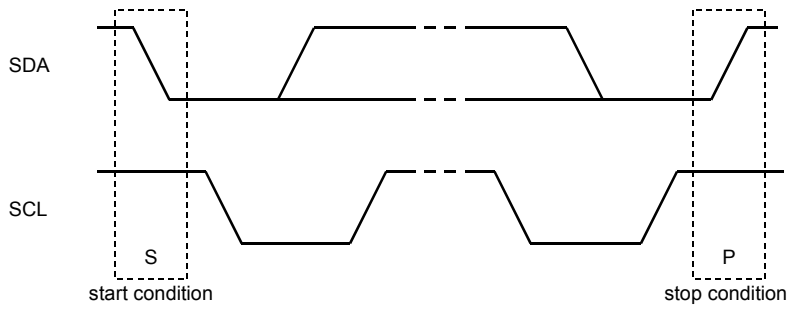

Figure 26. START and STOP Conditions

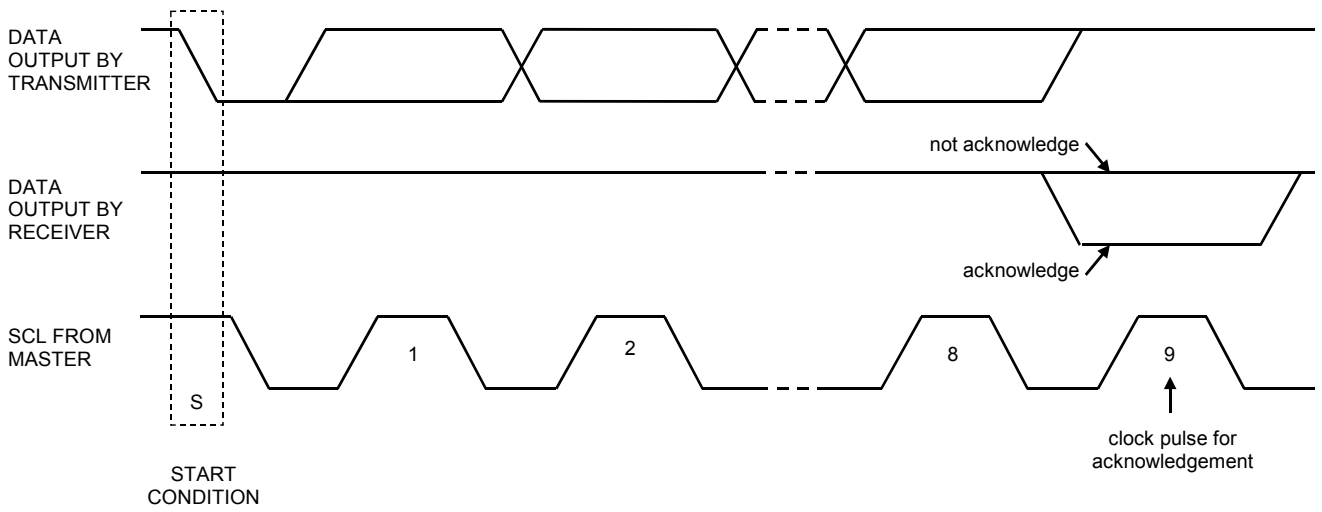

Figure 27. Acknowledge on the I²C-Bus

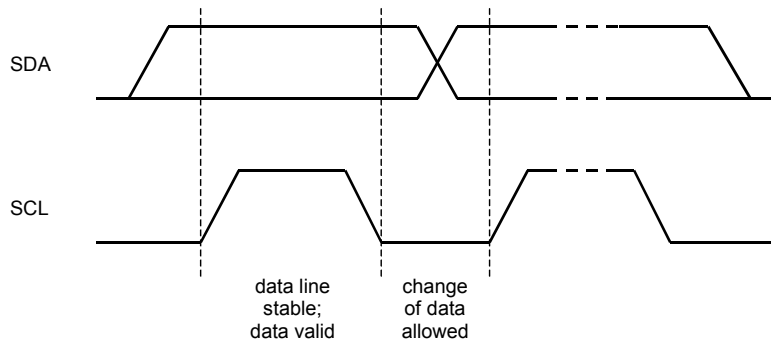

Figure 28. Bit Transfer on the I²C-Bus

■ Register Map

Addr	Register Name	D7	D6	D5	D4	D3	D2	D1	D0
00H	Power Down & Reset	0	0	0	SAGN	0	0	BIAS	PW
01H	Input Selector 1	0	VSEL12	VSEL11	VSEL10	0	ASEL12	ASEL11	ASEL10
02H	Input Selector 2	0	VSEL22	VSEL21	VSEL20	0	ASEL22	ASEL21	ASEL20
03H	Input Selector 3	0	VSEL32	VSEL31	VSEL30	0	ASEL32	ASEL31	ASEL30
04H	Detection Control1	0	VDSEL2	VDSEL1	VDSEL0	0	0	0	0
05H	Detection Control2	RTM1	RTM0	ACT1	ACT0	0	ADSEL2	ADSEL1	ADSEL0
06H	Detection Control3	VDMD	MVDET	MADETR	MADETL	0	LV2	LV1	LV0
07H	Parallel Output	0	0	0	Q4	Q3	Q2	Q1	Q0
08H	AV Detection	0	VDET	ADETR	ADETL	0	0	0	0

Note:

When the PDN pin goes “L”, the registers are initialized to their default values.

The bits indicated to “0” in the register map must contain a “0” value.

Do not write any data to the register over 09H.

■ Register Definitions

Reset & Initialize

Addr	Register Name	D7	D6	D5	D4	D3	D2	D1	D0
00H	Power Down & Reset	0	0	0	SAGN	0	0	BIAS	PW
	R/W	R/W	R/W	R/W	R/W	R/W	R/W	R/W	R/W
	Default	0	0	0	0	0	0	0	1

PW: Power bit

0: Power-down except register control block. The register don't change. (default)

1: Normal operation

When PDN pin="L", PW bit becomes "1" and the registers are initialized to their default values.

BIAS: Audio Bias Power bit

0: Power-down the Audio Bias Circuit (default)

1: Normal operation

SAGN: Video output selector bit

0: Sag Compensation mode (default)

1: DC output mode

Addr	Register Name	D7	D6	D5	D4	D3	D2	D1	D0
01H	Input Selector 1	0	VSEL12	VSEL11	VSEL10	0	ASEL12	ASEL11	ASEL10
	R/W	R/W	R/W	R/W	R/W	R/W	R/W	R/W	R/W
	Default	0	0	0	0	0	0	0	0

ASEL12-10: Audio Input Selector 1

Refer [Table 1](#)

VSEL12-10: Video Input Selector 1

Refer [Table 4](#)

Addr	Register Name	D7	D6	D5	D4	D3	D2	D1	D0
02H	Input Selector 2	0	VSEL22	VSEL21	VSEL20	0	ASEL22	ASEL21	ASEL20
	R/W	R/W	R/W	R/W	R/W	R/W	R/W	R/W	R/W
	Default	0	0	0	0	0	0	0	0

ASEL22-20: Audio Input Selector 2
Refer [Table 2](#)

VSEL22-20: Video Input Selector 2
Refer [Table 5](#)

Addr	Register Name	D7	D6	D5	D4	D3	D2	D1	D0
03H	Input Selector 3	0	VSEL32	VSEL31	VSEL30	0	ASEL32	ASEL31	ASEL30
	R/W	R/W	R/W	R/W	R/W	R/W	R/W	R/W	R/W
	Default	0	0	0	0	0	0	0	0

ASEL32-30: Audio Input Selector 3
Refer [Table 3](#)

VSEL32-30: Video Input Selector 3
Refer [Table 6](#)

Addr	Register Name	D7	D6	D5	D4	D3	D2	D1	D0
04H	Detection Control1	0	VDSEL2	VDSEL1	VDSEL0	0	0	0	0
	R/W	R/W	R/W	R/W	R/W	R/W	R/W	R/W	R/W
	Default	0	0	0	0	0	0	0	0

VDSEL2-0: Video Synchronization Signal Detection Selector
Refer [Table 8](#)

Addr	Register Name	D7	D6	D5	D4	D3	D2	D1	D0
05H	Detection Control2	RTM1	RTM0	ACT1	ACT0	0	ADSEL2	ADSEL1	ADSEL0
	R/W	R/W	R/W	R/W	R/W	R/W	R/W	R/W	R/W
	Default	0	1	0	0	0	0	0	0

ADSEL2-0: Audio Input Detection Selector
Refer [Table 7](#)

ACT1-0: Audio Input Continuous Detection times Setting
Refer [Table 10](#)

RTM1-0: Audio Input Detection Recovery time Setting
Refer [Table 11](#)

Addr	Register Name	D7	D6	D5	D4	D3	D2	D1	D0
06H	Detection Control3	VDMD	MVDET	MADETR	MADETL	0	LV2	LV1	LV0
	R/W	R/W	R/W	R/W	R/W	R/W	R/W	R/W	R/W
	Default	0	0	0	0	0	0	1	0

LV2-0: Audio Input Detection Level Setting

Refer [Table 9](#)

MADETL/R: Audio Input Detection Mask Setting for Lch/Rch

Refer [Table 12](#)

MVDET: Video Synchronization Signal Detection Mask Setting

Refer [Table 12](#)

VDMD: Video Synchronization Signal Detection Mode Setting

“0”: If video signal above 0.07Vpp(typ) is detected VDET bit becomes “1” and when reading 08H VDET bit becomes “0”. (default)

“1”: Refer VDET bit (Video Synchronization Signal Detection) section (Page19).

Addr	Register Name	D7	D6	D5	D4	D3	D2	D1	D0
07H	Parallel Output	0	0	0	Q4	Q3	Q2	Q1	Q0
	R/W	R/W	R/W	R/W	R/W	R/W	R/W	R/W	R/W
	Default	0	0	0	1	1	1	1	1

Q4-0: Parallel Output Setting

“1”: Hi-Z(default)

“0”: “L” Output

Addr	Register Name	D7	D6	D5	D4	D3	D2	D1	D0
08H	AV Detection	0	VDET	ADETR	ADETL	0	0	0	0
	R/W	READ	READ	READ	READ	READ	READ	READ	READ
	Default	0	0	0	0	0	0	0	0

ADETL/R: Audio Input Detection States for Lch/Rch

“0”: Undetected (default)

“1”: Detected

VDET: Video Synchronization Signal Detection States

“0”: Undetected (default)

“1”: Detected

Writing to address 08H will be ignored.

SYSTEM DESIGN

Figure 29 shows the system connection diagram. An evaluation board [AKD4220] is available which demonstrates the optimum layout, power supply arrangements and measurement results.

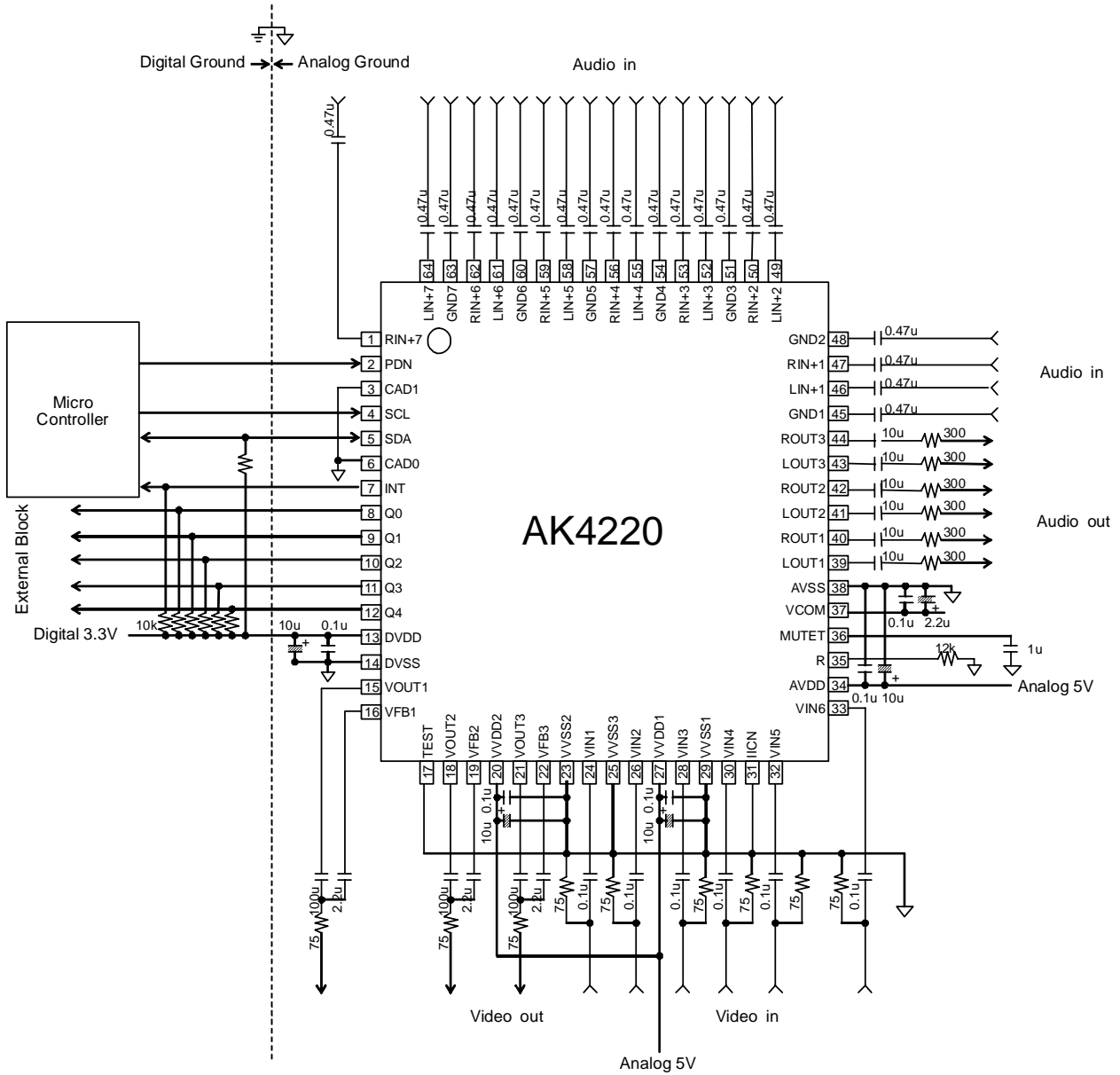

Figure 29. Typical Connection Diagram

1. Grounding and Power Supply Decoupling

The AK4220 requires careful attention to power supply and grounding arrangements. AVDD, VVDD1-2 and DVDD are usually supplied from the analog power supply in the system. Alternatively if AVDD, VVDD1-2 and DVDD are supplied separately, the power up sequence is not critical. AVSS, VVSS1-3 and DVSS must be connected to the analog ground plane. System analog ground and digital ground should be connected together near to where the supplies are brought onto the printed circuit board. Decoupling capacitors should be as close to the AK4220 as possible, with the small value ceramic capacitors being the nearest.

2. Voltage Reference

VCOM is a signal ground of this chip. A 2.2 μ F electrolytic capacitor in parallel with a 0.1 μ F ceramic capacitor attached between VCOM and AVSS eliminates the effects of high frequency noise. No load current may be drawn from VCOM pin. All signals, especially clocks, should be kept away from VCOM in order to avoid unwanted coupling into the AK4220. MUTET is an audio output common voltage. A 0.1 μ F electrolytic capacitor attached between VCOM and AVSS. No load current may be drawn from MUTET. All signals, especially clocks, should be kept away from MUTET in order to avoid unwanted coupling into the AK4220.

3. The notes for drawing the board

Analog input and output pins should be as short as possible in order to avoid unwanted coupling into the AK4220. The unused pins should be open.

4. Video Output

The AK4220 has on-chip 3ch video amp for drive 150 Ω resistance and two way to output video signal. One way is using the Sag Compensation circuit (Figure 30), the other way is using DC output (Figure 31). 100 μ F and 2.2 μ F capacitors is needed for Sag Compensation circuit. It should be shorted VOUT pin and VFB pin using DC output mode. The clamp level is 600mV(typ) in the DC output mode. Each output way can set by SAGN bit (Table 13).

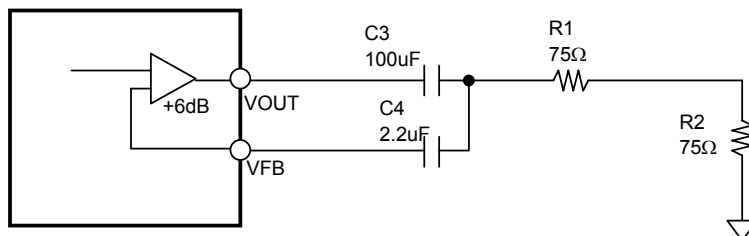

Figure 30. Video Block (SAGN bit="0", Sag Compensation mode)

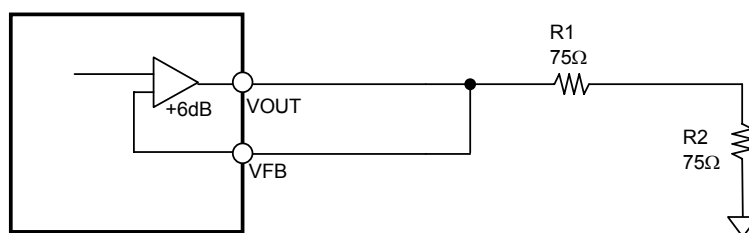

Figure 31. Video Block (SAGN bit="1", DC Output)

SAGN bit	Output	
0	Sag Compensation mode	(default)
1	DC output mode	

Table 13. Setting for the video output

PACKAGE

64pin LQFP (Unit: mm)

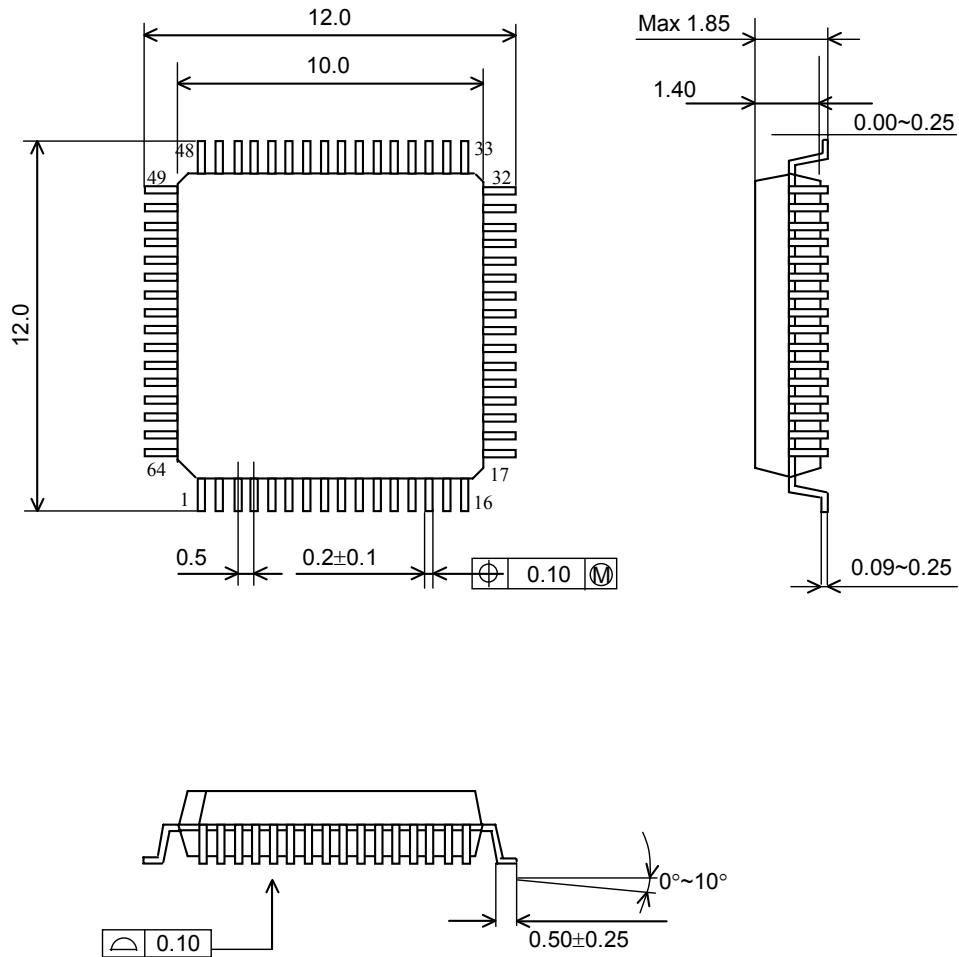

■ Package & Lead frame material

- Package molding compound: Epoxy
- Lead frame material: Cu
- Lead frame surface treatment: Solder (Pb free) plate

MARKING

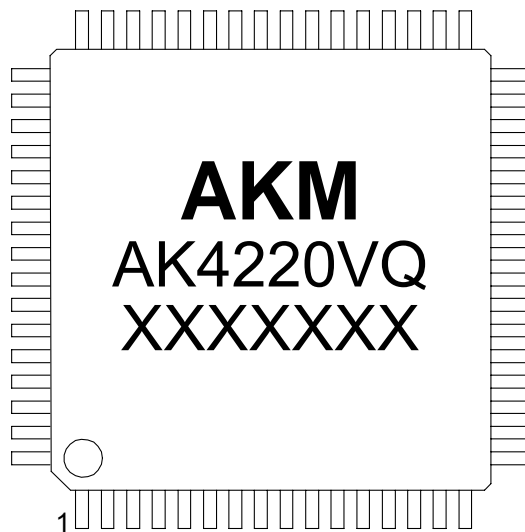

- 1) Pin #1 indication
- 2) Asahi Kasei Logo
- 3) Marking Code: AK4220VQ
- 4) Date Code: XXXXXXX (7 digits)

REVISION HISTORY

Date (YY/MM/DD)	Revision	Reason	Page	Contents
07/05/10	00	First Edition		
10/09/28	01	Error Correction	19	2. VDER bit The description was changed.
			23	2. I2C bus control mode 1. WRITE Operation "001000" → "00100" most significant 3-bits → 4-bits
		Specification Change	31	PACKAGE The package dimensions were changed.

IMPORTANT NOTICE

- These products and their specifications are subject to change without notice.
When you consider any use or application of these products, please make inquiries the sales office of Asahi Kasei Microdevices Corporation (AKM) or authorized distributors as to current status of the products.
- Descriptions of external circuits, application circuits, software and other related information contained in this document are provided only to illustrate the operation and application examples of the semiconductor products. You are fully responsible for the incorporation of these external circuits, application circuits, software and other related information in the design of your equipments. AKM assumes no responsibility for any losses incurred by you or third parties arising from the use of these information herein. AKM assumes no liability for infringement of any patent, intellectual property, or other rights in the application or use of such information contained herein.
- Any export of these products, or devices or systems containing them, may require an export license or other official approval under the law and regulations of the country of export pertaining to customs and tariffs, currency exchange, or strategic materials.
- AKM products are neither intended nor authorized for use as critical components^{Note1)} in any safety, life support, or other hazard related device or system^{Note2)}, and AKM assumes no responsibility for such use, except for the use approved with the express written consent by Representative Director of AKM. As used here:
 - Note1) A critical component is one whose failure to function or perform may reasonably be expected to result, whether directly or indirectly, in the loss of the safety or effectiveness of the device or system containing it, and which must therefore meet very high standards of performance and reliability.
 - Note2) A hazard related device or system is one designed or intended for life support or maintenance of safety or for applications in medicine, aerospace, nuclear energy, or other fields, in which its failure to function or perform may reasonably be expected to result in loss of life or in significant injury or damage to person or property.
- It is the responsibility of the buyer or distributor of AKM products, who distributes, disposes of, or otherwise places the product with a third party, to notify such third party in advance of the above content and conditions, and the buyer or distributor agrees to assume any and all responsibility and liability for and hold AKM harmless from any and all claims arising from the use of said product in the absence of such notification.