

# AK4359

## 106dB 192kHz 24-Bit 8ch DAC

GENERAL DESCRIPTION

The AK4359 is eight channels 24bit DAC corresponding to digital audio system. Using AKM's advanced multi bit architecture for its modulator the AK4359 delivers a wide dynamic range while preserving linearity for improved THD+N performance. The AK4359 has single end SCF outputs, increasing performance for systems with excessive clock jitter. The AK4359 accepts 192kHz PCM data, ideal for a wide range of applications including DVD-Audio.

FEATURES

- Sampling Rate Ranging from 8kHz to 192kHz
- 24Bit 8 times Digital Filter with Slow roll-off option
- THD+N: -94dB
- DR, S/N: 106dB
- High Tolerance to Clock Jitter
- Single Ended Output Buffer with 2nd order Analog LPF
- Digital De-emphasis for 32, 44.1 & 48kHz sampling
- Zero Detect function
- Channel Independent Digital Attenuator (Linear 256 steps)
- 3-wire Serial and I<sup>2</sup>C Bus  $\mu$ P I/F for mode setting
- I/F format: MSB justified, LSB justified (16bit, 20bit, 24bit), I<sup>2</sup>S, TDM
- Master clock: 256fs, 384fs, 512fs or 768fs or 1152fs (Normal Speed Mode)  
128fs, 192fs, 256fs or 384fs (Double Speed Mode)  
128fs or 192fs (Quad Speed Mode)
- Power Supply: 4.5 to 5.5V
- 30pin VSOP Package

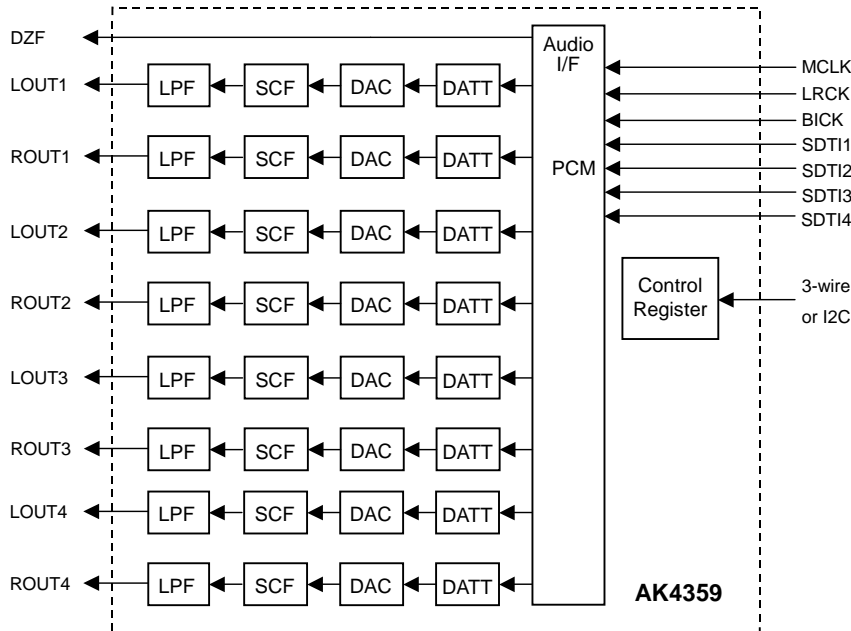

■ Ordering Guide

AK4359VF  
AKD4359

-40 ~ +85°C      30pin VSOP  
Evaluation Board for AK4359

■ Pin Layout

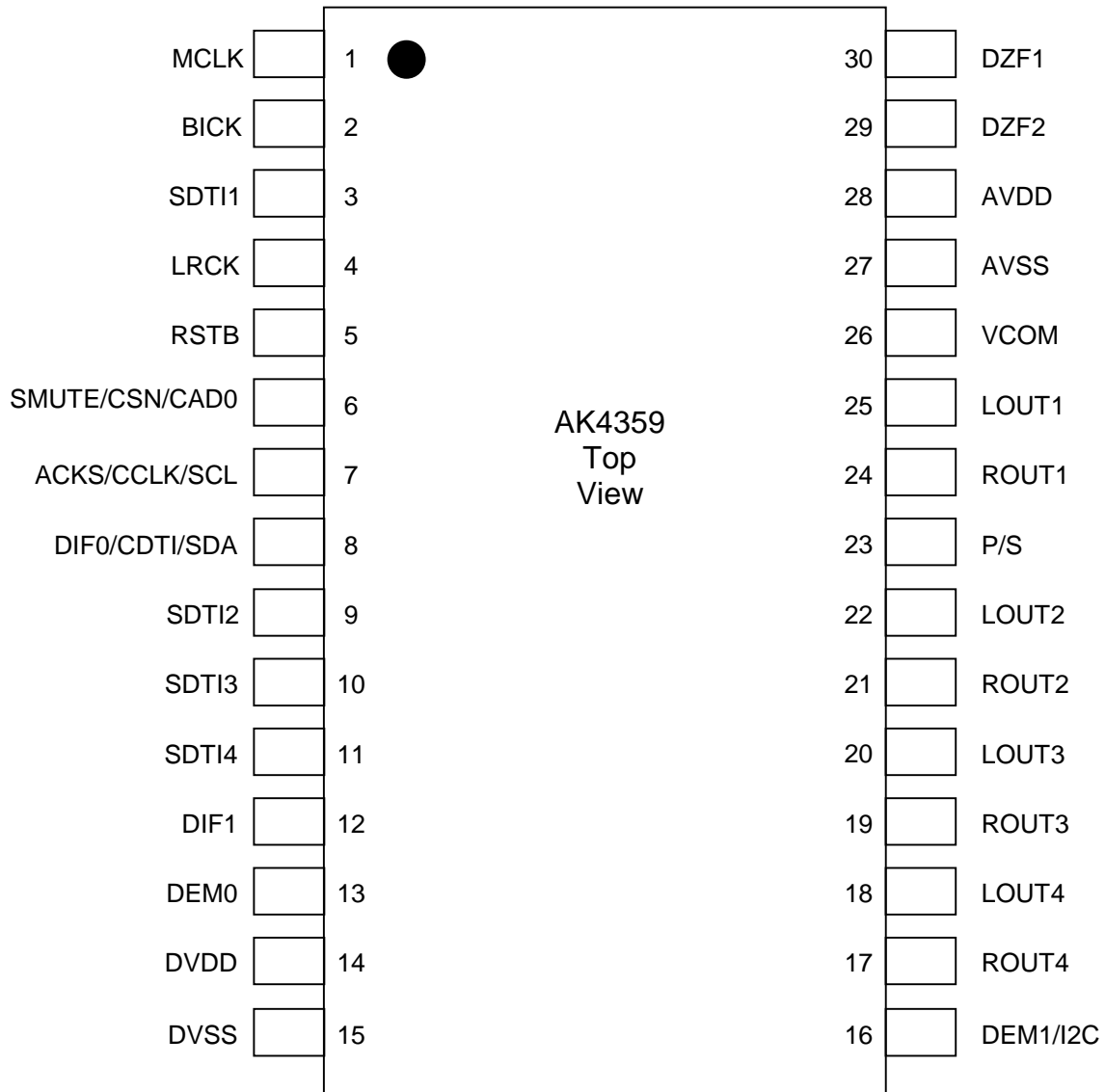

## ■ Compatibility with AK4384

### 1. Function

Functions	AK4384	AK4359
# of channels	2	8
I2C	Not available	Available
DEM control	Register	Pin/Register
16/20bit LSB justified format control	Register	Pin/Register

### 2. Pin Configuration

AK4359	AK4384	Pin#	Pin#	AK4384	AK4359
MCLK	MCLK	1	30	DZFL	DZF1
BICK	BICK	2	29	DZFR	DZF2
SDTI1	SDTI	3	28	VDD	AVDD
LRCK	LRCK	4	27	VSS	AVSS
RSTB	PDN	5	26	VCOM	VCOM
SMUTE/CSN/CAD0	SMUTE/CSN	6	25	AOUTL	LOUT1
ACKS/CCLK/SCL	ACKS/CCLK	7	24	AOUTR	ROUT1
DIF0/CDTI/SDA	DIF0/CDTI	8	23	P/S	P/S
SDTI2		9	22		LOUT2
SDTI3		10	21		ROUT2
SDTI4		11	20		LOUT3
DIF1		12	19		ROUT3
DEM0		13	18		LOUT4
DVDD		14	17		ROUT4
DVSS		15	16		I2C/DEM1

### 3. Register map

Addr	Register Name	D7	D6	D5	D4	D3	D2	D1	D0
00H	Control 1	ACKS	TDM1	TDM0	DIF2	DIF1	DIF0	PW1	RSTN
01H	Control 2	0	0	SLOW	DFS1	DFS0	DEM1	DEM0	SMUTE
02H	Control 3	PW4	PW3	PW2	0	0	DZFB	0	0
03H	LOUT1 ATT Control	ATT7	ATT6	ATT5	ATT4	ATT3	ATT2	ATT1	ATT0
04H	ROUT1 ATT Control	ATT7	ATT6	ATT5	ATT4	ATT3	ATT2	ATT1	ATT0
05H	LOUT2 ATT Control	ATT7	ATT6	ATT5	ATT4	ATT3	ATT2	ATT1	ATT0
06H	ROUT2 ATT Control	ATT7	ATT6	ATT5	ATT4	ATT3	ATT2	ATT1	ATT0
07H	LOUT3 ATT Control	ATT7	ATT6	ATT5	ATT4	ATT3	ATT2	ATT1	ATT0
08H	ROUT3 ATT Control	ATT7	ATT6	ATT5	ATT4	ATT3	ATT2	ATT1	ATT0
09H	LOUT4 ATT Control	ATT7	ATT6	ATT5	ATT4	ATT3	ATT2	ATT1	ATT0
0AH	ROUT4 ATT Control	ATT7	ATT6	ATT5	ATT4	ATT3	ATT2	ATT1	ATT0
0BH	Invert Output Signal	INVL1	INVR1	INVL2	INVR2	INVL3	INVR3	INVL4	INVR4
0CH	DZF1 Control	L1	R1	L2	R2	L3	R3	L4	R4
0DH	DZF2 Control	L1	R1	L2	R2	L3	R3	L4	R4
0EH	DEM Control	0	0	0	0	DEMA	DEMB	DEMC	DEMD

: Compatible with AK4384's register.

PIN/FUNCTION			
No.	Pin Name	I/O	Function
1	MCLK	I	Master Clock Input Pin An external TTL clock should be input on this pin.
2	BICK	I	Audio Serial Data Clock Pin
3	SDTI1	I	DAC1 Audio Serial Data Input Pin
4	LRCK	I	L/R Clock Pin
5	RSTB	I	Reset Mode Pin When at "L", the AK4359 is in the reset mode. The AK4359 must be reset once upon power-up.
6	SMUTE	I	Soft Mute Pin in parallel control mode "H": Enable, "L": Disable
	CSN	I	Chip Select Pin in serial 3-wire mode
	CAD0	I	Chip Address Pin in serial I2C mode
7	ACKS	I	Auto Setting Mode Pin in parallel control mode "L": Manual Setting Mode, "H": Auto Setting Mode
	CCLK	I	Control Data Clock Pin in serial 3-wire mode
	SCL		Control Data Clock Pin in serial I2C mode
8	DIF0	I	Audio Data Interface Format Pin in parallel control mode
	CDTI	I	Control Data Input Pin in serial 3-wire mode
	SDA	I/O	Control Data Pin in serial I2C mode
9	SDTI2	I	DAC2 Audio Serial Data Input Pin
10	SDTI3	I	DAC3 Audio Serial Data Input Pin
11	SDTI4	I	DAC4 Audio Serial Data Input Pin
12	DIF1	I	Audio Data Interface Format Pin
13	DEM0	I	De-emphasis Filter Enable Pin
14	DVDD		Digital Power Supply Pin, +4.5~+5.5V
15	DVSS		Digital Ground Pin
16	I2C	I	Control Mode Select Pin in serial control mode "L": 3-wire Serial, "H": I <sup>2</sup> C Bus
	DEM1	I	De-emphasis Filter Enable Pin in parallel control mode
17	ROUT4	O	DAC4 Rch Analog Output Pin
18	LOUT4	O	DAC4 Lch Analog Output Pin
19	ROUT3	O	DAC3 Rch Analog Output Pin
20	LOUT3	O	DAC3 Lch Analog Output Pin
21	ROUT2	O	DAC2 Rch Analog Output Pin
22	LOUT2	O	DAC2 Lch Analog Output Pin
23	P/S	I	Parallel/Serial Select Pin (Internal pull-up pin) "L": Serial control mode, "H": Parallel control mode
24	ROUT1	O	DAC1 Rch Analog Output Pin
25	LOUT1	O	DAC1 Lch Analog Output Pin
26	VCOM	O	Common Voltage Pin, AVDD/2 Normally connected to AVSS with a 0.1μF ceramic capacitor in parallel with a 10μF electrolytic cap.
27	AVSS	-	Analog Ground Pin
28	AVDD	-	Analog Power Supply Pin, +4.5~+5.5V
29	DZF2	O	Data Zero Input Detect Pin
30	DZF1	O	Data Zero Input Detect Pin

Note: All input pins except pull-up pin should not be left floating.

## ■ Handling of Unused Pin

The unused I/O pins should be processed appropriately as below.

Classification	Pin Name	Setting
Analog	LOUT4-1, ROUT4-1	Leave open.
Digital	DZF2-1	Leave open.
	SDTI4-1	Connect to DVSS.
	SMUTE (Parallel control mode)	
	DEM0, DIF1 (Serial control mode)	Connect to DVDD or DVSS.

## ABSOLUTE MAXIMUM RATINGS

(AVSS=DVSS=0V; Note 1)

Parameter	Symbol	Min	Max	Units	
Power Supplies	Analog	AVDD	-0.3	6.0	V
	Digital	DVDD	-0.3	6.0	V
	AVSS-DVSS  (Note 2)	$\Delta$ GND	-	0.3	V
Input Current (any pins except for supplies)	IIN	-	$\pm$ 10	mA	
Analog Input Voltage	VINA	-0.3	AVDD+0.3	V	
Digital Input Voltage	VIND	-0.3	DVDD+0.3	V	
Ambient Operating Temperature	Ta	-40	85	°C	
Storage Temperature	Tstg	-65	150	°C	

Note 1. All voltages with respect to ground.

Note 2. AVSS and DVSS must be connected to the same analog ground plane.

WARNING: Operation at or beyond these limits may result in permanent damage to the device.  
Normal operation is not guaranteed at these extremes.

## RECOMMENDED OPERATING CONDITIONS

(AVSS=DVSS=0V; Note 1)

Parameter	Symbol	Min	Typ	Max	Units	
Power Supplies (Note 3)	Analog	AVDD	4.5	5.0	5.5	V
	Digital	DVDD	4.5	5.0	5.5	V

Note 3. The power up sequence between AVDD and DVDD is not critical.

\*AKM assumes no responsibility for the usage beyond the conditions in this datasheet.

<b>ANALOG CHARACTERISTICS</b>
-------------------------------

(Ta=25°C; AVDD=DVDD=5V; fs=44.1kHz; BICK=64fs; Signal Frequency=1kHz; 24bit Input Data;  
Measurement frequency=20Hz ~ 20kHz; R<sub>L</sub> ≥5kΩ; unless otherwise specified)

Parameter		Min	Typ	Max	Units	
Resolution				24	Bits	
<b>Dynamic Characteristics</b> (Note 4)						
THD+N	Fs=44.1kHz	0dBFS		-94	-84	dB
	BW=20kHz	-60dBFS		-42	-	dB
	fs=96kHz	0dBFS		-92	-	dB
	BW=40kHz	-60dBFS		-39	-	dB
	fs=192kHz	0dBFS		-92	-	dB
	BW=40kHz	-60dBFS		-39	-	dB
Dynamic Range (-60dBFS with A-weighted)	(Note 5)	98	106		dB	
S/N (A-weighted)	(Note 6)	98	106		dB	
Interchannel Isolation (1kHz)		90	100		dB	
Interchannel Gain Mismatch			0.2	0.5	dB	
<b>DC Accuracy</b>						
Gain Drift			100	-	ppm/°C	
Output Voltage	(Note 7)	3.15	3.4	3.65	V <sub>pp</sub>	
Load Resistance	(Note 8)	5			kΩ	
<b>Power Supplies</b>						
Power Supply Current (AVDD+DVDD)						
Normal Operation (RSTB pin = "H", fs≤96kHz)			55	85	mA	
Normal Operation (RSTB pin = "H", fs=192kHz)			63	90	mA	
Reset Mode (RSTB pin = "L")	(Note 9)		60	150	μA	

Note 4. Measured by Audio Precision System Two. Refer to the evaluation board manual.

Note 5. 100dB at 16bit data.

Note 6. S/N does not depend on input bit length.

Note 7. Full scale voltage (0dB). Output voltage scales with the voltage of AVDD pin. AOUT (typ. @0dB) =  
3.4V<sub>pp</sub>×AVDD/5.0

Note 8. For AC-load.

Note 9. P/S pin is tied to DVDD and the other all digital input pins including clock pins (MCLK, BICK, LRCK) are tied to DVSS.

### SHARP ROLL-OFF FILTER CHARACTERISTICS

(Ta = 25°C; AVDD=DVDD = 4.5 ~ 5.5V; fs = 44.1kHz; DEM = OFF; SLOW = "0")

Parameter	Symbol	Min	Typ	Max	Units		
<b>Digital filter</b>							
Passband	±0.05dB (Note 10) -6.0dB	PB	0	22.05	20.0	kHz	
			-		-	kHz	
Stopband	(Note 10)	SB	24.1			kHz	
Passband Ripple		PR			± 0.02	dB	
Stopband Attenuation		SA	54			dB	
Group Delay	(Note 11)	GD	-	19.3	-	1/fs	
<b>Digital Filter + SCF</b>							
Frequency Response	20.0kHz	Fs=44.1kHz	FR	-	+ 0.06/-0.10	-	dB
	40.0kHz	Fs=96kHz	FR	-	+ 0.06/-0.13	-	dB
	80.0kHz	Fs=192kHz	FR	-	+ 0.06/-0.51	-	dB

Note 10. The passband and stopband frequencies scale with fs(system sampling rate). For example, PB=0.4535×fs (@±0.05dB), SB=0.546×fs.

Note 11. The calculating delay time which occurred by digital filtering. This time is from setting the 16/24bit data of both channels to input register to the output of analog signal.

### SLOW ROLL-OFF FILTER CHARACTERISTICS

(Ta = 25°C; AVDD=DVDD = 4.5~5.5V; fs = 44.1kHz; DEM = OFF; SLOW = "1")

Parameter	Symbol	Min	Typ	Max	Units		
<b>Digital Filter</b>							
Passband	±0.04dB (Note 12) -3.0dB	PB	0	18.2	8.1	kHz	
			-		-	kHz	
Stopband	(Note 12)	SB	39.2			kHz	
Passband Ripple		PR			± 0.005	dB	
Stopband Attenuation		SA	72			dB	
Group Delay	(Note 11)	GD	-	19.3	-	1/fs	
<b>Digital Filter + SCF</b>							
Frequency Response	20.0kHz	fs=44.kHz	FR	-	+0.1/-4.3	-	dB
	40.0kHz	fs=96kHz	FR	-	+0.1/-3.3	-	dB
	80.0kHz	fs=192kHz	FR	-	+0.1/-3.7	-	dB

Note 12. The passband and stopband frequencies scale with fs. For example, PB = 0.185×fs (@±0.04dB), SB = 0.888×fs.

### DC CHARACTERISTICS

(Ta = 25°C; AVDD=DVDD = 4.5 ~ 5.5V)

Parameter	Symbol	Min	Typ	Max	Units	
High-Level Input Voltage	VIH	2.2	-	-	V	
Low-Level Input Voltage	VIL	-	-	0.8	V	
High-Level Output Voltage (Iout = -80μA)	VOH	DVDD-0.4	-	-	V	
Low-Level Output Voltage	(DZF1, DZF2 pins: Iout= 80μA) (SDA pins: Iout= 3mA)	VOL	-	-	0.4	V
		VOL	-	-	0.4	V
Input Leakage Current	Iin	-	-	± 10	μA	

Note 13. P/S pin has internal pull-up device, nominally 100kΩ.

<b>SWITCHING CHARACTERISTICS</b>
----------------------------------

(Ta = 25°C; AVDD, DVDD = 4.5 ~ 5.5V; CL = 20pF)

Parameter	Symbol	Min	Typ	Max	Units
<b>Master Clock Frequency</b>	fCLK	2.048	11.2896	36.864	MHz
Duty Cycle	dCLK	40		60	%
<b>LRCK Frequency</b>					
<b>Normal Mode (TDM0= "0", TDM1= "0")</b>					
Normal Speed Mode	fsn	8		48	kHz
Double Speed Mode	fsd	60		96	kHz
Quad Speed Mode	fsq	120		192	kHz
Duty Cycle	Duty	45		55	%
<b>TDM256 mode (TDM0= "1", TDM1= "0")</b>					
Normal Speed Mode	fsn	8		48	kHz
High time	tLRH	3/256fs			ns
Low time	tLRL	3/256fs			ns
<b>TDM128 mode (TDM0= "1", TDM1= "1")</b>					
Normal Speed Mode	fsn	8		48	kHz
Double Speed Mode	fsd	60		96	kHz
High time	tLRH	3/128fs			ns
Low time	tLRL	3/128fs			ns
<b>Audio Interface Timing</b>					
BICK Period	tBCK	81			ns
BICK Pulse Width Low	tBCKL	30			ns
Pulse Width High	tBCKH	30			ns
BICK "↑" to LRCK Edge (Note 14)	tBLR	20			ns
LRCK Edge to BICK "↑" (Note 14)	tLRB	20			ns
SDTI Hold Time	tSDH	10			ns
SDTI Setup Time	tSDS	10			ns
<b>Control Interface Timing (3-wire Serial control mode):</b>					
CCLK Period	tCCK	200			ns
CCLK Pulse Width Low	tCCKL	80			ns
Pulse Width High	tCCKH	80			ns
CDTI Setup Time	tCDS	40			ns
CDTI Hold Time	tCDH	40			ns
CSN High Time	tCSW	150			ns
CSN "↓" to CCLK "↑"	tCSS	50			ns
CCLK "↑" to CSN "↑"	tCSH	50			ns
<b>Control Interface Timing (I<sup>2</sup>C Bus mode):</b>					
SCL Clock Frequency	fSCL	-		400	kHz
Bus Free Time Between Transmissions	tBUF	1.3		-	μs
Start Condition Hold Time (prior to first clock pulse)	tHD:STA	0.6		-	μs
Clock Low Time	tLOW	1.3		-	μs
Clock High Time	tHIGH	0.6		-	μs
Setup Time for Repeated Start Condition	tSU:STA	0.6		-	μs
SDA Hold Time from SCL Falling (Note 15)	tHD:DAT	0		-	μs
SDA Setup Time from SCL Rising	tSU:DAT	0.1		-	μs
Rise Time of Both SDA and SCL Lines	tR	-		0.3	μs
Fall Time of Both SDA and SCL Lines	tF	-		0.3	μs
Setup Time for Stop Condition	tSU:STO	0.6		-	μs
Pulse Width of Spike Noise Suppressed by Input Filter	tSP	0		50	ns

Parameter	Symbol	Min	Typ	Max	Units
<b>Reset Timing</b> RSTB Pulse Width (Note 16)	tRST	150			ns

Note 14. BICK rising edge must not occur at the same time as LRCK edge.

Note 15. Data must be held for sufficient time to bridge the 300 ns transition time of SCL.

Note 16. The AK4359 can be reset by bringing RSTB pin = “L”.

Note 17. I<sup>2</sup>C-bus is a trademark of NXP B.V.

■ Timing Diagram

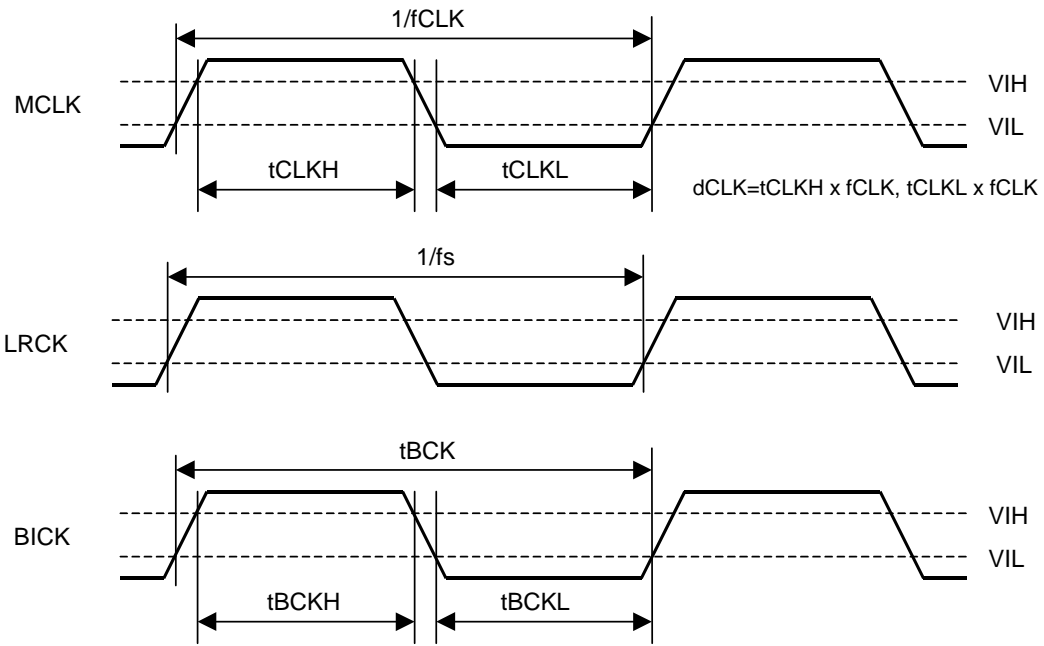

Clock Timing

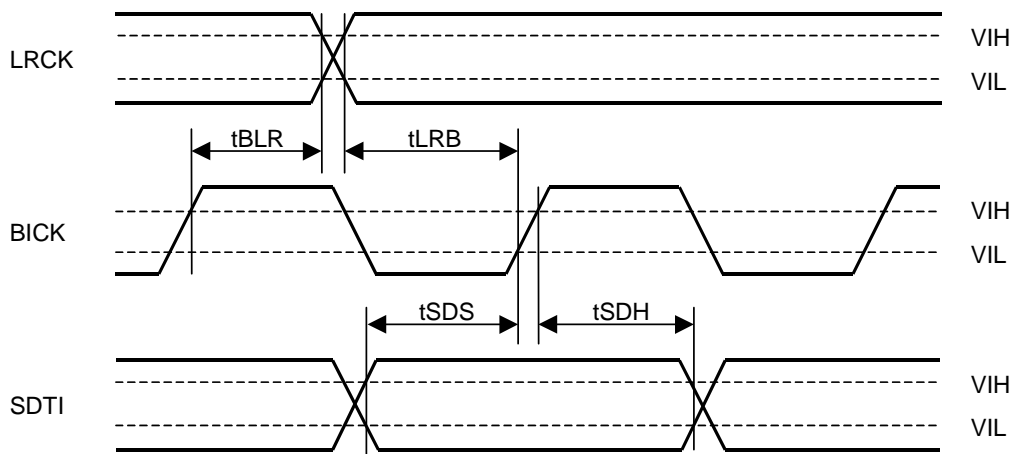

Audio Serial Interface Timing

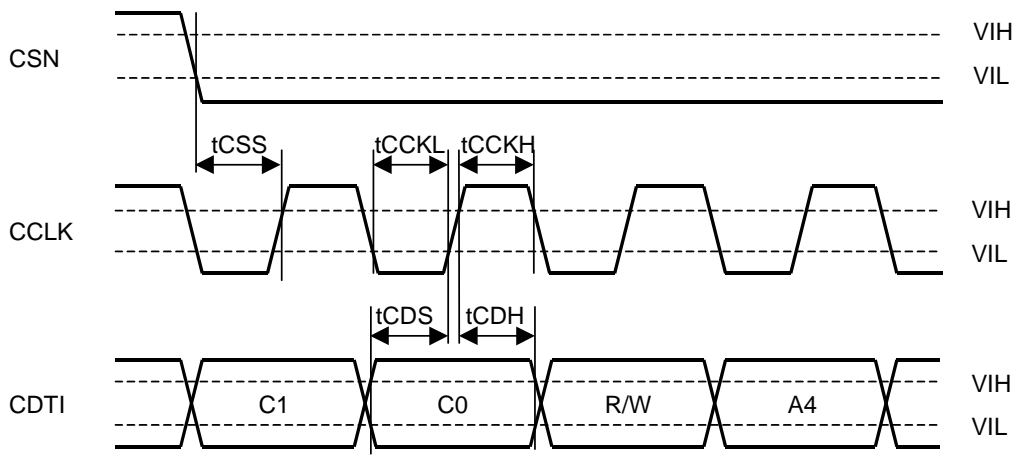

WRITE Command Input Timing

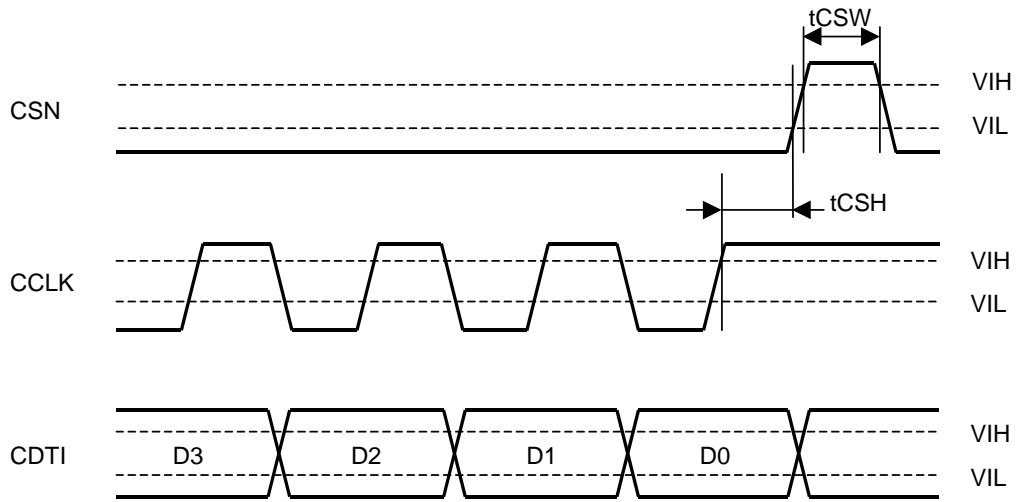

WRITE Data Input Timing

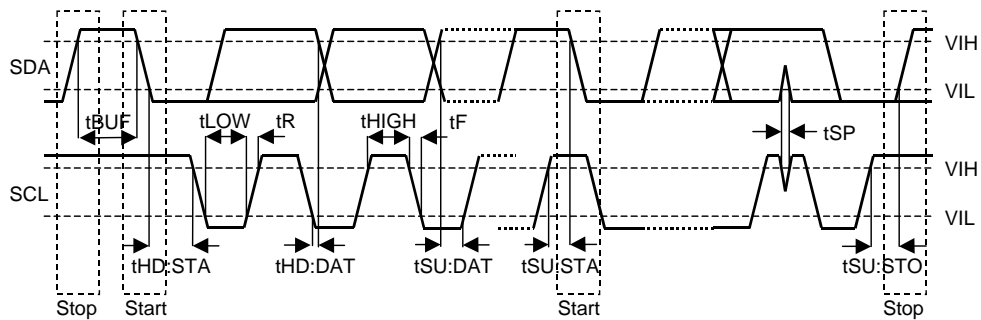

I<sup>2</sup>C Bus mode Timing

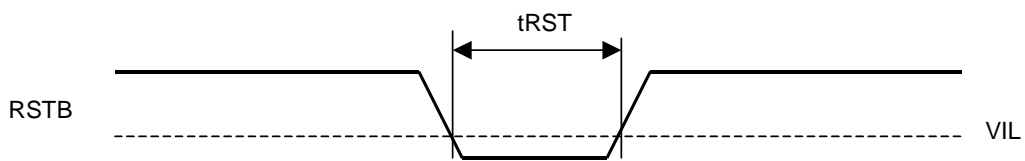

Reset Timing

<b>OPERATION OVERVIEW</b>
---------------------------

## ■ System Clock

The external clocks, which are required to operate the AK4359, are MCLK, LRCK and BICK. The master clock (MCLK) should be synchronized with LRCK but the phase is not critical. The MCLK is used to operate the digital interpolation filter and the delta-sigma modulator. There are two methods to set MCLK frequency. In Manual Setting Mode (ACKS bit = "0": Register 00H), the sampling speed is set by DFS0-1 bits (Table 1). The frequency of MCLK at each sampling speed is set automatically. (Table 2~Table 4) In Auto Setting Mode (ACKS bit = "1": Default), as MCLK frequency is detected automatically (Table 5), and the internal master clock becomes the appropriate frequency (Table 6), it is not necessary to set DFS0-1.

In parallel control mode, the sampling speed can be set by only ACKS pin. When ACKS pin = "L", the AK4359 operates by Normal Speed Mode. When ACKS pin = "H", Auto setting mode is enabled. The parallel control mode does not support 128fs and 192fs of Double Speed Mode.

All external clocks (MCLK, BICK and LRCK) should always be present whenever the AK4359 is in the normal operation mode (RSTB pin = "H"). If these clocks are not provided, the AK4359 may draw excess current and may fall into unpredictable operation. This is because the device utilizes dynamic refreshed logic internally. The AK4359 should be reset by RSTB pin = "L" after these clocks are provided. If the external clocks are not present, the AK4359 should be in the power-down mode (RSTB pin = "L"). After exiting reset(RSTB = "↑") at power-up etc., the AK4359 is in the power-down mode until MCLK is input.

DFS1	DFS0	Sampling Rate (fs)		Default
0	0	Normal Speed Mode	8kHz~48kHz	
0	1	Double Speed Mode	60kHz~96kHz	
1	0	Quad Speed Mode	120kHz~192kHz	

Table 1. Sampling Speed (Manual Setting Mode)

LRCK fs	MCLK					BICK 64fs
	256fs	384fs	512fs	768fs	1152fs	
32.0kHz	8.1920MHz	12.2880MHz	16.3840MHz	24.5760MHz	36.8640MHz	2.0480MHz
44.1kHz	11.2896MHz	16.9344MHz	22.5792MHz	33.8688MHz	N/A	2.8224MHz
48.0kHz	12.2880MHz	18.4320MHz	24.5760MHz	36.8640MHz	N/A	3.0720MHz

Table 2. System Clock Example (Normal Speed Mode @Manual Setting Mode)

LRCK	MCLK				BICK
fs	128fs	192fs	256fs	384fs	64fs
88.2kHz	106896MHz	16.9344MHz	22.5792MHz	33.8688MHz	5.6448MHz
96.0kHz	12.2880MHz	18.4320MHz	24.5760MHz	36.8640MHz	6.1440MHz

Table 3. System Clock Example (Double Speed Mode @Manual Setting Mode)

LRCK	MCLK		BICK
fs	128fs	192fs	64fs
176.4kHz	22.5792MHz	33.8688MHz	106896MHz
192.0kHz	24.5760MHz	36.8640MHz	12.2880MHz

Table 4. System Clock Example (Quad Speed Mode @Manual Setting Mode)

MCLK		Sampling Speed
512fs	768fs	Normal
256fs	384fs	Double
128fs	192fs	Quad

Table 5. Sampling Speed (Auto Setting Mode)

LRCK	MCLK (MHz)							Sampling Speed	
	fs	128fs	192fs	256fs	384fs	512fs	768fs		1152fs
32.0kHz	-	-	-	-	-	16.3840	24.5760	36.8640	Normal
44.1kHz	-	-	-	-	-	22.5792	33.8688	-	
48.0kHz	-	-	-	-	-	24.5760	36.8640	-	
88.2kHz	-	-	22.5792	33.8688	-	-	-	-	Double
96.0kHz	-	-	24.5760	36.8640	-	-	-	-	
176.4kHz	22.5792	33.8688	-	-	-	-	-	-	Quad
192.0kHz	24.5760	36.8640	-	-	-	-	-	-	

Table 6. System Clock Example (Auto Setting Mode)

■ Audio Serial Interface Format

In parallel control mode, the DIF0-1 pins as shown in Table 7 can select four serial data modes. In serial mode, the DIF0-2 bits shown in Table 8 can select five serial data modes. Initial value of DIF0-2 bits is “010”. The setting of DIF1 pin is ignored. In all modes the serial data is MSB-first, 2’s complement format and is latched on the rising edge of BICK. Mode 2 can be used for 16/20 MSB justified formats by zeroing the unused LSBs.

In serial control mode, when TDM0 bit = “1”, the audio interface becomes TDM mode. In TDM256 mode (TDM1 bit = “0”, Table 9), the serial data of all DAC (eight channels) is input to the SDTI1 pin. The input data to SDTI2-4 pins is ignored. BICK should be fixed to 256fs. “H” time and “L” time of LRCK should be 3/256fs at least. The serial data is MSB-first, 2’s complement format. The input data to SDTI1 pin is latched on the rising edge of BICK. In TDM128 mode (TDM1 bit = “1”, Table 10), the serial data of DAC (four channels; L1, R1, L2, R2) is input to the SDTI1 pin. Other four data (L3, R3, L4, R4) is input to the SDTI2. The input data to SDTI3-4 pins is ignored. BICK should be fixed to 128fs.

Mode	DIF1	DIF0	SDTI Format	LRCK	BICK	Figure
0	0	0	16bit LSB Justified	H/L	≥32fs	Figure 1
1	0	1	20bit LSB Justified	H/L	≥40fs	Figure 2
2	1	0	24bit MSB Justified	H/L	≥48fs	Figure 3
3	1	1	24bit I <sup>2</sup> S Compatible	L/H	≥48fs	Figure 4

Table 7. Audio Data Formats (Parallel control mode)

Mode	TDM1	TDM0	DIF2	DIF1	DIF0	SDTI Format	LRCK	BICK	Figure
0	0	0	0	0	0	16bit LSB Justified	H/L	≥32fs	Figure 1
1	0	0	0	0	1	20bit LSB Justified	H/L	≥40fs	Figure 2
2	0	0	0	1	0	24bit MSB Justified	H/L	≥48fs	Figure 3
3	0	0	0	1	1	24bit I <sup>2</sup> S Compatible	L/H	≥48fs	Figure 4
4	0	0	1	0	0	24bit LSB Justified	H/L	≥48fs	Figure 2

Default

Table 8. Audio Data Formats (Serial control mode)

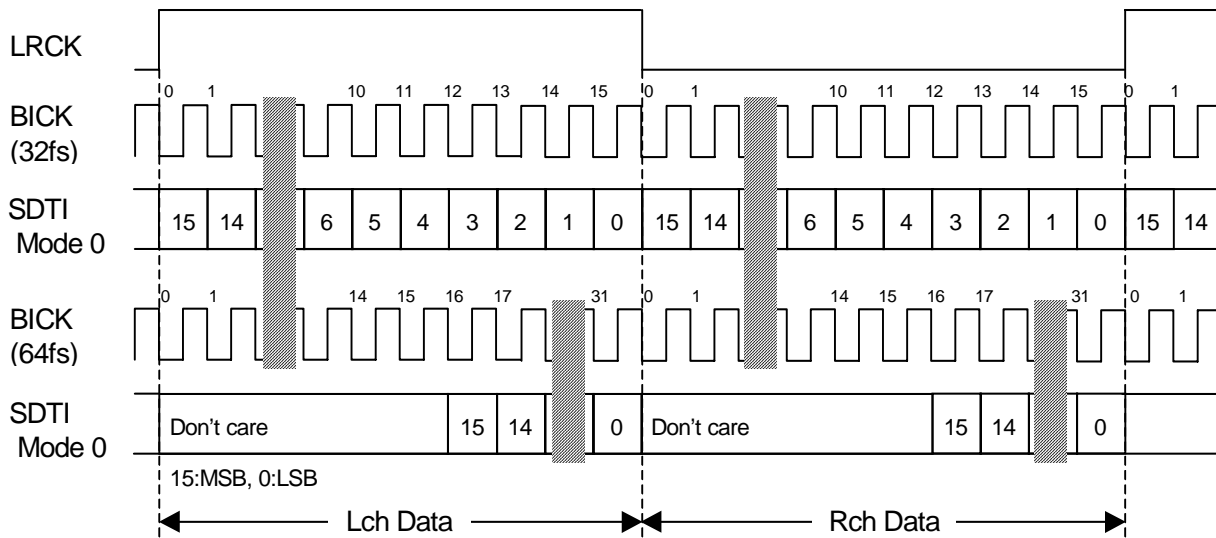

Figure 1. Mode 0 Timing

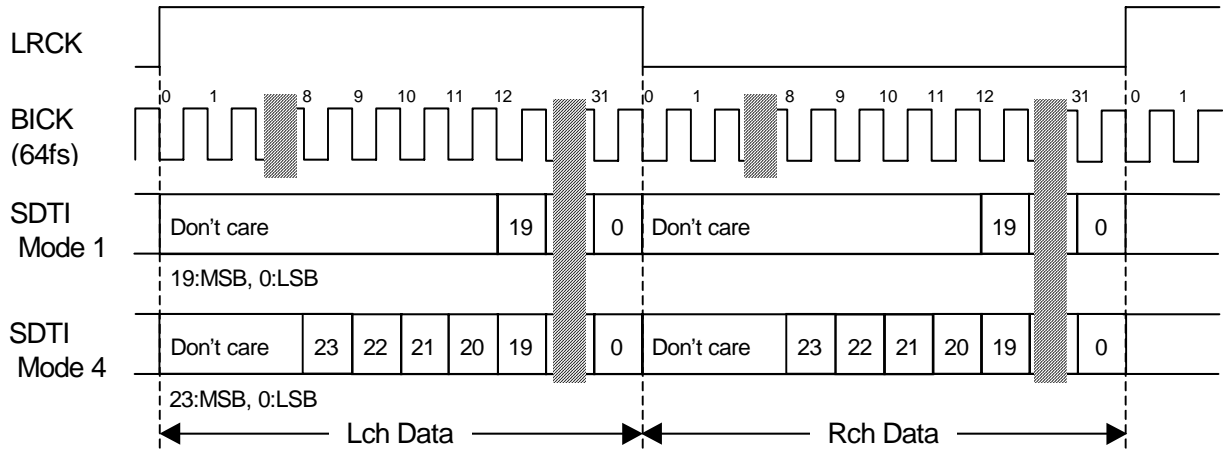

Figure 2. Mode 1,4 Timing

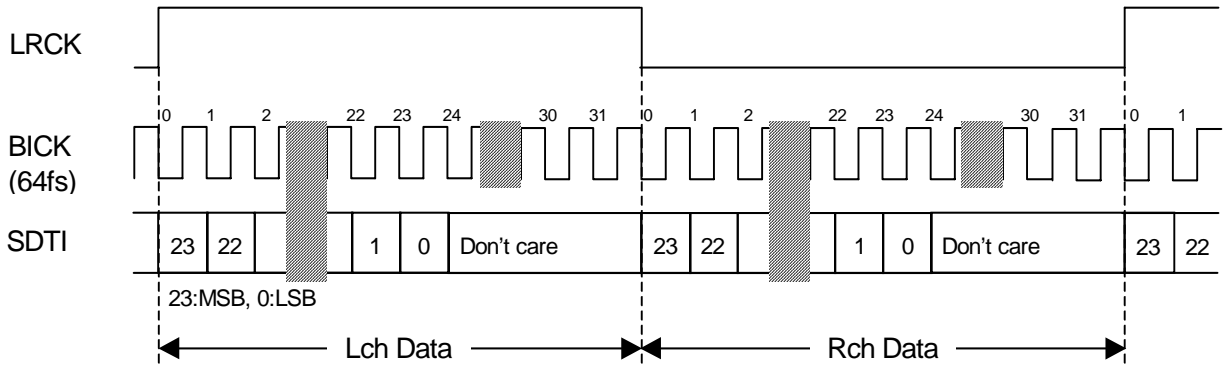

Figure 3. Mode 2 Timing

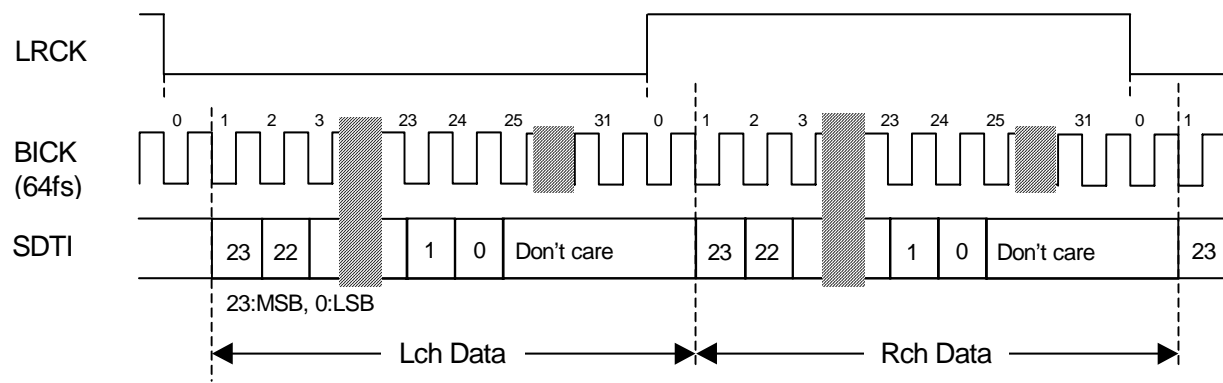

Figure 4. Mode 3 Timing

Mode	TDM1	TDM0	DIF2	DIF1	DIF0	SDTI Format	LRCK	BICK	Figure
	0	1	0	0	0	N/A			
	0	1	0	0	1	N/A			
5	0	1	0	1	0	24bit MSB Justified	↑	256fs	Figure 5
6	0	1	0	1	1	24bit I <sup>2</sup> S Compatible	↓	256fs	Figure 6
7	0	1	1	0	0	24bit LSB Justified	↑	256fs	Figure 7

Table 9. Audio Data Formats (TDM256 mode)

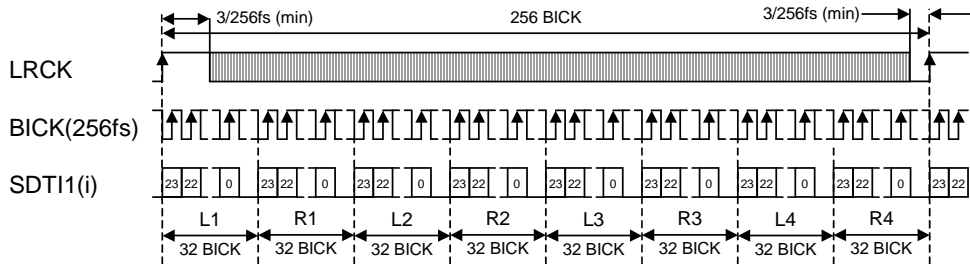

Figure 5. Mode 5 Timing

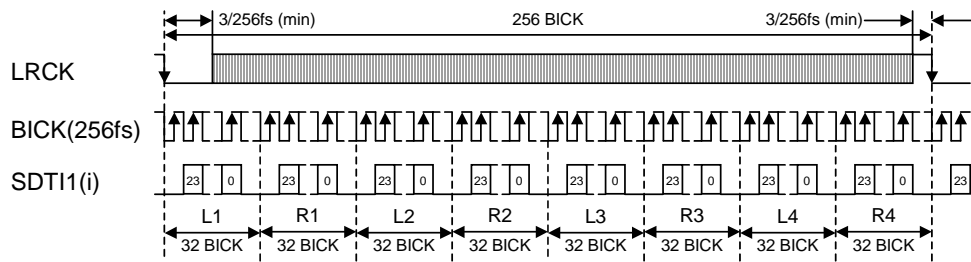

Figure 6. Mode 6 Timing

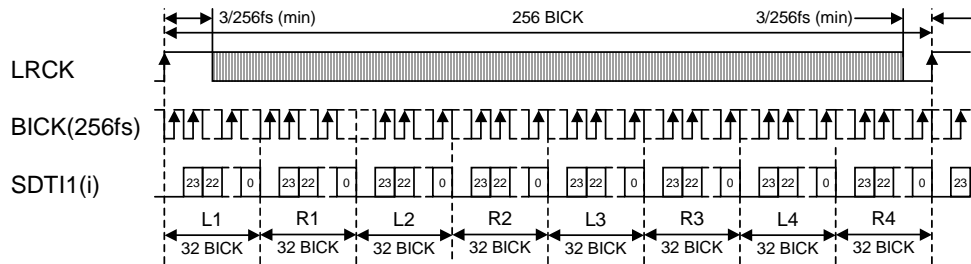

Figure 7. Mode 7 Timing

Mode	TDM1	TDM0	DIF2	DIF1	DIF0	SDTI Format	LRCK	BICK	Figure
	1	1	0	0	0	N/A			
	1	1	0	0	1	N/A			
8	1	1	0	1	0	24bit MSB Justified	↑	128fs	Figure 8
9	1	1	0	1	1	24bit I <sup>2</sup> S Compatible	↓	128fs	Figure 9
10	1	1	1	0	0	24bit LSB Justified	↑	128fs	Figure 10

Table 10. Audio Data Formats (TDM128 mode)

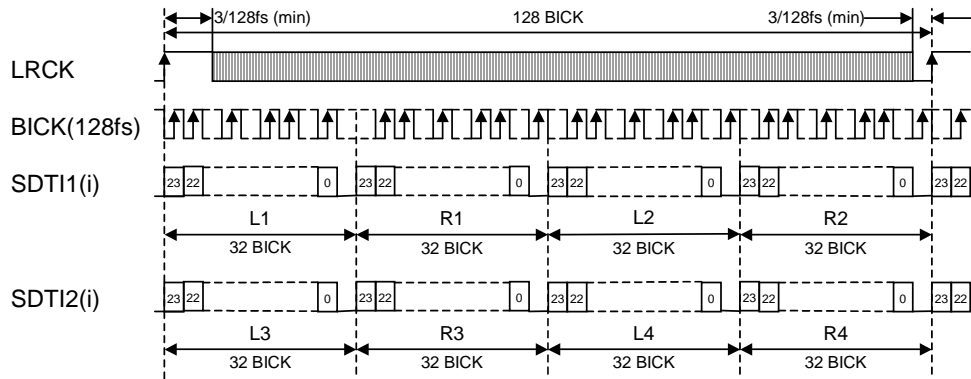

Figure 8. Mode 8 Timing

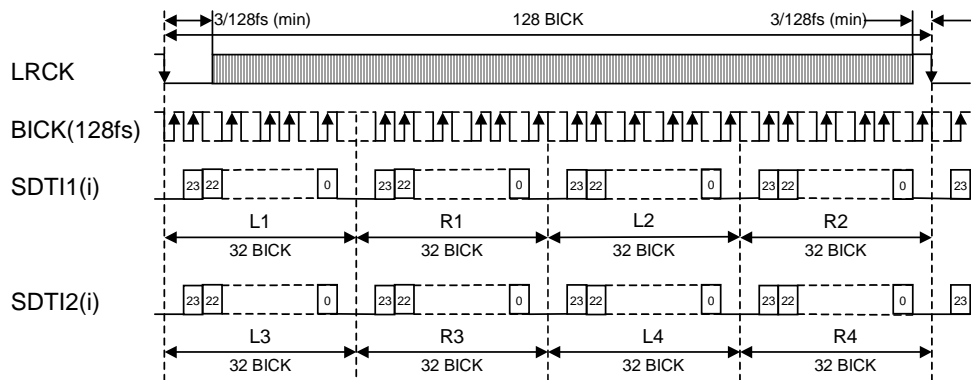

Figure 9. Mode 9 Timing

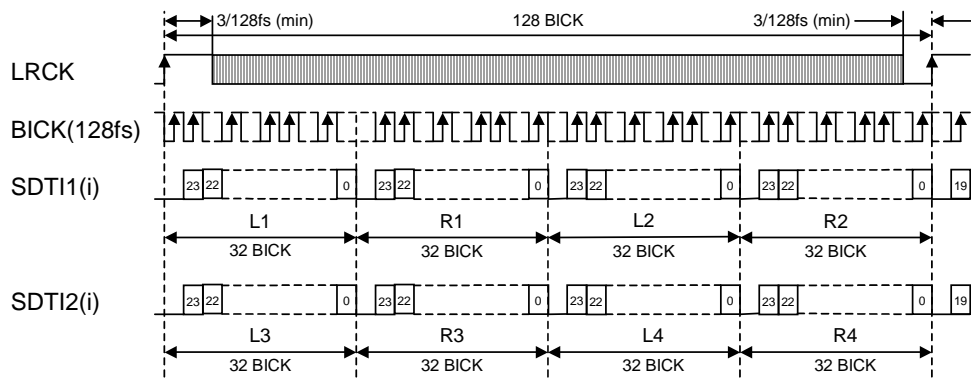

Figure 10. Mode 10 Timing

## ■ De-emphasis Filter

A digital de-emphasis filter is available for 32, 44.1 or 48kHz sampling rates ( $t_c = 50/15\mu s$ ). In case of double speed and quad speed mode, the digital de-emphasis filter is always off. In serial control mode, the DEM0-1 bits are valid for the DAC enabled by the DEMA-D bits. In parallel control mode, DEM0-1 pins are valid.

DEM1	DEM0	Mode
0	0	44.1kHz
0	1	OFF
1	0	48kHz
1	1	32kHz

Default

Table 11. De-emphasis Filter Control (Normal Speed Mode)

## ■ Output Volume

The AK4359 includes channel independent digital output volumes (ATT) with 256 levels at linear step including MUTE. These volumes are in front of the DAC and can attenuate the input data from 0dB to -48dB and mute. When changing levels, transitions are executed via soft changes; thus no switching noise occurs during these transitions. The transition time of 1 level and all 256 levels is shown in [Table 12](#). The attenuation level is calculated by  $ATT = 20 \log_{10} (ATT\_DATA / 255)$  [dB] and MUTE at  $ATT\_DATA = "0"$ .

Sampling Speed	Transition Time	
	1 Level	255 to 0
Normal Speed Mode	4LRCK	1020LRCK
Double Speed Mode	8LRCK	2040LRCK
Quad Speed Mode	16LRCK	4080LRCK

Table 12. ATT Transition time

## ■ Zero Detection

When the input data at all channels are continuously zeros for 8192 LRCK cycles, the AK4359 has Zero Detection like [Table 13](#). DZF pin immediately goes to "L" if input data of each channel is not zero after going DZF "H". If RSTN bit is "0", DZF pin goes to "H". DZF pin goes to "L" after 4~5LRCK if input data of each channel is not zero after RSTN bit returns to "1". Zero detect function can be disabled by DZFE bit. In this case, all DZF pins are always "L". When one of PW1-4 bit is set to "0", the input data of DAC that the PW bit is set to "0" should be zero in order to enable zero detection of the other channels. When all PW1-4 bits are set to "0", DZF pin fixes "L". DZFB bit can invert the polarity of DZF pin. In parallel control mode, the zero detect function is disabled and the DZF pin is fixed to "L".

DZF Pin	Operations
DZF1	ANDed output of zero detection flag of each channel set to "1" in 0CH register
DZF2	ANDed output of zero detection flag of each channel set to "1" in 0DH register

Table 13. DZF pins Operation

## ■ Soft Mute Operation

Soft mute operation is performed at digital domain. When the SMUTE bit goes to “1”, the output signal is attenuated by  $-\infty$  during  $ATT\_DATA \times ATT$  transition time (Table 12) from the current ATT level. When the SMUTE bit is returned to “0”, the mute is cancelled and the output attenuation gradually changes to the ATT level during  $ATT\_DATA \times ATT$  transition time. If the soft mute is cancelled before attenuating to  $-\infty$  after starting the operation, the attenuation is discontinued and returned to ATT level by the same cycle. The soft mute is effective for changing the signal source without stopping the signal transmission.

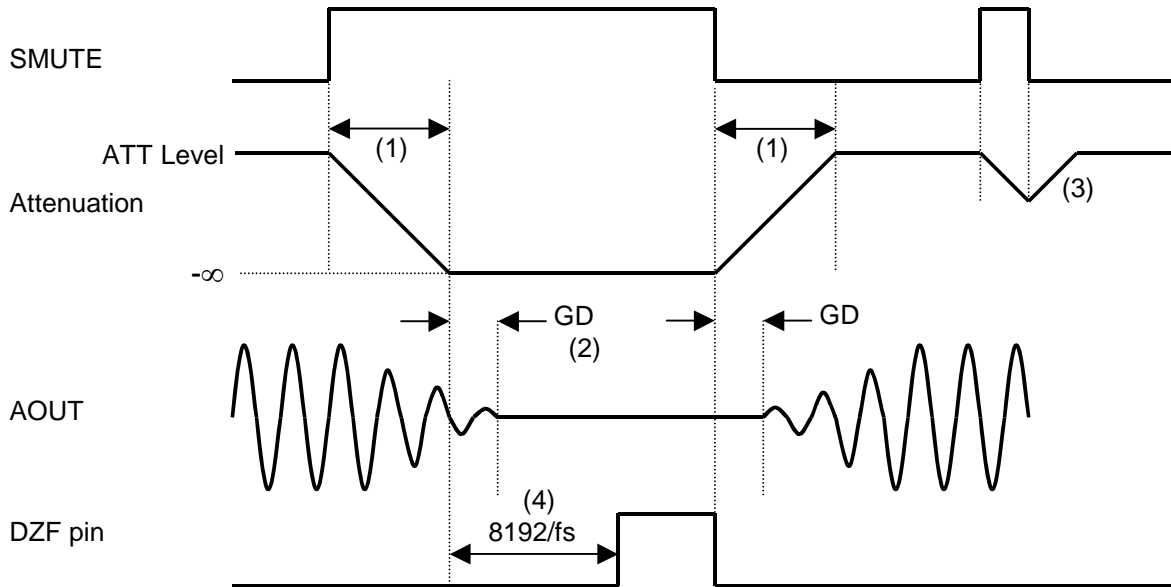

### Notes:

- (1)  $ATT\_DATA \times ATT$  transition time (Table 12). For example, in Normal Speed Mode, this time is 1020LRCK cycles ( $1020/fs$ ) at  $ATT\_DATA=255$ .
- (2) The analog output corresponding to the digital input has a group delay, GD.
- (3) If the soft mute is cancelled before attenuating to  $-\infty$  after starting the operation, the attenuation is discontinued and returned to ATT level by the same cycle.
- (4) When the input data at each channel is continuously zeros for 8192 LRCK cycles, DZF pin of each channel goes to “H”. DZF pin immediately goes to “L” if input data are not zero after going DZF “H”. In parallel control mode, the DZF pin is fixed to “L” regardless of the state of SMUTE pin.

Figure 11. Soft Mute and Zero Detection (DZFB bit = “0”)

## ■ System Reset

The AK4359 should be reset once by bringing RSTB pin = "L" upon power-up. The AK4359 is powered up and the internal timing starts clocking by LRCK "↑" after exiting reset and power down state by MCLK. The AK4359 is in the power-down mode until MCLK and LRCK are input.

## ■ Power ON/OFF timing

All DACs are placed in the power-down mode by bringing RSTB pin "L" and the registers are initialized. the analog outputs go to VCOM. As some click noise occurs at the edge of RSTB signal, the analog output should be muted externally if the click noise influences system application.

Each DAC can be powered down by setting each power-down bit (PW1-4) to "0". In this case, the registers are not initialized and the corresponding analog outputs go to VCOM. As some click noise occurs at the edge of RSTB signal, the analog output should be muted externally if the click noise influences system application.

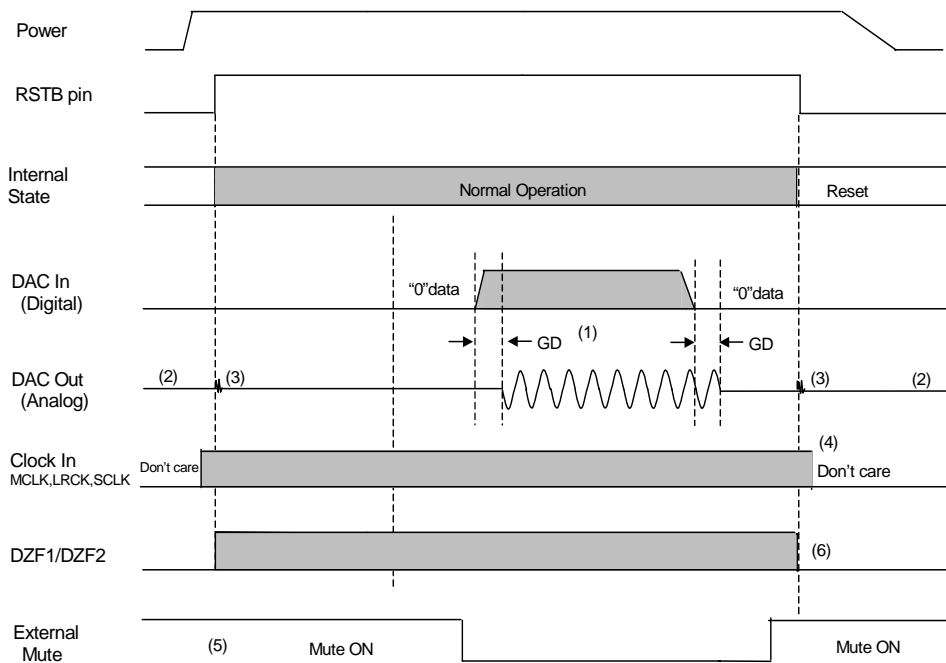

### Notes:

- (1) The analog output corresponding to digital input has the group delay (GD).
- (2) Analog outputs go to VCOM at the power-down mode.
- (3) Click noise occurs at the edge of RSTB signal. This noise is output even if "0" data is input.
- (4) The external clocks (MCLK, BICK and LRCK) can be stopped in the power-down mode (RSTB pin = "L").
- (5) Mute the analog output externally if the click noise (3) influence system application.  
The timing example is shown in this figure.
- (6) DZF pins are "L" in the power-down mode (RSTB pin = "L"). (DZFB bit = "0")

Figure 12. Power-down/up Sequence Example

### ■ Reset Function (RSTN bit)

When RSTN bit = "0", internal circuit of DAC is powered down but the registers are not initialized. The analog outputs go to VCOM voltage and DZF pins go to "H" at DZFB bit = "0". Figure 13 shows the example of reset by RSTN bit. When RSTN bit = "0", pop noise is decreased at no clock state.

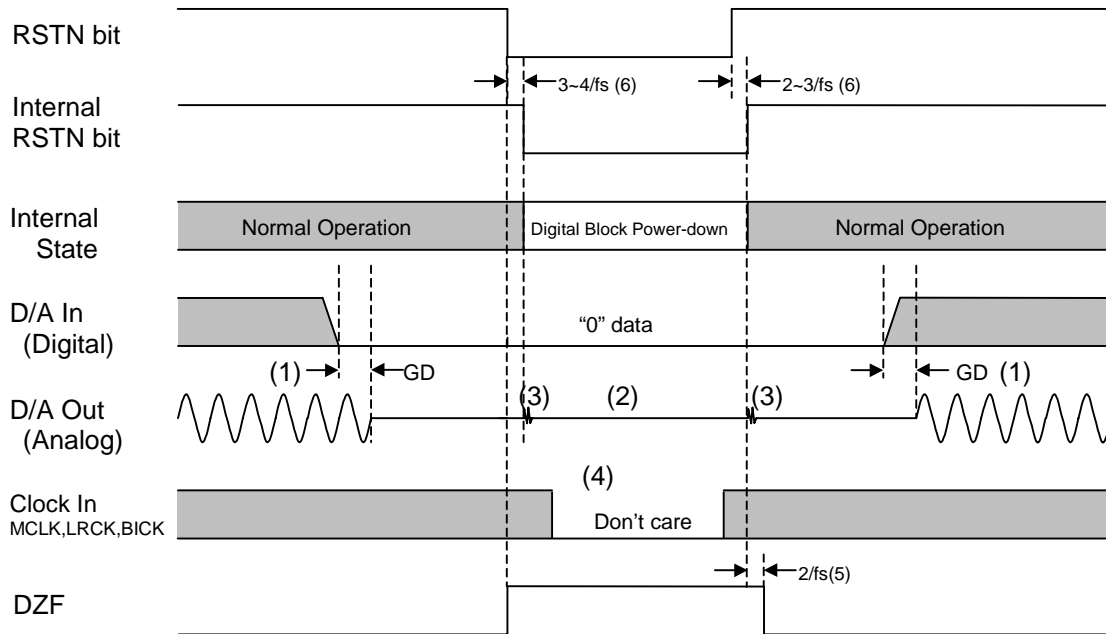

#### Notes:

- (1) The analog output corresponding to digital input has the group delay (GD).
- (2) Analog outputs go to VCOM voltage.
- (3) Small pop noise occurs at the edges ("↑ ↓") of the internal timing of RSTN bit. This noise is output even if "0" data is input.
- (4) The external clocks (MCLK, BICK and LRCK) can be stopped in the reset mode (RSTN bit = "0").
- (5) DZF pins go to "H" when the RSTN bit becomes "0", and go to "L" at  $2/f_s$  after RSTN bit becomes "1".
- (6) There is a delay,  $3 \sim 4/f_s$  from RSTN bit "0" to the internal RSTN bit "0", and  $2 \sim 3/f_s$  from RSTN bit "1" to the internal RSTN bit "1".

Figure 13. Reset Sequence Example (DZFB bit = "0")

■ Register Control Interface

The AK4359 controls its functions via registers. 2 types of control mode write internal registers. In the I<sup>2</sup>C-bus mode, the chip address is determined by the state of the CAD0 pin. In 3-wire mode, the chip address is fixed to “11”. RSTB pin = “L” initializes the registers to their default values. Writing “0” to the RSTN bit resets the internal timing circuit, but the registers are not initialized.

- \* The AK4359 does not support the read command.
- \* When the AK4359 is in the power down mode (RSTB bit = “L”) or the MCLK is not provided, Writing to control register is inhibited.
- \* When the state of P/S pin is changed, the AK4359 should be reset by RSTB bit = “L”.
- \* In serial control mode, the setting of parallel pins is invalid.

Function	Parallel Control Mode	Serial Control Mode
Double sampling mode at 128/192fs	X	O
De-emphasis	O	O
SMUTE	O	O
Zero Detection	X	O
24bit LSB justified format	X	O
TDM mode	X	O

Table 14. Function Table (O: Supported, X: Not supported)

(1) 3-wire Serial Control Mode (I2C pin = “L”)

3-wire μP interface pins, CSN, CCLK and CDTI, write internal registers. The data on this interface consists of Chip Address (2bits, C1/0; fixed to “11”), Read/Write (1bit; fixed to “1”, Write only), Register Address (MSB first, 5bits) and Control Data (MSB first, 8bits). The AK4359 latches the data on the rising edge of CCLK, so data should be clocked in on the falling edge. The writing of data becomes valid by the rising edge of CSN. The clock speed of CCLK is 5MHz (max).

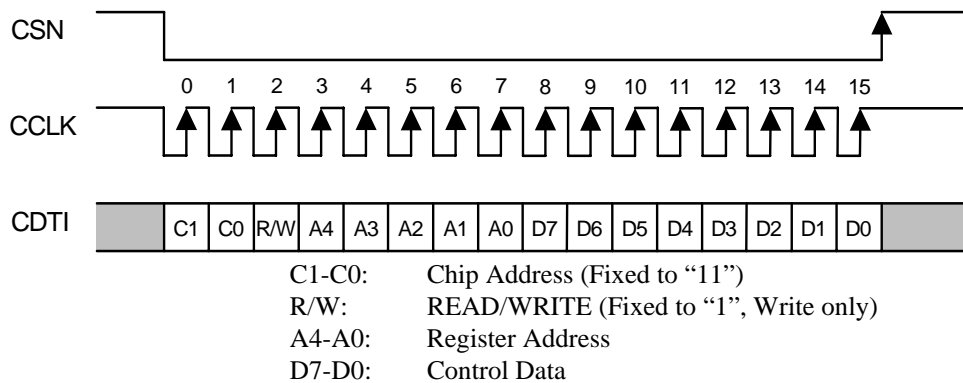

Figure 14. Control I/F Timing

(2) I<sup>2</sup>C-bus Control Mode (I2C pin = "H")

The AK4359 supports the fast-mode I<sup>2</sup>C-bus system (max: 400kHz).

Figure 15 shows the data transfer sequence at the I<sup>2</sup>C-bus mode. All commands are preceded by a START condition. A HIGH to LOW transition on the SDA line while SCL is HIGH indicates a START condition (Figure 19). After the START condition, a slave address is sent. This address is 7 bits long followed by an eighth bit which is a data direction bit (R/W) (Figure 16). The most significant six bits of the slave address are fixed as "001001". The next one bit are CAD0 (device address bit). The bit identify the specific device on the bus. The hard-wired input pin (CAD0 pin) set them. If the slave address match that of the AK4359 and R/W bit is "0", the AK4359 generates the acknowledge and the write operation is executed. If R/W bit is "1", the AK4359 generates the not acknowledge since the AK4359 can be only a slave-receiver. The master must generate the acknowledge-related clock pulse and release the SDA line (HIGH) during the acknowledge clock pulse (Figure 20).

The second byte consists of the address for control registers of the AK4359. The format is MSB first, and those most significant 3-bits are fixed to zeros (Figure 17). Those data after the second byte contain control data. The format is MSB first, 8bits (Figure 18). The AK4359 generates an acknowledge after each byte has been received. A data transfer is always terminated by a STOP condition generated by the master. A LOW to HIGH transition on the SDA line while SCL is HIGH defines a STOP condition (Figure 19).

The AK4359 is capable of more than one byte write operation by one sequence. After receipt of the third byte, the AK4359 generates an acknowledge, and awaits the next data again. The master can transmit more than one byte instead of terminating the write cycle after the first data byte is transferred. After the receipt of each data, the internal 5bits address counter is incremented by one, and the next data is taken into next address automatically. If the addresses exceed 1FH prior to generating the stop condition, the address counter will "roll over" to 00H and the previous data will be overwritten.

The data on the SDA line must be stable during the HIGH period of the clock. The HIGH or LOW state of the data line can only change when the clock signal on the SCL line is LOW (Figure 21) except for the START and the STOP condition.

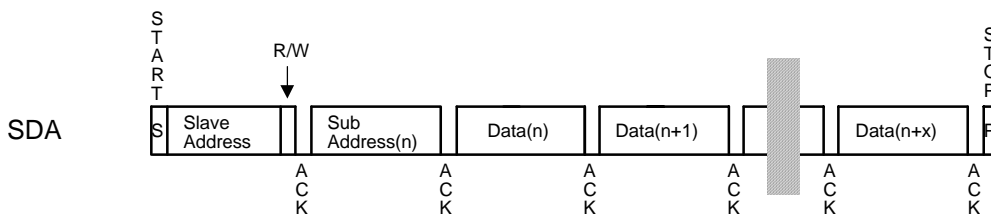

Figure 15. Data transfer sequence at the I<sup>2</sup>C-bus mode

0	0	1	0	0	1	CAD0	R/W
---	---	---	---	---	---	------	-----

(Those CAD1/0 should match with CAD1/0 pins)

Figure 16. The first byte

0	0	0	A4	A3	A2	A1	A0
---	---	---	----	----	----	----	----

Figure 17. The second byte

D7	D6	D5	D4	D3	D2	D1	D0
----	----	----	----	----	----	----	----

Figure 18. Byte structure after the second byte

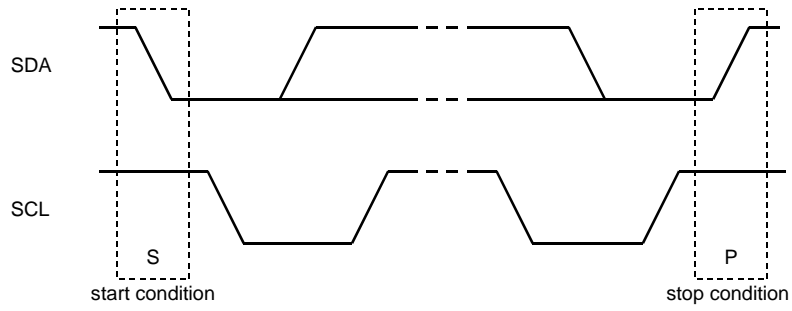

Figure 19. START and STOP conditions

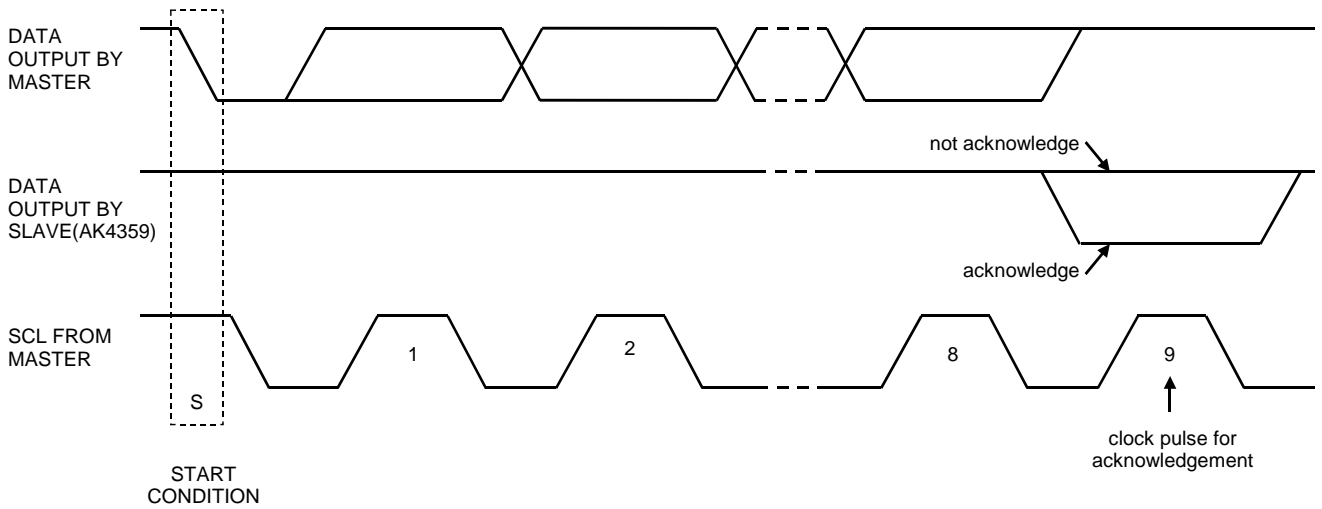

Figure 20. Acknowledge on the I<sup>2</sup>C-bus

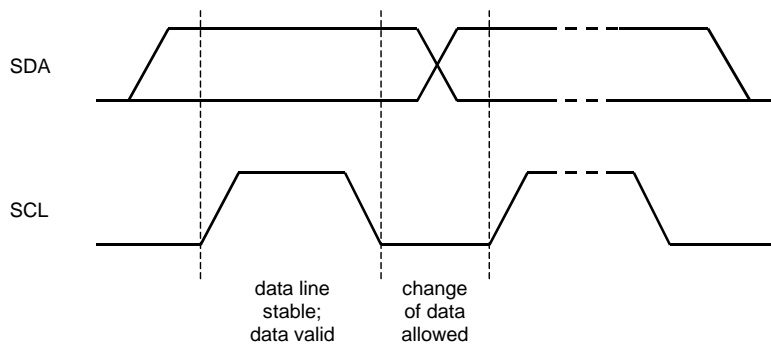

Figure 21. Bit transfer on the I<sup>2</sup>C-bus

## ■ Register Map

Addr	Register Name	D7	D6	D5	D4	D3	D2	D1	D0
00H	Control 1	ACKS	TDM1	TDM0	DIF2	DIF1	DIF0	PW1	RSTN
01H	Control 2	0	0	SLOW	DFS1	DFS0	DEM1	DEM0	SMUTE
02H	Control 3	PW4	PW3	PW2	0	0	DZFB	PW1	0
03H	LOUT1 ATT Control	ATT7	ATT6	ATT5	ATT4	ATT3	ATT2	ATT1	ATT0
04H	ROUT1 ATT Control	ATT7	ATT6	ATT5	ATT4	ATT3	ATT2	ATT1	ATT0
05H	LOUT2 ATT Control	ATT7	ATT6	ATT5	ATT4	ATT3	ATT2	ATT1	ATT0
06H	ROUT2 ATT Control	ATT7	ATT6	ATT5	ATT4	ATT3	ATT2	ATT1	ATT0
07H	LOUT3 ATT Control	ATT7	ATT6	ATT5	ATT4	ATT3	ATT2	ATT1	ATT0
08H	ROUT3 ATT Control	ATT7	ATT6	ATT5	ATT4	ATT3	ATT2	ATT1	ATT0
09H	LOUT4 ATT Control	ATT7	ATT6	ATT5	ATT4	ATT3	ATT2	ATT1	ATT0
0AH	ROUT4 ATT Control	ATT7	ATT6	ATT5	ATT4	ATT3	ATT2	ATT1	ATT0
0BH	Invert Output Signal	INVL1	INVR1	INVL2	INVR2	INVL3	INVR3	INVL4	INVR4
0CH	DZF1 Control	L1	R1	L2	R2	L3	R3	L4	R4
0DH	DZF2 Control	L1	R1	L2	R2	L3	R3	L4	R4
0EH	DEM Control	0	0	0	0	DEMA	DEMB	DEMC	DEMD

Note: For addresses from 0FH to 1FH, data must not be written.

When RSTB pin goes to “L”, the registers are initialized to their default values.

When RSTN bit goes to “0”, the only internal timing is reset, and the registers are not initialized to their default values. All data can be written to the registers even if PW1-4 bit or RSTN bit is “0”.

## ■ Register Definitions

Addr	Register Name	D7	D6	D5	D4	D3	D2	D1	D0
00H	Control 1	ACKS	TDM1	TDM0	DIF2	DIF1	DIF0	PW1	RSTN
	Default	1	0	0	0	1	0	1	1

RSTN: Internal timing reset

0: Reset. All DZF pins go to “H” and any registers are not initialized.

1: Normal operation

When MCLK frequency or DFS changes, the click noise can be reduced by RSTN bit.

PW1: Power-down control (0: Power-down, 1: Power-up)

PW1: Power down control of DAC1

This bit is duplicated into D1 of 02H.

DIF2-0: Audio data interface modes (See [Table 8](#), [Table 9](#), [Table 10](#))

Initial: “010”,

## TDM0-1: TDM Mode Select

Mode	TDM1	TDM0	BICK	SDTI	Sampling Speed
Normal	0	0	32fs~	1-4	Normal, Double, Quad Speed
TDM256	0	1	256fs fixed	1	Normal Speed
TDM128	1	1	128fs fixed	1-2	Normal, Double Speed

## ACKS: Master Clock Frequency Auto Setting Mode Enable

0: Disable, Manual Setting Mode

1: Enable, Auto Setting Mode

Master clock frequency is detected automatically at ACKS bit "1". In this case, the setting of DFS1-0 bits are ignored. When this bit is "0", DFS1-0 bits set the sampling speed mode.

Addr	Register Name	D7	D6	D5	D4	D3	D2	D1	D0
01H	Control 2	0	0	SLOW	DFS1	DFS0	DEM1	DEM0	SMUTE
	Default	0	0	0	0	0	0	1	0

## SMUTE: Soft Mute Enable

0: Normal operation

1: DAC outputs soft-muted

## DEM1-0: De-emphasis Response (See Table 11)

Initial: "01", OFF

## DFS1-0: Sampling speed control (See Table 1)

00: Normal speed

01: Double speed

10: Quad speed

When changing between Normal/Double Speed Mode and Quad Speed Mode, some click noise occurs.

## SLOW: Slow Roll-off Filter Enable

0: Sharp Roll-off Filter

1: Slow Roll-off Filter

Adr	Register Name	D7	D6	D5	D4	D3	D2	D1	D0
02H	Speed & Power Down Control	PW4	PW3	PW2	0	0	DZFB	PW1	0
	Default	1	1	1	0	0	0	1	0

## PW1: Power-down control (0: Power-down, 1: Power-up)

PW1: Power down control of DAC1

This bit is duplicated into D1 of 00H.

## DZFB: Inverting Enable of DZF

0: DZF goes "H" at Zero Detection

1: DZF goes "L" at Zero Detection

## PW4-2: Power-down control (0: Power-down, 1: Power-up)

PW2: Power down control of DAC2

PW3: Power down control of DAC3

PW4: Power down control of DAC4

All sections are powered-down by PW1=PW2=PW3=PW4=0.

Addr	Register Name	D7	D6	D5	D4	D3	D2	D1	D0
03H	LOUT1 ATT Control	ATT7	ATT6	ATT5	ATT4	ATT3	ATT2	ATT1	ATT0
04H	ROUT1 ATT Control	ATT7	ATT6	ATT5	ATT4	ATT3	ATT2	ATT1	ATT0
05H	LOUT2 ATT Control	ATT7	ATT6	ATT5	ATT4	ATT3	ATT2	ATT1	ATT0
06H	ROUT2 ATT Control	ATT7	ATT6	ATT5	ATT4	ATT3	ATT2	ATT1	ATT0
07H	LOUT3 ATT Control	ATT7	ATT6	ATT5	ATT4	ATT3	ATT2	ATT1	ATT0
08H	ROUT3 ATT Control	ATT7	ATT6	ATT5	ATT4	ATT3	ATT2	ATT1	ATT0
09H	LOUT4 ATT Control	ATT7	ATT6	ATT5	ATT4	ATT3	ATT2	ATT1	ATT0
0AH	ROUT4 ATT Control	ATT7	ATT6	ATT5	ATT4	ATT3	ATT2	ATT1	ATT0
Default		1	1	1	1	1	1	1	1

$ATT = 20 \log_{10} (ATT\_DATA / 255)$  [dB]

00H: Mute

Addr	Register Name	D7	D6	D5	D4	D3	D2	D1	D0
0BH	Invert Output Signal	INVL1	INVR1	INVL2	INVR2	INVL3	INVR3	INVL4	INVR4
Default		0	0	0	0	0	0	0	0

INVL4-1, INVR4-1: Inverting Output Polarity

0: Normal Output

1: Inverted Output

Addr	Register Name	D7	D6	D5	D4	D3	D2	D1	D0
0CH	DZF1 Control	L1	R1	L2	R2	L3	R3	L4	R4
0DH	DZF2 Control	L1	R1	L2	R2	L3	R3	L4	R4
Default		0	0	0	0	0	0	0	0

L1-4, R1-4: Zero Detect Flag Enable Bit for DZF1/2 pins

0: Disable

1: Enable

Addr	Register Name	D7	D6	D5	D4	D3	D2	D1	D0
0EH	DEM Control	0	0	0	0	DEMA	DEMB	DEMC	DEMD
Default		0	0	0	0	0	0	0	0

DEMA-D: De-emphasis Enable bit of DAC1/2/3/4

0: Disable

1: Enable

**SYSTEM DESIGN**

Figure 22 and Figure 23 show the system connection diagram. An evaluation board (AKD4359) is available which demonstrates application circuits, the optimum layout, power supply arrangements and measurement results.

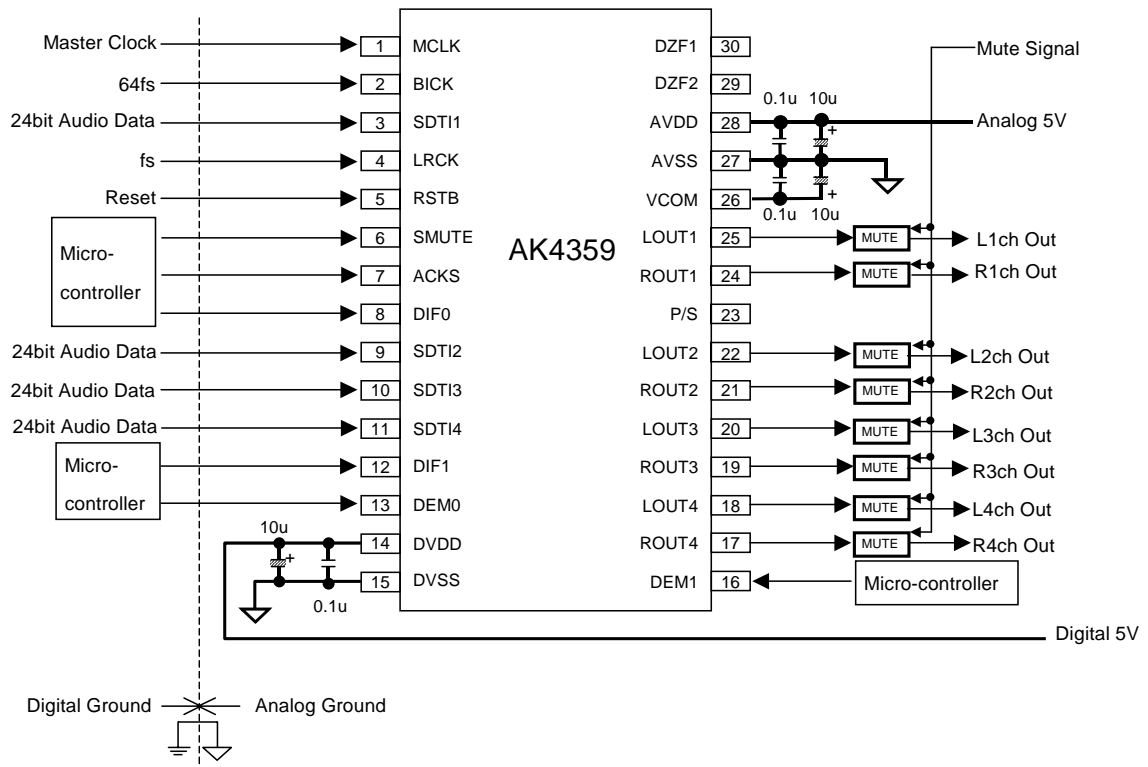

Figure 22. Typical Connection Diagram (Parallel Control Mode)

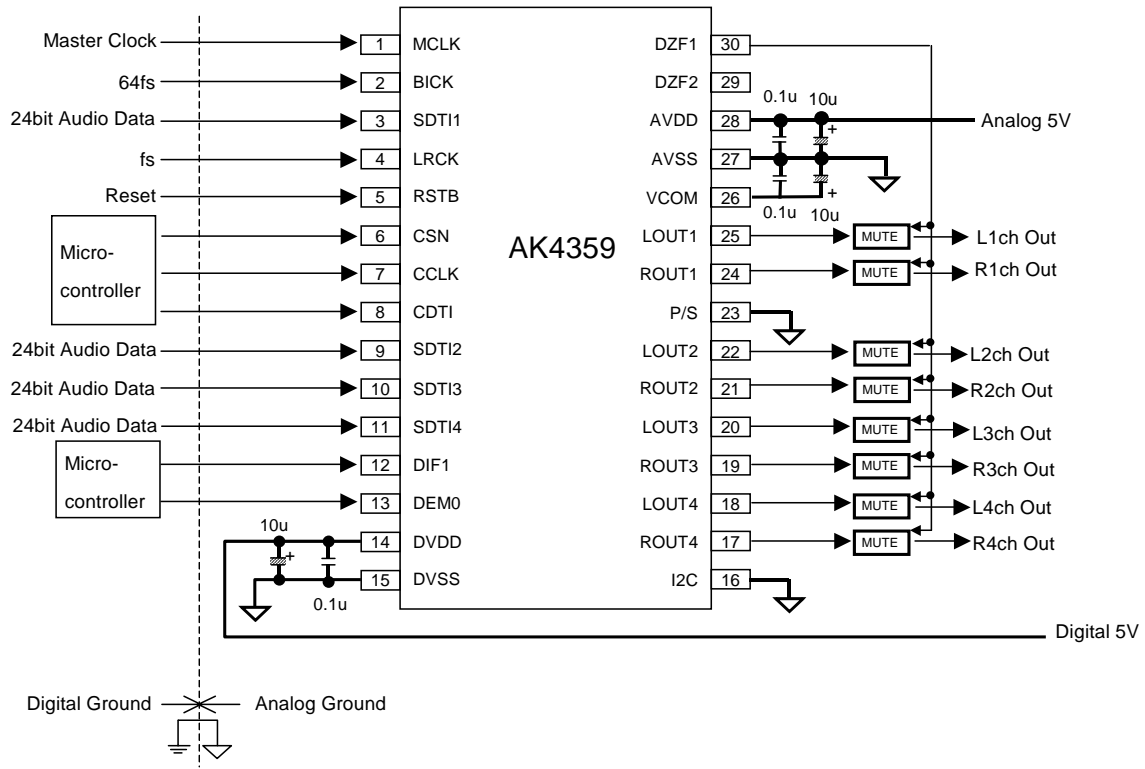

Figure 23. Typical Connection Diagram (3-wire Serial Control Mode)

Notes:

- LRCK = fs, BICK = 64fs.
- When AOUT drives some capacitive load, some resistor should be added in series between AOUT and capacitive load.
- All input pins except pull-up pin should not be left floating.

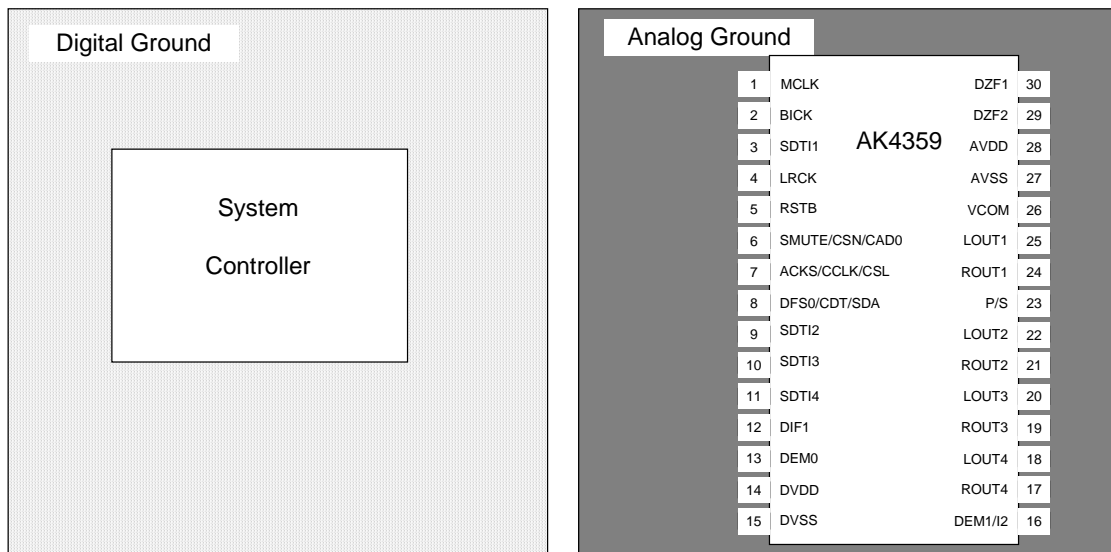

Figure 24. Ground Layout

AVSS and DVSS must be connected to the same analog ground plane.

## 1. Grounding and Power Supply Decoupling

AVDD and DVDD are usually supplied from analog supply in system and should be separated from system digital supply. Alternatively if AVDD and DVDD are supplied separately, the power up sequence is not critical. **AVSS and DVSS of the AK4359 must be connected to analog ground plane.** System analog ground and digital ground should be connected together near to where the supplies are brought onto the printed circuit board. Decoupling capacitor, especially 0.1 $\mu$ F ceramic capacitor for high frequency should be placed as near to AVDD and DVDD as possible.

## 2. Analog Outputs

The analog outputs are single-ended and centered around the VCOM voltage. The output signal range is typically 3.40V<sub>pp</sub> (typ@VDD=5V). The phase of the analog outputs can be inverted channel independently by INVL/INVR bits. The internal switched-capacitor filter and continuous-time filter attenuate the noise generated by the delta-sigma modulator beyond the audio passband. The input data format is 2's complement. The output voltage is a positive full scale for 7FFFFFFH (@24bit) and a negative full scale for 800000H (@24bit). The ideal output is VCOM voltage for 000000H (@24bit).

DC offsets on analog outputs are eliminated by AC coupling since analog outputs have DC offsets of VCOM + a few mV.

PACKAGE

30pin VSOP (Unit: mm)

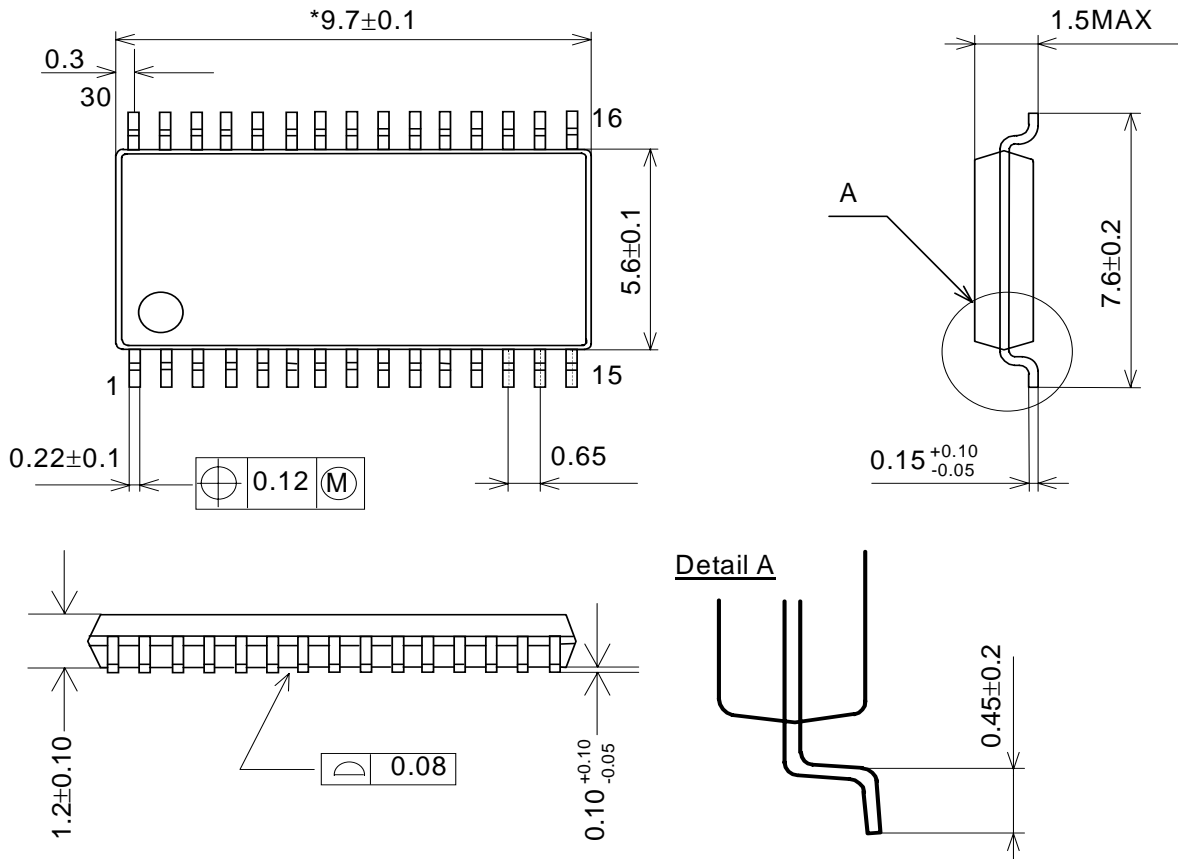

NOTE: Dimension "\*" does not include mold flash.

■ Package & Lead frame material

Package molding compound:	Epoxy
Lead frame material:	Cu
Lead frame surface treatment:	Solder (Pb free) plate

**MARKING**

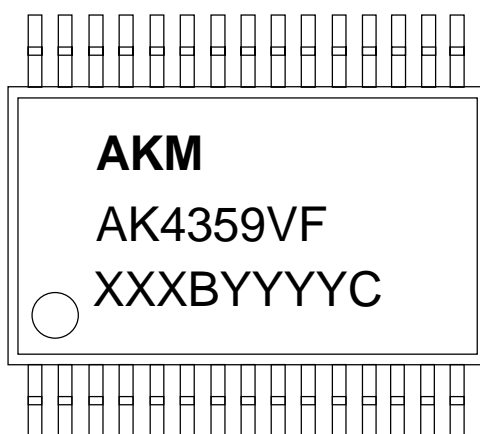

XXXBYYYYC    Date code identifier

XXXB :Lot number (X : Digit number, B : Alpha character)  
 YYYYYC : Assembly date (Y : Digit number, C : Alpha character)

**REVISION HISTORY**

Date (Y/M/D)	Revision	Reason	Page	Contents
04/02/03	00	First Edition		
05/11/29	01	Error Corrections	P20	<b>Power ON/OFF timing</b> Hi-Z → VCOM
			P22	<b>Register Control Interface</b> Table 14 Zero detection Parallel mode: O → X TDM mode is added.
			P28-30	<b>SYSTEM DESIGN</b> Figure 22, 23, 24 Pin #5; PDN → RSTB
06/03/15	02	Spec Cahge	8	<b>SWITCHING CHARACTERISTICS</b> <b>TDM256 mode (TDM0= “H”, TDM1= “L”)</b> tLRH (min): 1/256fs → 3/256fs tLRL (min): 1/256fs → 3/256fs  <b>TDM128 mode (TDM0= “H”, TDM1= “H”)</b> tLRH (min): 1/256fs → 3/256fs tLRL (min): 1/256fs → 3/256fs
			14	<b>Audio Serial Interface Format</b> “H” time and “L” time of LRCK should be 1/256fs at least. → “H” time and “L” time of LRCK should be 3/256fs at least.
			16	Figure 5,6,7 “H” time and “L” time of 3/256fs (min) was added in these timing diagrams.
			17	Figure 8,9,10 “H” time and “L” time of 3/256fs (min) was added in these timing diagrams.
11/02/18	03	Error Correction	7	<b>DC CHARACTERISTICS</b> Low-Level Output Voltage Descriptions of SDA pin were added.

**IMPORTANT NOTICE**

- These products and their specifications are subject to change without notice.  
When you consider any use or application of these products, please make inquiries the sales office of Asahi Kasei Microdevices Corporation (AKM) or authorized distributors as to current status of the products.
- Descriptions of external circuits, application circuits, software and other related information contained in this document are provided only to illustrate the operation and application examples of the semiconductor products. You are fully responsible for the incorporation of these external circuits, application circuits, software and other related information in the design of your equipments. AKM assumes no responsibility for any losses incurred by you or third parties arising from the use of these information herein. AKM assumes no liability for infringement of any patent, intellectual property, or other rights in the application or use of such information contained herein.
- Any export of these products, or devices or systems containing them, may require an export license or other official approval under the law and regulations of the country of export pertaining to customs and tariffs, currency exchange, or strategic materials.
- AKM products are neither intended nor authorized for use as critical components<sup>Note1)</sup> in any safety, life support, or other hazard related device or system<sup>Note2)</sup>, and AKM assumes no responsibility for such use, except for the use approved with the express written consent by Representative Director of AKM. As used here:
  - Note1) A critical component is one whose failure to function or perform may reasonably be expected to result, whether directly or indirectly, in the loss of the safety or effectiveness of the device or system containing it, and which must therefore meet very high standards of performance and reliability.
  - Note2) A hazard related device or system is one designed or intended for life support or maintenance of safety or for applications in medicine, aerospace, nuclear energy, or other fields, in which its failure to function or perform may reasonably be expected to result in loss of life or in significant injury or damage to person or property.
- It is the responsibility of the buyer or distributor of AKM products, who distributes, disposes of, or otherwise places the product with a third party, to notify such third party in advance of the above content and conditions, and the buyer or distributor agrees to assume any and all responsibility and liability for and hold AKM harmless from any and all claims arising from the use of said product in the absence of such notification.