

### GENERAL DESCRIPTION

AKD4614-A is an evaluation board for AK4614: 24bits, one-chip CODEC that includes six channels of ADC and twelve channels of DAC. AKD4614-A, it has the interface with the evaluation board of ADC and DAC of AKEMD's, so it is easy to evaluate A/D and D/A. And also, AKD4614-A, it has the digital audio interface, so it is available to achieve the interface with the equipments of digital audio systems, via RCA connectors.

### ■ Ordering guide

AKD4614-A -- AK4614 Evaluation Board

The 10-line flat cable to connect with the printer port of PC (IBM-AT compatible), the control software, and the drivers for Windows 2000/XP are packed with this. The control software does not work on Windows NT.

Windows 2000/XP requires the installation of the drivers.

Windows 95/98/ME does not require the installation of the drivers.

### FUNCTION

- Clock generate circuits (x2, use AK4114)
- 2 types of digital audio interface
  - RCA/Opt (S/PDIF) input/Output
  - 10pin headers (x2) for the interface with external equipments
- RCA connectors for the external clock inputs
- 10pin header for serial control (register control)

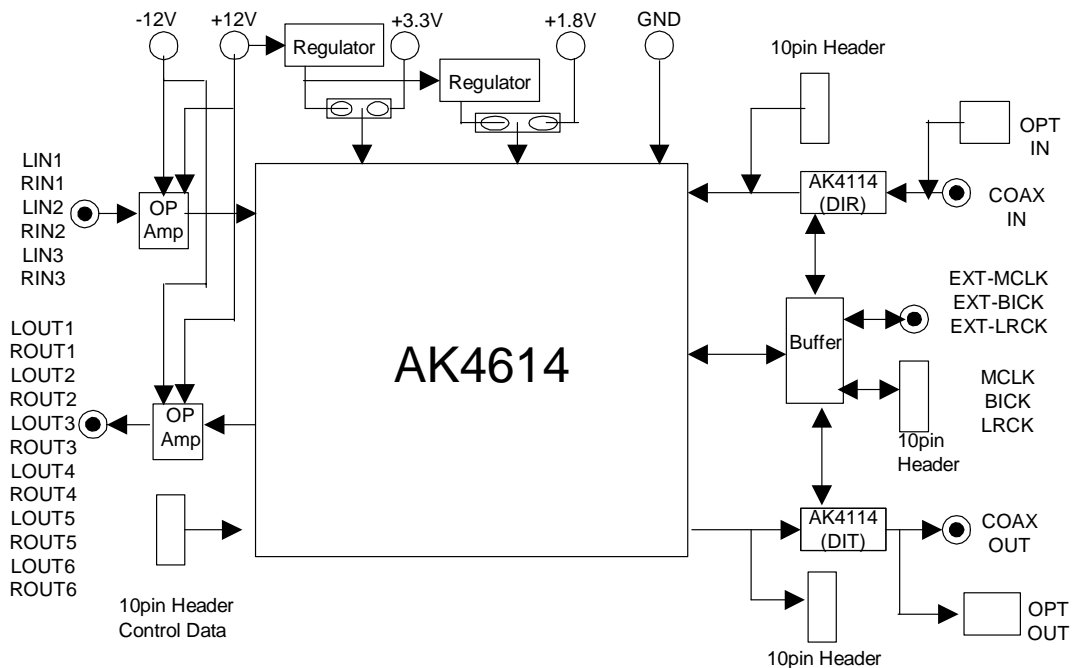

(Note) AK4114 includes DIR, DIT, X'tal Oscillator

Figure1. AKD4614-A Block Diagram (\*Circuit diagram and PCB layout are attached at the end of this manual.)

<b>Evaluation Board Manual</b>
--------------------------------

**■ Operation sequence****[1] The settings of the power supply lines****[2] The settings of the jumper pins****[3] The settings of the DIP switches****[4] The settings of the toggle switches****[5] The indications of the LEDs****[6] The register control (The serial control)****[7] The evaluation modes**

Refer to the following pages on the details.

**[1] The settings of the power supply lines**

Jack Names	Jack Colors	Voltage Ranges	Typ Voltages	Used for	Comments and attentions	Default Settings
VOP PLUS	Red	+9~+12V	+12V	The power supply of the regulator, The plus terminal of the power supply of the OPamp	Should be always connected.	+12V
VOP MINUS	Red	-9~-12V	-12V	The minus terminal of the power supply of the OPamp	Should be always connected.	-12V
AVDD1	Red	+3.0~+3.6V	+3.3V	AVDD1 of AK4614	When the regulator of 3.3V is used (JP99=REG side), this jack should be open.	Open
AVDD2	Red	+3.0~+3.6V	+3.3V	AVDD2 of AK4614	When the regulator of 3.3V is used (JP101=REG side), this jack should be open.	Open
TVDD1	Red	+1.6~+3.6V or +3.0~+3.6V (Note1)	+3.3V	TVDD1 of AK4614, The power supply of the level shifter	When the regulator of 3.3V is used (JP97=REG side), this jack should be open.	Open
TVDD2	Red	+1.6~+3.6V	+3.3V	AK4614: TVDD2, The power supply of the level shifter	When the regulator of 3.3V is used (JP98=REG side), this jack should be open.	Open
DVDD	Red	+1.6~+2.0V	+1.8V	DVDD of AK4614	When the regulator of 1.8V is used (JP96=REG side), this jack should be open.	Open
VDD	Red	+3.0~+3.6V	+3.3V	VDD of AK4114, The power supply of the level shifter, The power supply of the logic IC.	When the regulator of 3.3V is used (JP102=REG side), this jack should be open.	Open
AGND	Black	0V	0V	Analog ground	Should be always connected.	0V
DGND	Black	0V	0V	Digital ground	Should be always connected.	0V

Table 1. The settings of the power supply lines

Note 2. The voltage range of TVDD1 is +1.6~+3.6V on the Stereo Mode and the Normal Speed Mode, and +3.0~+3.6V on the other modes.

Note 3. The each supply lines should be distributed from the power supply units.

**[2] The settings of the jumper pins**

No	Names	Functions
99	AVDD1	The selection of the power supply to "AVDD1". REG: Regulator "T2". (Default) (When regulator "T2" is selected, power supply jack "AVDD1" should be open.) JACK: Power supply jack "AVDD1".
101	AVDD2	The selection of the power supply to "AVDD2". REG: Regulator "T2". (Default) (When regulator "T2" is selected, power supply jack "AVDD2" should be open.) JACK: Power supply jack "AVDD2".
97	TVDD1	The selection of the power supply to "TVDD1". REG: Regulator "T4". (Default) (When regulator "T4" is selected, power supply jack "TVDD1" should be open.) JACK: Power supply jack "TVDD1".
98	TVDD2	The selection of the power supply to "TVDD2". REG: Regulator "T4". (Default) (When regulator "T4" is selected, power supply jack "TVDD2" should be open.) JACK: Power supply jack "TVDD2".
96	DVDD	The selection of the power supply to "DVDD". REG: Regulator "T3". (Default) (When regulator "T3" is selected, power supply jack "DVDD" should be open.) JACK: Power supply jack "DVDD".
102	VDD	The selection of the power supply to "VDD". REG: Regulator "T4". (Default) (When regulator "T4" is selected, power supply jack "VDD" should be open.) JACK: Power supply jack "VDD".
100	GND	The selection of the connection / separation between analog ground and digital ground. Open: Separate analog ground from digital ground. (Default) Short: Connect analog ground to digital ground.
92	AK4614-4-wire / I2C	The selection of "4-wire Serial Mode" / "I2C Bus Mode" of AK4614 (U1). 4-wire: "4-wire Serial Mode". (Default) I2C: "I2C Bus Mode". When "4-wire Serial Mode" is selected, "CDTO" should be selected at JP93 at same time. And Set No.3 pin ("I2C") of DIP switch SW2 to "L" ("4-wire Serial Mode"). When "I2C Bus Mode" is selected, "SDA (ACK)" should be selected at JP93 at same time. And Set No.3 pin ("I2C") of DIP switch SW2 to "H" ("I2C Bus Mode").
93	CDTO / SDA (ACK)	The selection of "CDTO" ("4-wire Serial Mode") / "SDA (ACK)" ("I2C Bus Mode"). CDTO: "CDTO" ("4-wire Serial Mode"). (Default) SDA (ACK): "SDA (ACK)" ("I2C Bus Mode"). When "CDTO" ("4-wire Serial Mode") is selected, "4-wire Serial Mode" should be selected at JP92 at same time. And Set No.3 pin ("I2C") of DIP switch SW2 to "L" ("4-wire Serial Mode"). When "SDA (ACK)" ("I2C Bus Mode") is selected, "I2C Bus Mode" should be selected at JP92 at same time. And Set No.3 pin ("I2C") of DIP switch SW2 to "H" ("I2C Bus Mode").
65	AK4614-Master / Slave	The selection of the direction of signal flow adapted to "Master Mode" / "Slave Mode" of AK4614 (U1) at level shifter (U16). Master: Direction of the signal flow adapted to "Master Mode" of AK4614 (U1). Slave: Direction of the signal flow adapted to "Slave Mode" of AK4614 (U1).

		(Default) When "Master Mode" is selected, Set No.4 pin ("M/S") of DIP switch SW2 to "H" ("Master Mode"). When "Slave Mode" is selected, Set No.4 pin ("M/S") of DIP switch SW2 to "L" ("Slave Mode").
94	RX	The selection of the input to RX0 of DIR: AK4114 (U23). OPT: Optical connector. (Default). COAX: RCA connector (COAX).
95	TX	The selection of the output to TX1 of DIT: AK4114 (U26). OPT: Optical connector. (Default). COAX: RCA connector (COAX).
1	XTI / MCKI	The selection of the input to XTI / MCKI of AK4614 (U1). Open: No input. Short: MCLK-Buffer. (Default) When the setting of JP63 is except "open", and setting of JP1 is "short", remove X'tal: X1.
63	AK4614-XTI / MCKI	The selection of the input to buffer which outputs to XTI / MCKI of AK4614 (U1). BNC: EXT-MCLK. 10-pin: 10pin-MCLK. DIR: DIR-AK4114-MCKO1. DIT: DIT-AK4114-MCKO1. (Default) Open: No input. When the setting of JP63 is except "open", and setting of JP1 is "short", remove X'tal: X1.
64	AK4614-BICK	The selection of the input to buffer which outputs to BICK of AK4614 (U1). BNC: EXT-BICK. 10-pin: 10pin-BICK. DIR: DIR-AK4114-BICK. DIT: DIT-AK4114-BICK. (Default) Open: No input.
66	AK4614-LRCK	The selection of the input to buffer which outputs to LRCK of AK4614 (U1). BNC: EXT-LRCK. 10-pin: 10pin-LRCK. DIR: DIR-AK4114-LRCK. DIT: DIT-AK4114-LRCK. (Default) Open: No input.
67	DIR-AK4114-XTI	The selection of the input to buffer which outputs to XTI of DIR: AK4114 (U23). BNC: EXT-MCLK. 10-pin: 10pin-MCLK. CODEC: AK4614-MCKO-Buffer. DIT: DIT-AK4114-MCKO1. Open: No input. (Default) When the setting of JP67 is except "open", remove X'tal: X2.
70	DIR-AK4114-BICK	The selection of the input to buffer which outputs to BICK of DIR: AK4114 (U23). BNC: EXT-BICK. 10-pin: 10pin-BICK. CODEC: AK4614-BICK-Buffer. DIT: DIT-AK4114-BICK. (Default) Open: No input.
71	DIR-AK4114-LRCK	The selection of the input to buffer which outputs to LRCK of DIR: AK4114 (U23). BNC: EXT-LRCK. 10-pin: 10pin-LRCK. CODEC: AK4614-LRCK-Buffer.

		DIT: DIT-AK4114-LRCK. (Default) Open: No input.
73	DIT-AK4114-XTI	The selection of the input to buffer which outputs to XTI of DIT: AK4114 (U26). BNC: EXT-MCLK. 10-pin: 10pin-MCLK. CODEC: AK4614-MCKO-Buffer. DIR: DIR-AK4114-MCKO1. Open: No input. (Default) When the setting of JP73 is except "open", remove X'tal: X3.
75	DIT-AK4114-BICK	The selection of the input to buffer which outputs to BICK of DIT: AK4114 (U26). BNC: EXT-BICK. 10-pin: 10pin-BICK. CODEC: AK4614-BICK-Buffer. DIR: DIR-AK4114-BICK. Open: No input. (Default)
76	DIT-AK4114-LRCK	The selection of the input to buffer which outputs to LRCK of DIT: AK4114 (U26). BNC: EXT-LRCK. 10-pin: 10pin-LRCK. CODEC: AK4614-LRCK-Buffer. DIR: DIR-AK4114-LRCK. Open: No input. (Default)
68	GND	The selection of the termination of the input to EXT-MCLK. Open: No termination. Short: 51 to GND. (Default)
72	GND	The selection of the termination of the input to EXT-BICK. Open: No termination. Short: 51 to GND. (Default)
74	GND	The selection of the termination of the input to EXT-LRCK. Open: No termination. Short: 51 to GND. (Default)
69	BICK-THR / INV	The selection of the polarity (non-inverted output / inverted output) of 10pin-BICK outputs. THR: Non-inverted output. (Default) INV: Inverted output.
201	SDTI1	The selection of the input to SDTI1 of AK4614 (U1). DIR: DIR-AK4114-SDTO. (Default) 10pin: 10pin-SDTI1. GND: Digital ground.
202	SDTI2	The selection of the input to SDTI2 of AK4614 (U1). DIR: DIR-AK4114-SDTO. (Default) 10pin: 10pin-SDTI2. GND: Digital ground.
203	SDTI3	The selection of the input to SDTI3 of AK4614 (U1). DIR: DIR-AK4114-SDTO. (Default) 10pin: 10pin-SDTI3. GND: Digital ground.
204	SDTI4	The selection of the input to SDTI4 of AK4614 (U1). DIR: DIR-AK4114-SDTO. (Default) 10pin: 10pin-SDTI4. GND: Digital ground.
205	SDTI5	The selection of the input to SDTI5 of AK4614 (U1). DIR: DIR-AK4114-SDTO. (Default) 10pin: 10pin-SDTI5.

		GND: Digital ground.
206	SDTI6	The selection of the input to SDTI6 of AK4614 (U1). DIR: DIR-AK4114-SDTO. (Default) 10pin: 10pin-SDTI6. GND: Digital ground.
207	SDTO	The selection of the input to DAUX of DIT: AK4114 (U26). SDTO1: AK4614-SDTO1 / 10pin-SDTO1. (Default) SDTO2: AK4614-SDTO2 / 10pin-SDTO2. SDTO3: AK4614-SDTO3 / 10pin-SDTO3. Open: Connect a pin of DIT-AK4114-DAUX input side of JP207 to digital ground with the clip. Connect no signal.
2	LIN1 (LIN1+ / LIN1-)	The selection of the input to LIN1 (LIN1+ / LIN1-). SINGLE: LIN1 (Single-End). DIFF: LIN1 (Differential). (Default)
3	LIN1+ / LIN1	The selection of the input to LIN1+ / LIN1. SINGLE: LIN1 (Single-End). DIFF: LIN1+ (Differential). (Default)
4	LIN1-	The selection of the input to LIN1-. Open: None (Single-End). Short: LIN1- (Differential). (Default)
5	GND	The selection of the termination of the input to LIN1-. Short: GND (Single-End). Open: None (Differential). (Default)
6	RIN1 (RIN1+ / RIN1-)	The selection of the input to RIN1 (RIN1+ / RIN1-). SINGLE: RIN1 (Single-End). DIFF: RIN1 (Differential). (Default)
7	RIN1+ / RIN1	The selection of the input to RIN1+ / RIN1. SINGLE: RIN1 (Single-End). DIFF: RIN1+ (Differential). (Default)
8	RIN1-	The selection of the input to RIN1-. Open: None (Single-End). Short: RIN1- (Differential). (Default)
9	GND	The selection of the termination of the input to RIN1-. Short: GND (Single-End). Open: None (Differential). (Default)
10	LIN2 (LIN2+ / LIN2-)	The selection of the input to LIN2 (LIN2+ / LIN2-). SINGLE: LIN2 (Single-End). DIFF: LIN2 (Differential). (Default)
11	LIN2+ / LIN2	The selection of the input to LIN2+ / LIN2. SINGLE: LIN2 (Single-End). DIFF: LIN2+ (Differential). (Default)
12	LIN2-	The selection of the input to LIN2-. Open: None (Single-End). Short: LIN2- (Differential). (Default)
13	GND	The selection of the termination of the input to LIN2-. Short: GND (Single-End). Open: None (Differential). (Default)
14	RIN2 (RIN2+ / RIN2-)	The selection of the input to RIN2 (RIN2+ / RIN2-). SINGLE: RIN2 (Single-End). DIFF: RIN2 (Differential). (Default)
15	RIN2+ / RIN2	The selection of the input to RIN2+ / RIN2. SINGLE: RIN2 (Single-End). DIFF: RIN2+ (Differential). (Default)

16	RIN2-	The selection of the input to RIN2-. Open: None (Single-End). Short: RIN2- (Differential). (Default)
17	GND	The selection of the termination of the input to RIN2-. Short: GND (Single-End). Open: None (Differential). (Default)
18	LIN3 (LIN3+ / LIN3-)	The selection of the input to LIN3 (LIN3+ / LIN3-). SINGLE: LIN3 (Single-End). DIFF: LIN3 (Differential). (Default)
19	LIN3+ / LIN3	The selection of the input to LIN3+ / LIN3. SINGLE: LIN3 (Single-End). DIFF: LIN3+ (Differential). (Default)
20	LIN3-	The selection of the input to LIN3-. Open: None (Single-End). Short: LIN3- (Differential). (Default)
21	GND	The selection of the termination of the input to LIN3-. Short: GND (Single-End). Open: None (Differential). (Default)
22	RIN3 (RIN3+ / RIN3-)	The selection of the input to RIN3 (RIN3+ / RIN3-). SINGLE: RIN3 (Single-End). DIFF: RIN3 (Differential). (Default)
23	RIN3+ / RIN3	The selection of the input to RIN3+ / RIN3. SINGLE: RIN3 (Single-End). DIFF: RIN3+ (Differential). (Default)
24	RIN3-	The selection of the input to RIN3-. Open: None (Single-End). Short: RIN3- (Differential). (Default)
25	GND	The selection of the termination of the input to RIN3-. Short: GND (Single-End). Open: None (Differential). (Default)
26	VA	The selection of AIN-bias. Open: AIN-bias = 0V. Short: AIN-bias = $1/2 \times AVDD1 = 1/2 \times AVDD2$ . (Default)
27	LOUT1+ / LOUT1	The selection of the output from LOUT1+ / LOUT1. SINGLE: LOUT1 (Single-End). DIFF: LOUT1+ (Differential). (Default)
28	LOUT1-	The selection of the output from LOUT1-. Open: None (Single-End). Short: LOUT1- (Differential). (Default)
29	LOUT1	The selection of the output from LOUT1. SINGLE: LOUT1 (Single-End). DIFF: LOUT1 (Differential). (Default)
30	ROUT1+ / ROUT1	The selection of the output from ROUT1+ / ROUT1. SINGLE: ROUT1 (Single-End). DIFF: ROUT1+ (Differential). (Default)
31	ROUT1-	The selection of the output from ROUT1-. Open: None (Single-End). Short: ROUT1- (Differential). (Default)
32	ROUT1	The selection of the output from ROUT1. SINGLE: ROUT1 (Single-End). DIFF: ROUT1 (Differential). (Default)
33	LOUT2+ / LOUT2	The selection of the output from LOUT2+ / LOUT2. SINGLE: LOUT2 (Single-End).

		DIFF: LOUT2+ (Differential). (Default)
34	LOUT2-	The selection of the output from LOUT2-. Open: None (Single-End). Short: LOUT2- (Differential). (Default)
35	LOUT2	The selection of the output from LOUT2. SINGLE: LOUT2 (Single-End). DIFF: LOUT2 (Differential). (Default)
36	ROUT2+ / ROUT2	The selection of the output from ROUT2+ / ROUT2. SINGLE: ROUT2 (Single-End). DIFF: ROUT2+ (Differential). (Default)
37	ROUT2-	The selection of the output from ROUT2-. Open: None (Single-End). Short: ROUT2- (Differential). (Default)
38	ROUT2	The selection of the output from ROUT2. SINGLE: ROUT2 (Single-End). DIFF: ROUT2 (Differential). (Default)
39	LOUT3+ / LOUT3	The selection of the output from LOUT3+ / LOUT3. SINGLE: LOUT3 (Single-End). DIFF: LOUT3+ (Differential). (Default)
40	LOUT3-	The selection of the output from LOUT3-. Open: None (Single-End). Short: LOUT3- (Differential). (Default)
41	LOUT3	The selection of the output from LOUT3. SINGLE: LOUT3 (Single-End). DIFF: LOUT3 (Differential). (Default)
42	ROUT3+ / ROUT3	The selection of the output from ROUT3+ / ROUT3. SINGLE: ROUT3 (Single-End). DIFF: ROUT3+ (Differential). (Default)
43	ROUT3-	The selection of the output from ROUT3-. Open: None (Single-End). Short: ROUT3- (Differential). (Default)
44	ROUT3	The selection of the output from ROUT3. SINGLE: ROUT3 (Single-End). DIFF: ROUT3 (Differential). (Default)
45	LOUT4+ / LOUT4	The selection of the output from LOUT4+ / LOUT4. SINGLE: LOUT4 (Single-End). DIFF: LOUT4+ (Differential). (Default)
46	LOUT4-	The selection of the output from LOUT4-. Open: None (Single-End). Short: LOUT4- (Differential). (Default)
47	LOUT4	The selection of the output from LOUT4. SINGLE: LOUT4 (Single-End). DIFF: LOUT4 (Differential). (Default)
48	ROUT4+ / ROUT4	The selection of the output from ROUT4+ / ROUT4. SINGLE: ROUT4 (Single-End). DIFF: ROUT4+ (Differential). (Default)
49	ROUT4-	The selection of the output from ROUT4-. Open: None (Single-End). Short: ROUT4- (Differential). (Default)
50	ROUT4	The selection of the output from ROUT4. SINGLE: ROUT4 (Single-End). DIFF: ROUT4 (Differential). (Default)
51	LOUT5+ / LOUT5	The selection of the output from LOUT5+ / LOUT5.

		SINGLE: LOUT5 (Single-End). DIFF: LOUT5+ (Differential). (Default)
52	LOUT5-	The selection of the output from LOUT5-. Open: None (Single-End). Short: LOUT5- (Differential). (Default)
53	LOUT5	The selection of the output from LOUT5. SINGLE: LOUT5 (Single-End). DIFF: LOUT5 (Differential). (Default)
54	ROUT5+ / ROUT5	The selection of the output from ROUT5+ / ROUT5. SINGLE: ROUT5 (Single-End). DIFF: ROUT5+ (Differential). (Default)
55	ROUT5-	The selection of the output from ROUT5-. Open: None (Single-End). Short: ROUT5- (Differential). (Default)
56	ROUT5	The selection of the output from ROUT5. SINGLE: ROUT5 (Single-End). DIFF: ROUT5 (Differential). (Default)
57	LOUT6+ / LOUT6	The selection of the output from LOUT6+ / LOUT6. SINGLE: LOUT6 (Single-End). DIFF: LOUT6+ (Differential). (Default)
58	LOUT6-	The selection of the output from LOUT6-. Open: None (Single-End). Short: LOUT6- (Differential). (Default)
59	LOUT6	The selection of the output from LOUT6. SINGLE: LOUT6 (Single-End). DIFF: LOUT6 (Differential). (Default)
60	ROUT6+ / ROUT6	The selection of the output from ROUT6+ / ROUT6. SINGLE: ROUT6 (Single-End). DIFF: ROUT6+ (Differential). (Default)
61	ROUT6-	The selection of the output from ROUT6-. Open: None (Single-End). Short: ROUT6- (Differential). (Default)
62	ROUT6	The selection of the output from ROUT6. SINGLE: ROUT6 (Single-End). DIFF: ROUT6 (Differential). (Default)

Table 2. The settings of the jumper pins

### [3] The settings of the DIP switches

#### (1). The settings of SW1 (Settings of AK4614 (U1))

Set up the TEST pin (TEST1, TEST3, TEST4, TEST5 and TEST2) of AK4614 (U1) by SW1. About the setting of default, please refer to Table 3.

SW1 No.	Names	ON ("H")	OFF ("L")	Default
1	AK4614-TEST1	TEST pin Fixed to "L".		L
2	AK4614-TEST3			L
3	AK4614-TEST4			L
4	AK4614-TEST5			L
5	AK4614-TEST2			L
6	NC	N/A		L
7	NC			L
8	NC			L

Table 3. The settings of SW1

#### (2). The settings of SW2 (Settings of AK4614 (U1))

Set up the Chip Address Select (CAD1, CAD0), Serial Control Mode Select (4-wire Serial / I2C Bus), Master /Slave Mode Select and DAC output control (VCOM / Hi-z) of AK4614 (U1) by SW2. About the setting of default, please refer to Table 4.

SW2 No.	Names	ON ("H")	OFF ("L")	Default
1	CAD0	Chip Address Select		L
2	CAD1			L
3	I2C	Serial Control Mode Select L: 4-wire Serial (Default) H: I2C Bus		L
4	M/S	Master /Slave Mode Select L: Slave Mode (Default) H: Master Mode		L
5	DVMPD	DAC output control L: VCOM voltage (Default) H: Hi-z		L
6	NC	N/A		L
7	NC			L
8	NC			L

Table 4. The settings of SW2

### (3). The settings of SW4 (Settings of DIR: AK4114 (U23))

ON is “H”, OFF is “L”.

The setting of default (Slave mode, 24bit I2S Compatible) is as follows. (Please refer to Table 5.)

SW4 No.	Names	ON (“H”)	OFF (“L”)	Default
1	DIF2	AK4114 Output Audio Interface Format Setting Please refer to Table 6.		H
2	DIF1			H
3	DIF0			H
4	CM1	AK4114 Clock Mode Setting CM1=L, CM0=H: X’tal Mode CM1=L, CM0=L: PLL Mode (Default)		L
5	CM0			L
6	OCKS1	AK4114 Master Clock Frequency Setting Please refer to Table 7.		H
7	OCKS0			L
8	NC	N/A		L

Table 5. The settings of SW4

Mode	DIF2 pin	DIF1 pin	DIF0 pin	SDTO Formats	LRCK		BICK	
						I/O		I/O
0	L	L	L	16bit, Right justified	H/L	O	64fs	O
1	L	L	H	18bit, Right justified	H/L	O	64fs	O
2	L	H	L	20bit, Right justified	H/L	O	64fs	O
3	L	H	H	24bit, Right justified	H/L	O	64fs	O
4	H	L	L	24bit, Left justified	H/L	O	64fs	O
5	H	L	H	24bit, I <sup>2</sup> S Compatible	L/H	O	64fs	O
6	H	H	L	24bit, Left justified	H/L	I	64-128fs	I
7	H	H	H	24bit, I <sup>2</sup> S Compatible	L/H	I	64-128fs	I

(Default)

Table 6. The settings of AK4114 Output Audio Interface Formats

Mode	OCKS1 pin	OCKS0 pin	MCKO1	fs (max)
0	L	L	256fs	96 kHz
1	L	H	256fs	96 kHz
2	H	L	512fs	48 kHz
3	H	H	128fs	192 kHz

(Default)

Table 7. The settings of AK4114 Master Clock Frequencies

#### (4). The settings of SW6 (Settings of DIT: AK4114 (U26))

ON is “H”, OFF is “L”.

The setting of default (Master mode, 24bit I2S Compatible) is as follows. (Please refer to Table 8.)

SW5 No.	Names	ON (“H”)	OFF (“L”)	Default
1	DIF2	AK4114 Input Audio Interface Format Setting Please refer to Table 9.		H
2	DIF1			L
3	DIF0			H
4	CM1	AK4114 Clock Mode Setting CM1=L, CM0=H: X’tal Mode (Default) CM1=L, CM0=L: PLL Mode		L
5	CM0			H
6	OCKS1	AK4114 Master Clock Frequency Setting Please refer to Table 10.		H
7	OCKS0			L
8	NC	N/A		L

Table 8. The settings of SW6

Mode	DIF2 pin	DIF1 pin	DIF0 pin	DAUX Formats	LRCK		BICK	
						I/O		I/O
0	L	L	L	24bit, Left justified	H/L	O	64fs	O
1	L	L	H	24bit, Left justified	H/L	O	64fs	O
2	L	H	L	24bit, Left justified	H/L	O	64fs	O
3	L	H	H	24bit, Left justified	H/L	O	64fs	O
4	H	L	L	24bit, Left justified	H/L	O	64fs	O
5	H	L	H	24bit, I <sup>2</sup> S Compatible	L/H	O	64fs	O
6	H	H	L	24bit, Left justified	H/L	I	64-128fs	I
7	H	H	H	24bit, I <sup>2</sup> S Compatible	L/H	I	64-128fs	I

(Default)

Table 9. The settings of AK4114 Input Audio Interface Formats

Mode	OCKS1 pin	OCKS0 pin	MCKO1	fs (max)
0	L	L	256fs	96 kHz
1	L	H	256fs	96 kHz
2	H	L	512fs	48 kHz
3	H	H	128fs	192 kHz

(Default)

Table 10. The settings of AK4114 Master Clock Frequencies

#### [4] The settings of the toggle switches

##### The settings of SW3, SW5, SW7

SW3	PDN-AK4614	The power down switch of AK4614 (U1). AK4614 (U1) should be reset once bringing this “L” upon power-up. Keep “H” during normal operation.
SW5	PDN-DIR-AK4114	The power down switch of DIR: AK4114 (U23). DIR: AK4114 (U23) should be reset once bringing this “L” upon power-up. Keep “H” during normal operation. Keep “L” when DIR: AK4114 (U23) is not used.
SW7	PDN-DIT-AK4114	The power down switch of DIT: AK4114 (U26). DIT: AK4114 (U26) should be reset once bringing this “L” upon power-up. Keep “H” during normal operation. Keep “L” when DIT: AK4114 (U26) is not used.

Table 11. The settings of SW3, SW5, SW7

#### [5] The indications of the LEDs

##### The indication of LED1

LED1	INT0	The output of INT0 pin of the DIR: AK4114 (U23). Turns on when DIR: AK4114 (U23) is unlocked.
------	------	---

Table 12. The indication of LED1

#### [6] The register control (The serial control)

AKD4614-A can be controlled via the printer port (parallel port) of IBM-AT compatible PC. Connect PORT5 (uP-I/F) with PC by 10-wire flat cable packed with the AKD4614-A. Take care of the direction of the 10-pin connector and the 10-pin header. There is a mark on the no.1-pin of the 10-pin connector. Pin assignments of PORT5 are shown in Figure 2.

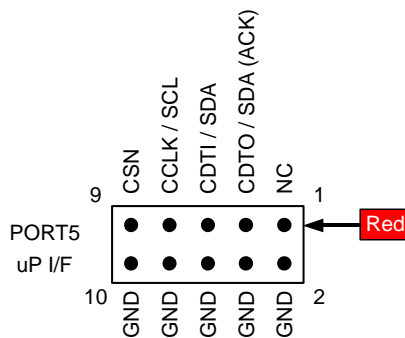

Figure 2. The pin assignments of PORT5

The control software is packed with the evaluation board. The software operation sequence is included in the evaluation board manual.

**[7] The evaluation modes**

- (1) The evaluation mode of ADC→DAC (Analog → Analog) by the internal loop back**
  - (1)-1. Master mode**
- (2) The evaluation mode of ADC→DAC (Analog → Analog) by the external loop back with the jumper pins or 10 pin header (10 pin port, 10 pin connector) and the clips**
  - (2)-1. Master mode**
- (3) The evaluation mode of ADC→DAC (Analog → Analog) by the external loop back with the external DIT: AK4114 (U26) and the external DIR: AK4114 (U23)**
  - (3)-1. Master mode**
  - (3)-2. Slave mode (Default)**
- (4) The evaluation mode of ADC (Analog → Digital) with the external DIT: AK4114 (U26)**
  - (4)-1. Master mode**
  - (4)-2. Slave mode**
- (5) The evaluation mode of DAC (Digital → Analog) with the external DIR: AK4114 (U23)**
  - (5)-1. Master mode**
  - (5)-2. Slave mode**
- (6) The evaluation mode of ADC (Analog → Digital) with the external clocks**
  - (6)-1. Slave mode**
- (7) The evaluation mode of DAC (Digital → Analog) with the external clocks**
  - (7)-1. Slave mode**

**(1) The evaluation mode of ADC→DAC (Analog → Analog) by the internal loop back**
**(1)-1. Master mode**

Devices (Parts)	Use	Not use	Removed	Clock sources			Modes	
				External clock	X'tal	PLL	Master	Slave
AK4614 (U1)		-	-	-		-		-
DIR: AK4114 (U23)	-		-	-	-	-	-	-
DIT: AK4114 (U26)	-		-	-	-	-	-	-
X'tal: X1		-	-	/			/	
X'tal: X2	-							
X'tal: X3	-							

Table 13. Use / Not use of the devices (parts) and the modes of using

Jumper pins Cables Connectors	OPT	COAX	Use	Not use	Destinations of the connections					
					PORT6 (RX: OPT)	PORT7 (TX: OPT)	J22 (RX: COAX)	J23 (TX: COAX)	External optical connector	External BNC connector
JP94 (RX)	-	-	/		/					
JP95 (TX)	-	-								
Optical cable										
BNC cable										
BNC-RCA conversion connector										
PORT6 (RX: OPT)			-		-	-	-	-	-	-
PORT7 (TX: OPT)			-		-	-	-	-	-	-
J22 (RX: COAX)			-		-	-	-	-	-	-
J23 (TX: COAX)			-		-	-	-	-	-	-

Table 14. Use / Not use of the jumper pins, cables, connectors and the destinations of the connections

Jumper pins	Master	Slave	Short	Open	CODEC	DIR	DIT	BNC	10-pin	Open
JP65 (AK4614-Master/Slave)		-	/		/					
JP1 (XTI/MCKI)										
JP63 (AK4614-XTI/MCKI)										
JP64 (AK4614-BICK)										
JP66 (AK4614-LRCK)										
JP67 (DIR-AK4114-XTI)										
JP70 (DIR-AK4114-BICK)										
JP71 (DIR-AK4114-LRCK)										
JP73 (DIT-AK4114-XTI)										
JP75 (DIT-AK4114-BICK)										
JP76 (DIT-AK4114-LRCK)										

Table 15. The settings of the jumper pins (modes and clocks)

JP207 (SDTO) should be open.

Jumper pins		SDTO1	SDTO2	SDTO3	Open	DIR	10-pin	GND	Open				
JP207 (SDTO)	Always	-	-		(Note1)								
JP201 (SDTI1)	Always									-	-		
JP202 (SDTI2)	Always									-	-		-
JP203 (SDTI3)	Always									-	-		-
JP204 (SDTI4)	Always									-	-		-
JP205 (SDTI5)	Always									-	-		-
JP206 (SDTI6)	Always									-	-		-

Table 16. The settings of the jumper pins (digital inputs / digital outputs)

(Note1) Connect DAUX side of DIT: AK4114 (U26) to GND by the clips.

Switch names	Pin No.	Signal names	Values	Functions
SW2 (MODE-AK4614)	4	M/S	H	Master Mode
SW4 (DIR-AK4114-MODE)	1	DIF2	H	Slave Mode, 24bit I2S Compatible
	2	DIF1	H	
	3	DIF0	H	
	4	CM1	L	X'tal Mode
	5	CM0	H	
SW6 (DIT-AK4114-MODE)	1	DIF2	H	Slave Mode, 24bit I2S Compatible
	2	DIF1	H	
	3	DIF0	H	
	4	CM1	L	X'tal Mode
	5	CM0	H	

Table 17. The settings of the DIP switches

Switch on the power supply units, and do the settings of the toggle switches as follows.

Switch names	Values	Functions
SW3 (PDN-AK4614)	L→H	Power down→Power up
SW5 (PDN-DIR-AK4114)	L	Power down
SW7 (PDN-DIT-AK4114)	L	Power down

Table 18. The settings of the toggle switches

Start up the control software, click “Write default” button, write the default value, and write the settings as follows. (The values except the settings as follows are default.)

Register addresses	Bits	Signal name	Values	Functions
08H	D7	LOOP1	0	Normal Operation→Loop Back Mode
08H	D6	LOOP0	0→1	

Table 19. The settings of the registers

The combinations of the settings of the registers and analog inputs / analog outputs paths are as follows.

Combinations	Settings of the registers	Analog inputs / analog outputs paths
1	LOOP1, LOOP0=0,1	LIN1→LOUT1, LOUT2 RIN1→ROUT1, ROUT2 LIN2→LOUT3, LOUT4 RIN2→ROUT3, ROUT4 LIN3→LOUT5, LOUT6 RIN3→ROUT5, ROUT6

Table 20. The combinations of the settings of the registers and analog inputs / analog outputs paths

**(2) The evaluation mode of ADC→DAC (Analog → Analog) by the external loop back with the jumper pins or 10 pin header (10 pin port, 10 pin connector) and the clips**

**(2)-1. Master mode**

Devices (Parts)	Use	Not use	Removed	Clock sources			Modes	
				External clock	X'tal	PLL	Master	Slave
AK4614 (U1)		-	-	-		-		-
DIR: AK4114 (U23)	-		-	-	-	-	-	-
DIT: AK4114 (U26)	-		-	-	-	-	-	-
X'tal: X1		-	-	/			/	
X'tal: X2	-							
X'tal: X3	-							

Table 21. Use / Not use of the devices (parts) and the modes of using

Jumper pins Cables Connectors	OPT	COAX	Use	Not use	Destinations of the connections										
					PORT6 (RX: OPT)	PORT7 (TX: OPT)	J22 (RX: COAX)	J23 (TX: COAX)	External optical connector	External BNC connector					
JP94 (RX)	-	-	/												
JP95 (TX)	-	-													
Optical cable															
BNC cable															
BNC-RCA conversion connector															
PORT6 (RX: OPT)										-	-	-	-	-	-
PORT7 (TX: OPT)										-	-	-	-	-	-
J22 (RX: COAX)										-	-	-	-	-	-
J23 (TX: COAX)			-	-	-	-	-	-							

Table 22. Use / Not use of the jumper pins, cables, connectors and the destinations of the connections

Jumper pins	Master	Slave	Short	Open	CODEC	DIR	DIT	BNC	10-pin	Open							
JP65 (AK4614-Master/Slave)		-	/														
JP1 (XTI/MCKI)											-						
JP63 (AK4614-XTI/MCKI)													-	-	-	-	-
JP64 (AK4614-BICK)													-	-	-	-	-
JP66 (AK4614-LRCK)													-	-	-	-	-
JP67 (DIR-AK4114-XTI)													-	-	-	-	-
JP70 (DIR-AK4114-BICK)													-	-	-	-	-
JP71 (DIR-AK4114-LRCK)													-	-	-	-	-
JP73 (DIT-AK4114-XTI)													-	-	-	-	-
JP75 (DIT-AK4114-BICK)													-	-	-	-	-
JP76 (DIT-AK4114-LRCK)					-	-	-	-	-								

Table 23. The settings of the jumper pins (modes and clocks)

Connect the jumper pins of digital outputs (3pins) and the jumper pins of digital inputs (6pins) by the clips.

Jumper pins of digital outputs (3pins)	Jumper pins of digital inputs (6pins)
(1) SDTO1 pin (U20 side pin of JP207 (SDTO))	(1) SDTI1 pin (U19 side pin of JP201 (SDTI1))
(2) SDTO2 pin (U20 side pin of JP207 (SDTO))	(2) SDTI2 pin (U19 side pin of JP202 (SDTI2))
(3) SDTO3 pin (U20 side pin of JP207 (SDTO))	(3) SDTI3 pin (U19 side pin of JP203 (SDTI3))
	(4) SDTI4 pin (U19 side pin of JP204 (SDTI4))
	(5) SDTI5 pin (U19 side pin of JP205 (SDTI5))
	(6) SDTI6 pin (U19 side pin of JP206 (SDTI6))

Table 24. The connections of the jumper pins by the clips (digital inputs / digital outputs)

JP207 (SDTO) should be open. JP201 (SDTI1), JP202 (SDTI2), JP203 (SDTI3), JP204 (SDTI4), JP205 (SDTI5), JP206 (SDTI6) should be open on signal input.

Jumper pins		SDTO1	SDTO2	SDTO3	Open	DIR	10-pin	GND	Open
JP207 (SDTO)	Always	-	-	-	(Note1)				
JP201 (SDTI1)	SDTI1 input	/	/	/	/	-	-	-	(Note2)
	No input					-	-	-	-
JP202 (SDTI2)	SDTI2 input					-	-	-	(Note2)
	No input					-	-	-	-
JP203 (SDTI3)	SDTI3 input					-	-	-	(Note2)
	No input					-	-	-	-
JP204 (SDTI4)	SDTI4 input					-	-	-	(Note2)
	No input					-	-	-	-
JP205 (SDTI5)	SDTI5 input					-	-	-	(Note2)
	No input					-	-	-	-
JP206 (SDTI6)	SDTI6 input					-	-	-	(Note2)
	No input					-	-	-	-

Table 25. The settings of the jumper pins (digital inputs / digital outputs)

(Note1) Connect DAUX side of DIT: AK4114 (U26) to GND by the clips.

(Note2) Connect the jumper pins of digital outputs (3pins) and the jumper pins of digital inputs (6pins) by the clips. (Please refer to Table 24. The connections of the jumper pins by the clips (digital inputs / digital outputs))

Switch names	Pin No.	Signal names	Values	Functions
SW2 (MODE-AK4614)	4	M/S	H	Master Mode
SW4 (DIR-AK4114-MODE)	1	DIF2	H	Slave Mode, 24bit I2S Compatible
	2	DIF1	H	
	3	DIF0	H	
	4	CM1	L	X'tal Mode
	5	CM0	H	
SW6 (DIT-AK4114-MODE)	1	DIF2	H	Slave Mode, 24bit I2S Compatible
	2	DIF1	H	
	3	DIF0	H	
	4	CM1	L	X'tal Mode
	5	CM0	H	

Table 26. The settings of the DIP switches

Switch on the power supply units, and do the settings of the toggle switches as follows.

Switch names	Values	Functions
SW3 (PDN-AK4614)	L→H	Power down→Power up
SW5 (PDN-DIR-AK4114)	L	Power down
SW7 (PDN-DIT-AK4114)	L	Power down

Table 27. The settings of the toggle switches

Starts up the control software, click “Write default” button, write the default value.

The combinations of the connections of the jumper pins by the clips and analog inputs / analog outputs paths are as follows.

Combinations	Connections of the jumper pins by the clips	Analog input / analog output paths
1	SDTO1→SDTI1, SDTI2 SDTO2→SDTI3, SDTI4 SDTO3→SDTI5, SDTI6	LIN1→LOUT1, LOUT2 RIN1→ROUT1, ROUT2 LIN2→LOUT3, LOUT4 RIN2→ROUT3, ROUT4 LIN3→LOUT5, LOUT6 RIN3→ROUT5, ROUT6
2	SDTO1→SDTI1 SDTO2→SDTI2 SDTO3→SDTI3	LIN1→LOUT1 RIN1→ROUT1 LIN2→LOUT2 RIN2→ROUT2 LIN3→LOUT3 RIN3→ROUT3
3	SDTO1→SDTI4 SDTO2→SDTI5 SDTO3→SDTI6	LIN1→LOUT4 RIN1→ROUT4 LIN2→LOUT5 RIN2→ROUT5 LIN3→LOUT6 RIN3→ROUT6
4	SDTO1→SDTI1, SDTI2, SDTI3, SDTI4, SDTI5, SDTI6	LIN1→LOUT1, LOUT2, LOUT3, LOUT4, LOUT5, LOUT6 RIN1→ROUT1, ROUT2, ROUT3, ROUT4, ROUT5, ROUT6

Table 28. The combinations of the connections of the jumper pins by the clips and analog inputs / analog outputs paths

**(3) The evaluation mode of ADC→DAC (Analog → Analog) by the external loop back with the external DIT: AK4114 (U26) and the external DIR: AK4114 (U23)**

**(3)-1. Master mode**

Devices (Parts)	Use	Not use	Removed	Clock sources			Modes	
				External clock	X'tal	PLL	Master	Slave
AK4614 (U1)		-	-	-		-		-
DIR: AK4114 (U23)		-	-	-	-		-	
DIT: AK4114 (U26)		-	-		-	-	-	
X'tal: X1		-	-	/			/	
X'tal: X2	-							
X'tal: X3	-							

Table 29. Use / Not use of the devices (parts) and the modes of using

**(a). In case of using optical cable and optical connector**

Jumper pins Cables Connectors	OPT	COAX	Use	Not use	Destinations of the connections									
					PORT6 (RX: OPT)	PORT7 (TX: OPT)	J22 (RX: COAX)	J23 (TX: COAX)	External optical connector	External BNC connector				
JP94 (RX)		-	/		/									
JP95 (TX)		-												
Optical cable														
BNC cable		-	-		/									
BNC-RCA conversion connector		-												
PORT6 (RX: OPT)			-	-							-	-	-	-
PORT7 (TX: OPT)			-	-							-	-	-	-
J22 (RX: COAX)			-	-							-	-	-	-
J23 (TX: COAX)			-	-							-	-	-	-

Table 30. Use / Not use of the jumper pins, cables, connectors and the destinations of the connections

**(b). In case of using BNC cable and BNC-RCA conversion connector and RCA connector**

Jumper pins Cables Connectors	OPT	COAX	Use	Not use	Destinations of the connections												
					PORT6 (RX: OPT)	PORT7 (TX: OPT)	J22 (RX: COAX)	J23 (TX: COAX)	External optical connector	External BNC connector							
JP94 (RX)	-		/	/	/												
JP95 (TX)	-																
Optical cable											-		/				
BNC cable												-					
BNC-RCA conversion connector												-					
PORT6 (RX: OPT)			-		-	-	-	-	-	-							
PORT7 (TX: OPT)			-		-	-	-	-	-	-							
J22 (RX: COAX)				-	-	-	-	-	-	-							
J23 (TX: COAX)				-	-	-	-	-	-	-							

Table 31. Use / Not use of the jumper pins, cables, connectors and the destinations of the connections

**(c). Other common setting**

Jumper pins	Master	Slave	Short	Open	CODEC	DIR	DIT	BNC	10-pin	Open							
JP65 (AK4614-Master/Slave)		-	/		/												
JP1 (XTI/MCKI)											-						
JP63 (AK4614-XTI/MCKI)													-	-	-	-	-
JP64 (AK4614-BICK)													-	-	-	-	-
JP66 (AK4614-LRCK)													-	-	-	-	-
JP67 (DIR-AK4114-XTI)													-	-	-	-	-
JP70 (DIR-AK4114-BICK)													-	-	-	-	-
JP71 (DIR-AK4114-LRCK)													-	-	-	-	-
JP73 (DIT-AK4114-XTI)													-	-	-	-	-
JP75 (DIT-AK4114-BICK)													-	-	-	-	-
JP76 (DIT-AK4114-LRCK)													-	-	-	-	-

Table 32. The settings of the jumper pins (modes and clocks)

Jumper pins		SDTO1	SDTO2	SDTO3	Open	DIR	10-pin	GND	Open				
JP207 (SDTO)	SDTO1 output		-	-	-								
	SDTO2 output	-		-	-								
	SDTO3 output	-	-		-								
JP201 (SDTI1)	SDTI1 input										-	-	-
	No input									-	-	-	
JP202 (SDTI2)	SDTI2 input										-	-	-
	No input									-	-	-	
JP203 (SDTI3)	SDTI3 input										-	-	-
	No input									-	-	-	
JP204 (SDTI4)	SDTI4 input										-	-	-
	No input					-	-	-					
JP205 (SDTI5)	SDTI5 input						-	-	-				
	No input					-	-	-					
JP206 (SDTI6)	SDTI6 input						-	-	-				
	No input					-	-	-					

Table 33. The settings of the jumper pins (digital inputs / digital outputs)

Switch names	Pin No.	Signal names	Values	Functions
SW2 (MODE-AK4614)	4	M/S	H	Master Mode
SW4 (DIR-AK4114-MODE)	1	DIF2	H	Slave Mode, 24bit I2S Compatible
	2	DIF1	H	
	3	DIF0	H	
	4	CM1	L	PLL Mode
	5	CM0	L	
SW6 (DIT-AK4114-MODE)	1	DIF2	H	Slave Mode, 24bit I2S Compatible
	2	DIF1	H	
	3	DIF0	H	
	4	CM1	L	X'tal Mode
	5	CM0	H	

Table 34. The settings of the DIP switches

Switch on the power supply units, and do the settings of the toggle switches as follows.

Switch names	Values	Functions
SW3 (PDN-AK4614)	L→H	Power down→Power up
SW5 (PDN-DIR-AK4114)	L→H	Power down→Power up
SW7 (PDN-DIT-AK4114)	L→H	Power down→Power up

Table 35. The settings of the toggle switches

Start up the control software, click “Write default” button, write the default value, and write the settings as follows. (The values except the settings as follows are default.)

Register addresses	Bits	Signal names	Values	Functions
04H	D6	MCKO	0→1	MCKO: no signal→ MCLK output

Table 36. The settings of the registers

The combinations of the settings of the jumper pins and analog inputs / analog outputs paths are as follows.

Combinations	Settings of the jumper pins	Analog inputs / analog outputs paths
1	JP207 (SDTO)=SDTO1 JP201 (SDTI1)=DIR JP202 (SDTI2)=DIR JP203 (SDTI3)= DIR JP204 (SDTI4)= DIR JP205 (SDTI5)= DIR JP206 (SDTI6)= DIR	LIN1→LOUT1, LOUT2, LOUT3, LOUT4, LOUT5, LOUT6 RIN1→ROUT1, ROUT2, ROUT3, ROUT4, ROUT5, ROUT6

Table 37. The combinations of the settings of the jumper pins and analog inputs / analog outputs paths

**(3)-2. Slave mode (Default)**

Devices (Parts)	Use	Not use	Removed	Clock sources			Modes	
				External clock	X'tal	PLL	Master	Slave
AK4614 (U1)		-	-		-	-	-	
DIR: AK4114 (U23)		-	-	-	-		-	
DIT: AK4114 (U26)		-	-	-		-		-
X'tal: X1	-			/			/	
X'tal: X2	-							
X'tal: X3		-	-					

Table 38. Use / Not use of devices (parts) and the modes of using

**(a). In case of using optical cable and optical connector**

Jumper pins Cables Connectors	OPT	COAX	Use	Not use	Destinations of the connections					
					PORT6 (RX: OPT)	PORT7 (TX: OPT)	J22 (RX: COAX)	J23 (TX: COAX)	External optical connector	External BNC connector
JP94 (RX)		-			/					
JP95 (TX)		-								
Optical cable				-						
BNC cable				-	/					
BNC-RCA conversion connector				-						
PORT6 (RX: OPT)				-						
PORT7 (TX: OPT)				-	-	-	-	-	-	
J22 (RX: COAX)				-	-	-	-	-	-	
J23 (TX: COAX)				-	-	-	-	-	-	

Table 39. Use / Not use of the jumper pins, cables, connectors and the destinations of the connections

**(b). In case of using BNC cable and BNC-RCA conversion connector and RCA connector**

Jumper pins Cables Connectors	OPT	COAX	Use	Not use	Destinations of the connections											
					PORT6 (RX: OPT)	PORT7 (TX: OPT)	J22 (RX: COAX)	J23 (TX: COAX)	External optical connector	External BNC connector						
JP94 (RX)	-		/	/	/											
JP95 (TX)	-															
Optical cable											-	-	/			
BNC cable											-	-				
BNC-RCA conversion connector											-	-				
PORT6 (RX: OPT)			-	-	-	-	-	-	-							
PORT7 (TX: OPT)			-	-	-	-	-	-	-							
J22 (RX: COAX)			-	-	-	-	-	-	-							
J23 (TX: COAX)			-	-	-	-	-	-	-							

Table 40. Use / Not use of the jumper pins, cables, connectors and the destinations of the connections

**(c). Other common setting**

Jumper pins	Master	Slave	Short	Open	CODEC	DIR	DIT	BNC	10-pin	Open
JP65 (AK4614-Master/Slave)	-		/		/					
JP1 (XTI/MCKI)										
JP63 (AK4614-XTI/MCKI)	/	/	/	/	-	-	-	-	-	-
JP64 (AK4614-BICK)					-	-	-	-	-	
JP66 (AK4614-LRCK)					-	-	-	-	-	
JP67 (DIR-AK4114-XTI)					-	-	-	-	-	
JP70 (DIR-AK4114-BICK)					-	-	-	-	-	
JP71 (DIR-AK4114-LRCK)					-	-	-	-	-	
JP73 (DIT-AK4114-XTI)					-	-	-	-	-	
JP75 (DIT-AK4114-BICK)					-	-	-	-	-	
JP76 (DIT-AK4114-LRCK)					-	-	-	-	-	

Table 41. The settings of the jumper pins (modes and clocks)

Jumper pins		SDTO1	SDTO2	SDTO3	Open	DIR	10-pin	GND	Open				
JP207 (SDTO)	SDTO1 output	-	-	-	-								
	SDTO2 output	-	-	-	-								
	SDTO3 output	-	-	-	-								
JP201 (SDTI1)	SDTI1 input									-	-	-	-
	No input									-	-	-	-
JP202 (SDTI2)	SDTI2 input									-	-	-	-
	No input									-	-	-	-
JP203 (SDTI3)	SDTI3 input									-	-	-	-
	No input									-	-	-	-
JP204 (SDTI4)	SDTI4 input									-	-	-	-
	No input					-	-	-	-				
JP205 (SDTI5)	SDTI5 input					-	-	-	-				
	No input					-	-	-	-				
JP206 (SDTI6)	SDTI6 input					-	-	-	-				
	No input					-	-	-	-				

Table 42. The settings of the jumper pins (digital inputs / digital outputs)

Switch names	Pin No.	Signal names	Values	Functions
SW2 (MODE-AK4614)	4	M/S	L	Slave Mode
SW4 (DIR-AK4114-MODE)	1	DIF2	H	Slave Mode, 24bit I2S Compatible
	2	DIF1	H	
	3	DIF0	H	PLL Mode
	4	CM1	L	
	5	CM0	L	
SW6 (DIT-AK4114-MODE)	1	DIF2	H	Master Mode, 24bit I2S Compatible
	2	DIF1	L	
	3	DIF0	H	
	4	CM1	L	X'tal Mode
	5	CM0	H	

Table 43. The settings of the DIP switches

Switch on the power supply unit, and do the setting of the toggle switches as follows.

Switch names	Values	Functions
SW3 (PDN-AK4614)	L→H	Power down→Power up
SW5 (PDN-DIR-AK4114)	L→H	Power down→Power up
SW7 (PDN-DIT-AK4114)	L→H	Power down→Power up

Table 44. The settings of the toggle switches

Starts up the control software, click “Write default” button, write the default value.

The combinations of the settings of the jumper pins and analog inputs / analog outputs paths are as follows.

Combinations	Settings of the jumper pins	Analog inputs / analog outputs paths
1	JP207 (SDTO)=SDTO1 JP201 (SDTI1)=DIR JP202 (SDTI2)=DIR JP203 (SDTI3)= DIR JP204 (SDTI4)= DIR JP205 (SDTI5)= DIR JP206 (SDTI6)= DIR	LIN1 → LOUT1, LOUT2, LOUT3, LOUT4, LOUT5, LOUT6 RIN1 → ROUT1, ROUT2, ROUT3, ROUT4, ROUT5, ROUT6

Table 45. The combinations of the settings of the jumper pins and analog inputs / analog outputs paths

**(4) The evaluation mode of ADC (Analog → Digital) with the external DIT: AK4114 (U26)**
**(4)-1. Master mode**

Devices (Parts)	Use	Not use	Removed	Clock sources			Modes	
				External clock	X'tal	PLL	Master	Slave
AK4614 (U1)		-	-	-		-		-
DIR: AK4114 (U23)	-		-	-	-	-	-	-
DIT: AK4114 (U26)		-	-		-	-	-	
X'tal: X1		-	-	/			/	
X'tal: X2	-							
X'tal: X3	-							

Table 46. Use / Not use of the devices (parts) and the modes of using

**(a). In case of using optical cable and optical connector**

Jumper pins Cables Connectors	OPT	COAX	Use	Not use	Destinations of the connections					
					PORT6 (RX: OPT)	PORT7 (TX: OPT)	J22 (RX: COAX)	J23 (TX: COAX)	External optical connector	External BNC connector
JP94 (RX)	-	-	/		/					
JP95 (TX)		-								
Optical cable	/			-	/					
BNC cable			-							
BNC-RCA conversion connector			-							
PORT6 (RX: OPT)			-							
PORT7 (TX: OPT)			-		-	-	-	-	-	
J22 (RX: COAX)	-		-		-	-	-	-	-	
J23 (TX: COAX)	-		-		-	-	-	-	-	

Table 47. Use / Not use of the jumper pins, cables, connectors and the destinations of the connections

**(b). In case of using BNC cable and BNC-RCA conversion connector and RCA connector**

Jumper pins Cables Connectors	OPT	COAX	Use	Not use	Destinations of the connections					
					PORT6 (RX: OPT)	PORT7 (TX: OPT)	J22 (RX: COAX)	J23 (TX: COAX)	External optical connector	External BNC connector
JP94 (RX)	-	-								
JP95 (TX)	-									
Optical cable			-							
BNC cable				-						
BNC-RCA conversion connector				-						
PORT6 (RX: OPT)			-							
PORT7 (TX: OPT)	-		-		-	-	-	-	-	-
J22 (RX: COAX)			-		-	-	-	-	-	-
J23 (TX: COAX)				-	-	-	-	-	-	-

Table 48. Use / Not use of the jumper pins, cables, connectors and the destinations of the connections

**(c). Other common setting**

Jumper pins	Master	Slave	Short	Open	CODEC	DIR	DIT	BNC	10-pin	Open
JP65 (AK4614-Master/Slave)		-								
JP1 (XTI/MCKI)										
JP63 (AK4614-XTI/MCKI)					-	-	-	-	-	
JP64 (AK4614-BICK)					-	-	-	-	-	
JP66 (AK4614-LRCK)					-	-	-	-	-	
JP67 (DIR-AK4114-XTI)					-	-	-	-	-	
JP70 (DIR-AK4114-BICK)					-	-	-	-	-	
JP71 (DIR-AK4114-LRCK)					-	-	-	-	-	
JP73 (DIT-AK4114-XTI)					-	-	-	-	-	-
JP75 (DIT-AK4114-BICK)					-	-	-	-	-	-
JP76 (DIT-AK4114-LRCK)					-	-	-	-	-	-

Table 49. The settings of the jumper pins (modes and clocks)

Jumper pins		SDTO1	SDTO2	SDTO3	Open	DIR	10-pin	GND	Open			
JP207 (SDTO)	SDTO1 output		-	-	-							
	SDTO2 output	-		-	-							
	SDTO3 output	-	-		-							
JP201 (SDTI1)	Always											
JP202 (SDTI2)	Always											
JP203 (SDTI3)	Always											
JP204 (SDTI4)	Always											
JP205 (SDTI5)	Always											
JP206 (SDTI6)	Always											

Table 50. The settings of the jumper pins (digital inputs / digital outputs)

Switch names	Pin No.	Signal names	Values	Functions
SW2 (MODE-AK4614)	4	M/S	H	Master Mode
SW4 (DIR-AK4114-MODE)	1	DIF2	H	Slave Mode, 24bit I2S Compatible
	2	DIF1	H	
	3	DIF0	H	
	4	CM1	L	X'tal Mode
	5	CM0	H	
SW6 (DIT-AK4114-MODE)	1	DIF2	H	Slave Mode, 24bit I2S Compatible
	2	DIF1	H	
	3	DIF0	H	
	4	CM1	L	X'tal Mode
	5	CM0	H	

Table 51. The settings of the DIP switches

Switch on the power supply units, and do the settings of the toggle switches as follows.

Switch names	Values	Functions
SW3 (PDN-AK4614)	L→H	Power down→Power up
SW5 (PDN-DIR-AK4114)	L	Power down
SW7 (PDN-DIT-AK4114)	L→H	Power down→Power up

Table 52. The settings of the toggle switches

Start up the control software, click “Write default” button, write the default value, and write the settings as follows. (The values except the settings as follows are default.)

Register addresses	Bits	Signal names	Values	Functions
04H	D6	MCKO	0→1	MCKO: no signal→ MCLK output

Table 53. The settings of the registers

The combinations of the settings of the jumper pins and analog inputs / digital outputs paths are as follows.

Combinations	Settings of the jumper pins	Analog inputs / digital outputs paths
1	JP207 (SDTO)=SDTO1	LIN1→SDTO1-Lch RIN1→SDTO1-Rch
2	JP207 (SDTO)=SDTO2	LIN2→SDTO2-Lch RIN2→SDTO2-Rch
3	JP207 (SDTO)=SDTO3	LIN3→SDTO3-Lch RIN3→SDTO3-Rch

Table 54. The combinations of the settings of the jumper pins and analog inputs / digital outputs paths

**(4)-2. Slave mode**

Devices (Parts)	Use	Not use	Removed	Clock sources			Modes	
				External clock	X'tal	PLL	Master	Slave
AK4614 (U1)		-	-		-	-	-	
DIR: AK4114 (U23)	-		-	-	-	-	-	-
DIT: AK4114 (U26)		-	-	-		-		-
X'tal: X1	-			/			/	
X'tal: X2	-							
X'tal: X3		-	-					

Table 55. Use / Not use of the devices (parts) and the modes of using

**(a). In case of using optical cable and optical connector**

Jumper pins Cables Connectors	OPT	COAX	Use	Not use	Destinations of the connections					
					PORT6 (RX: OPT)	PORT7 (TX: OPT)	J22 (RX: COAX)	J23 (TX: COAX)	External optical connector	External BNC connector
JP94 (RX)	-	-	/		/					
JP95 (TX)		-								
Optical cable	/			-	/					
BNC cable			-							
BNC-RCA conversion connector			-							
PORT6 (RX: OPT)			-							
PORT7 (TX: OPT)			-		-	-	-	-	-	
J22 (RX: COAX)	-		-		-	-	-	-	-	
J23 (TX: COAX)	-		-		-	-	-	-	-	

Table 56. Use / Not use of the jumper pins, cables, connectors and the destinations of the connections

**(b). In case of using BNC cable and BNC-RCA conversion connector and RCA connector**

Jumper pins Cables Connectors	OPT	COAX	Use	Not use	Destinations of the connections						
					PORT6 (RX: OPT) OPT)	PORT7 (TX: OPT) OPT)	J22 (RX: COAX) COAX)	J23 (TX: COAX) COAX)	External optical connector	External BNC connector	
JP94 (RX)	-	-	/		/						
JP95 (TX)	-										
Optical cable				-							
BNC cable											-
BNC-RCA conversion connector											-
PORT6 (RX: OPT)			-		-	-	-	-	-	-	
PORT7 (TX: OPT)			-		-	-	-	-	-	-	
J22 (RX: COAX)			-		-	-	-	-	-	-	
J23 (TX: COAX)				-	-	-	-	-	-	-	

Table 57. Use / Not use of the jumper pins, cables, connectors and the destinations of the connections

**(c). Other common setting**

Jumper pins	Master	Slave	Short	Open	CODEC	DIR	DIT	BNC	10-pin	Open
JP65 (AK4614-Master/Slave)	-		/		/					
JP1 (XTI/MCKI)										
JP63 (AK4614-XTI/MCKI)	/	/	/	/	-	-		-	-	-
JP64 (AK4614-BICK)					-	-		-	-	-
JP66 (AK4614-LRCK)					-	-		-	-	-
JP67 (DIR-AK4114-XTI)					-	-	-	-	-	-
JP70 (DIR-AK4114-BICK)					-	-	-	-	-	-
JP71 (DIR-AK4114-LRCK)					-	-	-	-	-	-
JP73 (DIT-AK4114-XTI)					-	-	-	-	-	-
JP75 (DIT-AK4114-BICK)					-	-	-	-	-	-
JP76 (DIT-AK4114-LRCK)					-	-	-	-	-	-

Table 58. The settings of the jumper pins (modes and clocks)

Jumper pins		SDTO1	SDTO2	SDTO3	Open	DIR	10-pin	GND	Open
JP207 (SDTO)	SDTO1 output		-	-	-				
	SDTO2 output	-		-	-				
	SDTO3 output	-	-		-				
JP201 (SDTI1)	Always					-	-		-
JP202 (SDTI2)	Always					-	-		-
JP203 (SDTI3)	Always					-	-		-
JP204 (SDTI4)	Always					-	-		-
JP205 (SDTI5)	Always					-	-		-
JP206 (SDTI6)	Always					-	-		-

Table 59. The settings of the jumper pins (digital inputs / digital outputs)

Switch names	Pin No.	Signal names	Values	Functions
SW2 (MODE-AK4614)	4	M/S	L	Slave Mode
SW4 (DIR-AK4114-MODE)	1	DIF2	H	Slave Mode, 24bit I2S Compatible
	2	DIF1	H	
	3	DIF0	H	
	4	CM1	L	X'tal Mode
	5	CM0	H	
SW6 (DIT-AK4114-MODE)	1	DIF2	H	Master Mode, 24bit I2S Compatible
	2	DIF1	L	
	3	DIF0	H	
	4	CM1	L	X'tal Mode
	5	CM0	H	

Table 60. The settings of the DIP switches

Switch on the power supply units, and do the settings of the toggle switches as follows.

Switch names	Values	Functions
SW3 (PDN-AK4614)	L→H	Power down→Power up
SW5 (PDN-DIR-AK4114)	L	Power down
SW7 (PDN-DIT-AK4114)	L→H	Power down→Power up

Table 61. The settings of the toggle switches

Starts up the control software, click “Write default” button, write the default value.

The combinations of the settings of the jumper pins and analog inputs / digital outputs paths are as follows.

Combinations	Settings of the jumper pins	Analog inputs / digital outputs paths
1	JP207 (SDTO)=SDTO1	LIN1→SDTO1-Lch RIN1→SDTO1-Rch
2	JP207 (SDTO)=SDTO2	LIN2→SDTO2-Lch RIN2→SDTO2-Rch
3	JP207 (SDTO)=SDTO3	LIN3→SDTO3-Lch RIN3→SDTO3-Rch

Table 62. The combinations of the settings of the jumper pins and analog inputs / digital outputs paths

**(5) The evaluation mode of DAC (Digital → Analog) with the external DIR: AK4114 (U23)**
**(5)-1. Master mode**

Devices (Parts)	Use	Not use	Removed	Clock sources			Modes	
				External clock	X'tal	PLL	Master	Slave
AK4614 (U1)		-	-		-	-		-
DIR: AK4114 (U23)		-	-	-	-		-	
DIT: AK4114 (U26)	-		-	-	-	-	-	-
X'tal: X1	-			/			/	
X'tal: X2	-							
X'tal: X3	-							

Table 63. Use / Not use of the devices (parts) and the modes of using

**(a). In case of using optical cable and optical connector**

Jumper pins Cables Connectors	OPT	COAX	Use	Not use	Destinations of the connections									
					PORT6 (RX: OPT)	PORT7 (TX: OPT)	J22 (RX: COAX)	J23 (TX: COAX)	External optical connector	External BNC connector				
JP94 (RX)		-	/		/									
JP95 (TX)	-	-												
Optical cable														
BNC cable					/									
BNC-RCA conversion connector														
PORT6 (RX: OPT)			-	-							-	-	-	-
PORT7 (TX: OPT)	-		-	-							-	-	-	-
J22 (RX: COAX)	-		-	-							-	-	-	-
J23 (TX: COAX)	-		-	-							-	-	-	-

Table 64. Use / Not use of the jumper pins, cables, connectors and the destinations of the connections

**(b). In case of using BNC cable and BNC-RCA conversion connector and RCA connector**

Jumper pins Cables Connectors	OPT	COAX	Use	Not use	Destinations of the connections					
					PORT6 (RX: OPT)	PORT7 (TX: OPT)	J22 (RX: COAX)	J23 (TX: COAX)	External optical connector	External BNC connector
JP94 (RX)	-		/	/	/					
JP95 (TX)	-	-								
Optical cable										
BNC cable										
BNC-RCA conversion connector										
PORT6 (RX: OPT)			-		-	-	-	-	-	-
PORT7 (TX: OPT)			-		-	-	-	-	-	-
J22 (RX: COAX)				-	-	-	-	-	-	-
J23 (TX: COAX)			-		-	-	-	-	-	-

Table 65. Use / Not use of the jumper pins, cables, connectors and the destinations of the connections

**(c). Other common setting**

Jumper pins	Master	Slave	Short	Open	CODEC	DIR	DIT	BNC	10-pin	Open
JP65 (AK4614-Master/Slave)		-	/		/					
JP1 (XTI/MCKI)										
JP63 (AK4614-XTI/MCKI)	/	/	/	/	-		-	-	-	-
JP64 (AK4614-BICK)					-	-	-	-	-	
JP66 (AK4614-LRCK)					-	-	-	-	-	
JP67 (DIR-AK4114-XTI)					-	-	-	-	-	
JP70 (DIR-AK4114-BICK)					-	-	-	-	-	
JP71 (DIR-AK4114-LRCK)					-	-	-	-	-	
JP73 (DIT-AK4114-XTI)					-	-	-	-	-	
JP75 (DIT-AK4114-BICK)					-	-	-	-	-	
JP76 (DIT-AK4114-LRCK)					-	-	-	-	-	

Table 66. The settings of the jumper pins (modes and clocks)

JP207 (SDTO) should be open.

Jumper pins		SDTO1	SDTO2	SDTO3	Open	DIR	10-pin	GND	Open
JP207 (SDTO)	Always	-	-	-	(Note1)				
JP201 (SDTI1)	SDTI1 input						-	-	-
	No input					-	-	-	
JP202 (SDTI2)	SDTI2 input						-	-	-
	No input					-	-	-	
JP203 (SDTI3)	SDTI3 input						-	-	-
	No input					-	-	-	
JP204 (SDTI4)	SDTI4 input						-	-	-
	No input					-	-	-	
JP205 (SDTI5)	SDTI5 input						-	-	-
	No input					-	-	-	
JP206 (SDTI6)	SDTI6 input						-	-	-
	No input					-	-	-	

Table 67. The settings of the jumper pins (digital inputs / digital outputs)

(Note1) Connect DAUX side of DIT: AK4114 (U26) to GND by the clips.

Switch names	Pin No.	Signal names	Values	Functions
SW2 (MODE-AK4614)	4	M/S	H	Master Mode
SW4 (DIR-AK4114-MODE)	1	DIF2	H	Slave Mode, 24bit I2S Compatible
	2	DIF1	H	
	3	DIF0	H	
	4	CM1	L	PLL Mode
	5	CM0	L	
SW6 (DIT-AK4114-MODE)	1	DIF2	H	Slave Mode, 24bit I2S Compatible
	2	DIF1	H	
	3	DIF0	H	
	4	CM1	L	X'tal Mode
	5	CM0	H	

Table 68. The settings of the DIP switches

Switch on the power supply units, and do the settings of the toggle switches as follows.

Switch names	Values	Functions
SW3 (PDN-AK4614)	L→H	Power down→Power up
SW5 (PDN-DIR-AK4114)	L→H	Power down→Power up
SW7 (PDN-DIT-AK4114)	L	Power down

Table 69. The settings of the toggle switches

Starts up the control software, click “Write default” button, write the default value.

The combinations of settings of jumper pins and digital inputs / analog outputs paths are as follows.

Combinations	Settings of the jumper pins	Digital inputs / analog outputs paths
1	JP201 (SDTI1)=DIR JP202 (SDTI2)=DIR JP203 (SDTI3)= DIR JP204 (SDTI4)= DIR JP205 (SDTI5)= DIR JP206 (SDTI6)= DIR	SDTI1-Lch→LOUT1 SDTI1-Rch→ROUT1 SDTI2-Lch→LOUT2 SDTI2-Rch→ROUT2 SDTI3-Lch→LOUT3 SDTI3-Rch→ROUT3 SDTI4-Lch→LOUT4 SDTI4-Rch→ROUT4 SDTI5-Lch→LOUT5 SDTI5-Rch→ROUT5 SDTI6-Lch→LOUT6 SDTI6-Rch→ROUT6

Table 70. The combinations of settings of the jumper pins and digital inputs / analog outputs paths

**(5)-2. Slave mode**

Devices (Parts)	Use	Not use	Removed	Clock sources			Modes	
				External clock	X'tal	PLL	Master	Slave
AK4614 (U1)		-	-		-	-	-	
DIR: AK4114 (U23)		-	-	-	-			-
DIT: AK4114 (U26)	-		-	-	-	-	-	-
X'tal: X1	-			/			/	
X'tal: X2	-							
X'tal: X3	-							

Table 71. Use / Not use of the devices (parts) and the modes of using

**(a). In case of using optical cable and optical connector**

Jumper pins Cables Connectors	OPT	COAX	Use	Not use	Destinations of the connections					
					PORT6 (RX: OPT)	PORT7 (TX: OPT)	J22 (RX: COAX)	J23 (TX: COAX)	External optical connector	External BNC connector
JP94 (RX)		-	/		/					
JP95 (TX)	-	-								
Optical cable	/			-	/					
BNC cable			-							
BNC-RCA conversion connector			-							
PORT6 (RX: OPT)				-						
PORT7 (TX: OPT)	-				-	-	-	-	-	-
J22 (RX: COAX)	-				-	-	-	-	-	-
J23 (TX: COAX)	-				-	-	-	-	-	-

Table 72. Use / Not use of the jumper pins, cables, connectors and the destinations of the connections

**(b). In case of using BNC cable and BNC-RCA conversion connector and RCA connector**

Jumper pins Cables Connectors	OPT	COAX	Use	Not use	Destinations of the connections					
					PORT6 (RX: OPT)	PORT7 (TX: OPT)	J22 (RX: COAX)	J23 (TX: COAX)	External optical connector	External BNC connector
JP94 (RX)	-		/	/	/					
JP95 (TX)	-	-								
Optical cable										
BNC cable										
BNC-RCA conversion connector										
PORT6 (RX: OPT)			-	-	-	-	-	-	-	
PORT7 (TX: OPT)			-	-	-	-	-	-	-	
J22 (RX: COAX)				-	-	-	-	-	-	
J23 (TX: COAX)			-	-	-	-	-	-	-	

Table 73. Use / Not use of the jumper pins, cables, connectors and the destinations of the connections

**(c). Other common setting**

Jumper pins	Master	Slave	Short	Open	CODEC	DIR	DIT	BNC	10-pin	Open						
JP65 (AK4614-Master/Slave)	-		/	/	/											
JP1 (XTI/MCKI)											-					
JP63 (AK4614-XTI/MCKI)											-	-	-	-	-	-
JP64 (AK4614-BICK)											-	-	-	-	-	-
JP66 (AK4614-LRCK)											-	-	-	-	-	-
JP67 (DIR-AK4114-XTI)											-	-	-	-	-	-
JP70 (DIR-AK4114-BICK)											-	-	-	-	-	-
JP71 (DIR-AK4114-LRCK)											-	-	-	-	-	-
JP73 (DIT-AK4114-XTI)											-	-	-	-	-	-
JP75 (DIT-AK4114-BICK)											-	-	-	-	-	-
JP76 (DIT-AK4114-LRCK)											-	-	-	-	-	-

Table 74. The settings of the jumper pins (modes and clocks)

JP207 (SDTO) should be open.

Jumper pins		SDTO1	SDTO2	SDTO3	Open	DIR	10-pin	GND	Open
JP207 (SDTO)	Always	-	-	-	(Note1)				
JP201 (SDTI1)	SDTI1 input						-	-	-
	No input					-	-	-	
JP202 (SDTI2)	SDTI2 input						-	-	-
	No input					-	-	-	
JP203 (SDTI3)	SDTI3 input						-	-	-
	No input					-	-	-	
JP204 (SDTI4)	SDTI4 input						-	-	-
	No input					-	-	-	
JP205 (SDTI5)	SDTI5 input						-	-	-
	No input					-	-	-	
JP206 (SDTI6)	SDTI6 input						-	-	-
	No input					-	-	-	

Table 75. The settings of the jumper pins (digital inputs / digital outputs)

(Note1) Connect DAUX side of DIT: AK4114 (U26) to GND by the clips.

Switch names	Pin No.	Signal names	Values	Functions
SW2 (MODE-AK4614)	4	M/S	L	Slave Mode
SW4 (DIR-AK4114-MODE)	1	DIF2	H	Master Mode, 24bit I2S Compatible
	2	DIF1	L	
	3	DIF0	H	
	4	CM1	L	PLL Mode
	5	CM0	L	
SW6 (DIT-AK4114-MODE)	1	DIF2	H	Slave Mode, 24bit I2S Compatible
	2	DIF1	H	
	3	DIF0	H	
	4	CM1	L	X'tal Mode
	5	CM0	H	

Table 76. The settings of the DIP switches

Switch on the power supply units, and do the settings of the toggle switches as follows.

Switch names	Values	Functions
SW3 (PDN-AK4614)	L→H	Power down→Power up
SW5 (PDN-DIR-AK4114)	L→H	Power down→Power up
SW7 (PDN-DIT-AK4114)	L	Power down

Table 77. The settings of the toggle switches

Starts up the control software, click “Write default” button, write the default value.

The combinations of the settings of the jumper pins and digital inputs / analog outputs paths are as follows.

Combinations	Settings of the jumper pins	Digital inputs / analog outputs paths
1	JP201 (SDTI1)=DIR JP202 (SDTI2)=DIR JP203 (SDTI3)= DIR JP204 (SDTI4)= DIR JP205 (SDTI5)= DIR JP206 (SDTI6)= DIR	SDTI1-Lch→LOUT1 SDTI1-Rch→ROUT1 SDTI2-Lch→LOUT2 SDTI2-Rch→ROUT2 SDTI3-Lch→LOUT3 SDTI3-Rch→ROUT3 SDTI4-Lch→LOUT4 SDTI4-Rch→ROUT4 SDTI5-Lch→LOUT5 SDTI5-Rch→ROUT5 SDTI6-Lch→LOUT6 SDTI6-Rch→ROUT6

Table 78. The combinations of the settings of the jumper pins and digital inputs / analog outputs paths

**(6) The evaluation mode of ADC (Analog → Digital) with the external clocks**
**(6)-1. Slave mode**

Devices (Parts)	Use	Not use	Removed	Clock sources			Modes	
				External clock	X'tal	PLL	Master	Slave
AK4614 (U1)		-	-		-	-	-	
DIR: AK4114 (U23)	-		-	-	-	-	-	-
DIT: AK4114 (U26)	-		-	-	-	-	-	-
X'tal: X1	-			/			/	
X'tal: X2	-							
X'tal: X3	-							

Table 79. Use / Not use of the devices (parts) and the modes of using

**(a). In case of using 10-line flat cable and 10-pin connector for the external clock  
(Using 10-line flat cable and 10-pin connector for the data)**

Cables Connectors	Use	Not use	Destinations of the connections								
			PORT1 (MCLK BICK LRCK)	PORT2 (SDTI1 SDTI2 SDTI3)	PORT3 (SDTI4 SDTI5 SDTI6)	PORT4 (SDTO1 SDTO2 SDTO3)	J19 (EXT-MCLK)	J20 (EXT-BICK)	J21 (EXT-LRCK)	External 10-pin connector	External BNC connector
10-line flat cable		-	/								
BNC cable	-										
BNC-RCA conversion connector	-										
PORT1 (MCLK BICK LRCK)		-	-	-	-	-	-	-	-	-	-
PORT2 (SDTI1 SDTI2 SDTI3)		-	-	-	-	-	-	-	-	-	-
PORT3 (SDTI4 SDTI5 SDTI6)		-	-	-	-	-	-	-	-	-	-
PORT4 (SDTO1 SDTO2 SDTO3)		-	-	-	-	-	-	-	-	-	-
J19 (EXT-MCLK)	-		-	-	-	-	-	-	-	-	-
J20 (EXT-BICK)	-		-	-	-	-	-	-	-	-	-
J21 (EXT-LRCK)	-		-	-	-	-	-	-	-	-	-

Table 80. Use / Not use of the cables, connectors and the destinations of the connections

Jumper pins	Master	Slave	Short	Open	CODEC	DIR	DIT	BNC	10-pin	Open
JP65 (AK4614-Master/Slave)	-									
JP1 (XTI/MCKI)				-						
JP63 (AK4614-XTI/MCKI)					-	-	-	-		-
JP64 (AK4614-BICK)					-	-	-	-		-
JP66 (AK4614-LRCK)					-	-	-	-		-
JP67 (DIR-AK4114-XTI)					-	-	-	-	-	
JP70 (DIR-AK4114-BICK)					-	-	-	-	-	
JP71 (DIR-AK4114-LRCK)					-	-	-	-	-	
JP73 (DIT-AK4114-XTI)					-	-	-	-	-	
JP75 (DIT-AK4114-BICK)					-	-	-	-	-	
JP76 (DIT-AK4114-LRCK)					-	-	-	-	-	

Table 81. The settings of the jumper pins (modes and clocks)

(i) In case of not using UPD. / In case of using UPD and not inverting BICK.

Jumper pins	THR	INV	Open
JP69 (BICK-THR / INV)		-	-

Table 82. The settings of the jumper pins (clocks)

(ii) In case of using UPD and inverting BICK.

Jumper pins	THR	INV	Open
JP69 (BICK-THR / INV)	-		-

Table 83. The settings of the jumper pins (clocks)

**(b). In case of using BNC cable and BNC-RCA conversion connector and RCA connector for the external clock  
(Using 10-line flat cable and 10-pin connector for the data)**

Cables Connectors	Use	Not use	Destinations of the connections								
			PORT1 (MCLK BICK LRCK)	PORT2 (SDTI1 SDTI2 SDTI3)	PORT3 (SDTI4 SDTI5 SDTI6)	PORT4 (SDTO1 SDTO2 SDTO3)	J19 (EXT- MCLK)	J20 (EXT- BICK)	J21 (EXT- LRCK)	External 10-pin connector	External BNC connector
10-line flat cable		-	/								
BNC cable		-									
BNC-RCA conversion connector		-									
PORT1 (MCLK BICK LRCK)	-		-	-	-	-	-	-	-	-	-
PORT2 (SDTI1 SDTI2 SDTI3)			-	-	-	-	-	-	-	-	-
PORT3 (SDTI4 SDTI5 SDTI6)			-	-	-	-	-	-	-	-	-
PORT4 (SDTO1 SDTO2 SDTO3)			-	-	-	-	-	-	-	-	-
J19 (EXT- MCLK)		-	-	-	-	-	-	-	-	-	-
J20 (EXT- BICK)		-	-	-	-	-	-	-	-	-	-
J21 (EXT- LRCK)		-	-	-	-	-	-	-	-	-	-

Table 84. Use / Not use of the cables, connectors and the destinations of the connections

Jumper pins	Master	Slave	Short	Open	CODEC	DIR	DIT	BNC	10-pin	Open
JP65 (AK4614-Master/Slave)	-		/							
JP1 (XTI/MCKI)										
JP63 (AK4614-XTI/MCKI)			-	-	-	-	-	-	-	-
JP64 (AK4614-BICK)			-	-	-	-	-	-	-	-
JP66 (AK4614-LRCK)			-	-	-	-	-	-	-	-
JP67 (DIR-AK4114-XTI)			-	-	-	-	-	-	-	-
JP70 (DIR-AK4114-BICK)			-	-	-	-	-	-	-	-
JP71 (DIR-AK4114-LRCK)			-	-	-	-	-	-	-	-
JP73 (DIT-AK4114-XTI)			-	-	-	-	-	-	-	-
JP75 (DIT-AK4114-BICK)			-	-	-	-	-	-	-	-
JP76 (DIT-AK4114-LRCK)			-	-	-	-	-	-	-	-

Table 85. The settings of the jumper pins (modes and clocks)

(i) In case of not using UPD.

Jumper pins	THR	INV	Open
JP69 (BICK-THR / INV)		-	-

Table 86. The settings of the jumper pins (clocks)

### (c). Other common setting

JP207 (SDTO) should be open.

Jumper pins		SDTO1	SDTO2	SDTO3	Open	DIR	10-pin	GND	Open				
JP207 (SDTO)	Always	-	-	-	(Note1)								
JP201 (SDTI1)	Always									-	-		-
JP202 (SDTI2)	Always									-		-	
JP203 (SDTI3)	Always									-		-	
JP204 (SDTI4)	Always									-		-	
JP205 (SDTI5)	Always									-		-	
JP206 (SDTI6)	Always									-		-	

Table 87. The settings of the jumper pins (digital inputs / digital outputs)

(Note1) Connect DAUX side of DIT: AK4114 (U26) to GND by the clips.

Switch names	Pin No.	Signal names	Values	Functions
SW2 (MODE-AK4614)	4	M/S	L	Slave Mode
SW4 (DIR-AK4114-MODE)	1	DIF2	H	Slave Mode, 24bit I2S Compatible
	2	DIF1	H	
	3	DIF0	H	
	4	CM1	L	X'tal Mode
	5	CM0	H	
SW6 (DIT-AK4114-MODE)	1	DIF2	H	Slave Mode, 24bit I2S Compatible
	2	DIF1	H	
	3	DIF0	H	
	4	CM1	L	X'tal Mode
	5	CM0	H	

Table 88. The settings of the DIP switches

Switch on the power supply units, and do the settings of toggle switches as follows.

Switch names	Values	Functions
SW3 (PDN-AK4614)	L→H	Power down→Power up
SW5 (PDN-DIR-AK4114)	L	Power down
SW7 (PDN-DIT-AK4114)	L	Power down

Table 89. The settings of the toggle switches

Starts up the control software, click “Write default” button, write the default value.

Analog inputs / digital outputs paths are as follows.

Analog inputs / digital outputs paths
LIN1→SDTO1-Lch
RIN1→SDTO1-Rch
LIN2→SDTO2-Lch
RIN2→SDTO2-Rch
LIN3→SDTO3-Lch
RIN3→SDTO3-Rch

Table 90. Analog inputs / digital outputs paths

**(7) The evaluation mode of DAC (Digital → Analog) with the external clocks**
**(7)-1. Slave mode**

Devices (Parts)	Use	Not use	Removed	Clock sources			Modes	
				External clock	X'tal	PLL	Master	Slave
AK4614 (U1)		-	-		-	-	-	
DIR: AK4114 (U23)	-		-	-	-	-	-	-
DIT: AK4114 (U26)	-		-	-	-	-	-	-
X'tal: X1	-			/			/	
X'tal: X2	-							
X'tal: X3	-							

Table 91. Use / Not use of the devices (parts) and the modes of using

**(a). In case of using 10-line flat cable and 10-pin connector for the external clock  
(Using 10-line flat cable and 10-pin connector for the data)**

Cables Connectors	Use	Not use	Destinations of the connections								
			PORT1 (MCLK BICK LRCK)	PORT2 (SDTI1 SDTI2 SDTI3)	PORT3 (SDTI4 SDTI5 SDTI6)	PORT4 (SDTO1 SDTO2 SDTO3)	J19 (EXT-MCLK)	J20 (EXT-BICK)	J21 (EXT-LRCK)	External 10-pin connector	External BNC connector
10-line flat cable		-	/								
BNC cable	-										
BNC-RCA conversion connector	-										
PORT1 (MCLK BICK LRCK)		-	-	-	-	-	-	-	-	-	-
PORT2 (SDTI1 SDTI2 SDTI3)		-	-	-	-	-	-	-	-	-	-
PORT3 (SDTI4 SDTI5 SDTI6)		-	-	-	-	-	-	-	-	-	-
PORT4 (SDTO1 SDTO2 SDTO3)		-	-	-	-	-	-	-	-	-	-
J19 (EXT-MCLK)	-		-	-	-	-	-	-	-	-	-
J20 (EXT-BICK)	-		-	-	-	-	-	-	-	-	-
J21 (EXT-LRCK)	-		-	-	-	-	-	-	-	-	-

Table 92. Use / Not use of the cables, connectors and the destinations of the connections

Jumper pins	Master	Slave	Short	Open	CODEC	DIR	DIT	BNC	10-pin	Open
JP65 (AK4614-Master/Slave)	-									
JP1 (XTI/MCKI)				-						
JP63 (AK4614-XTI/MCKI)					-	-	-	-		-
JP64 (AK4614-BICK)					-	-	-	-		-
JP66 (AK4614-LRCK)					-	-	-	-		-
JP67 (DIR-AK4114-XTI)					-	-	-	-	-	
JP70 (DIR-AK4114-BICK)					-	-	-	-	-	
JP71 (DIR-AK4114-LRCK)					-	-	-	-	-	
JP73 (DIT-AK4114-XTI)					-	-	-	-	-	
JP75 (DIT-AK4114-BICK)					-	-	-	-	-	
JP76 (DIT-AK4114-LRCK)					-	-	-	-	-	

Table 93. The settings of the jumper pins (modes and clocks)

(i) In case of not using UPD. / In case of using UPD and not inverting BICK.

Jumper pins	THR	INV	Open
JP69 (BICK-THR / INV)		-	-

Table 94. The settings of the jumper pins (clocks)

(ii) In case of using UPD and inverting BICK.

Jumper pins	THR	INV	Open
JP69 (BICK-THR / INV)	-		-

Table 95. The settings of the jumper pins (clocks)

**(b). In case of using BNC cable and BNC-RCA conversion connector and RCA connector for the external clock  
(Using 10-line flat cable and 10-pin connector for the data)**

Cables Connectors	Use	Not use	Destinations of the connections								
			PORT1 (MCLK BICK LRCK)	PORT2 (SDTI1 SDTI2 SDTI3)	PORT3 (SDTI4 SDTI5 SDTI6)	PORT4 (SDTO1 SDTO2 SDTO3)	J19 (EXT-MCLK)	J20 (EXT-BICK)	J21 (EXT-LRCK)	External 10-pin connector	External BNC connector
10-line flat cable		-	/								
BNC cable		-									
BNC-RCA conversion connector		-									
PORT1 (MCLK BICK LRCK)	-		-	-	-	-	-	-	-	-	-
PORT2 (SDTI1 SDTI2 SDTI3)			-	-	-	-	-	-	-	-	-
PORT3 (SDTI4 SDTI5 SDTI6)			-	-	-	-	-	-	-	-	-
PORT4 (SDTO1 SDTO2 SDTO3)			-	-	-	-	-	-	-	-	-
J19 (EXT-MCLK)		-	-	-	-	-	-	-	-	-	-
J20 (EXT-BICK)		-	-	-	-	-	-	-	-	-	-
J21 (EXT-LRCK)		-	-	-	-	-	-	-	-	-	-

Table 96. Use / Not use of the cables, connectors and the destinations of the connections

Jumper pins	Master	Slave	Short	Open	CODEC	DIR	DIT	BNC	10-pin	Open
JP65 (AK4614-Master/Slave)	-		/							
JP1 (XTI/MCKI)										
JP63 (AK4614-XTI/MCKI)										
JP64 (AK4614-BICK)										
JP66 (AK4614-LRCK)										
JP67 (DIR-AK4114-XTI)										
JP70 (DIR-AK4114-BICK)										
JP71 (DIR-AK4114-LRCK)										
JP73 (DIT-AK4114-XTI)										
JP75 (DIT-AK4114-BICK)										
JP76 (DIT-AK4114-LRCK)										

Table 97. The settings of the jumper pins (modes and clocks)

(i) In case of not using UPD.

Jumper pins	THR	INV	Open
JP69 (BICK-THR / INV)		-	-

Table 98. The settings of the jumper pins (clocks)

### (c). Other common setting

JP207 (SDTO) should be open.

Jumper pins		SDTO1	SDTO2	SDTO3	Open	DIR	10-pin	GND	Open				
JP207 (SDTO)	Always	-	-	-	(Note1)	/							
JP201 (SDTI1)	SDTI1 input									-		-	-
	No input									-	-		-
JP202 (SDTI2)	SDTI2 input									-		-	-
	No input									-	-		-
JP203 (SDTI3)	SDTI3 input									-		-	-
	No input									-	-		-
JP204 (SDTI4)	SDTI4 input									-		-	-
	No input									-	-		-
JP205 (SDTI5)	SDTI5 input									-		-	-
	No input									-	-		-
JP206 (SDTI6)	SDTI6 input									-		-	-
	No input									-	-		-

Table 99. The settings of jumper pins (digital inputs / digital outputs)

(Note1) Connect DAUX side of DIT: AK4114 (U26) to GND by the clips.

Switch names	Pin No.	Signal names	Values	Functions
SW2 (MODE-AK4614)	4	M/S	L	Slave Mode
SW4 (DIR-AK4114-MODE)	1	DIF2	H	Slave Mode, 24bit I2S Compatible
	2	DIF1	H	
	3	DIF0	H	
	4	CM1	L	X'tal Mode
	5	CM0	H	
SW6 (DIT-AK4114-MODE)	1	DIF2	H	Slave Mode, 24bit I2S Compatible
	2	DIF1	H	
	3	DIF0	H	
	4	CM1	L	X'tal Mode
	5	CM0	H	

Table 100. The settings of the DIP switches

Switch on the power supply units, and do the settings of toggle switches as follows.

Switch names	Values	Functions
SW3 (PDN-AK4614)	L→H	Power down→Power up
SW5 (PDN-DIR-AK4114)	L	Power down
SW7 (PDN-DIT-AK4114)	L	Power down

Table 101. The settings of the toggle switches

Starts up the control software, click “Write default” button, write the default value.

The combinations of the settings of the jumper pins and digital inputs / analog outputs paths are as follows.

Combinations	Settings of the jumper pins	Digital inputs / analog outputs paths
1	JP201 (SDTI1)= 10-pin JP202 (SDTI2)= 10-pin JP203 (SDTI3)= 10-pin JP204 (SDTI4)= 10-pin JP205 (SDTI5)= 10-pin JP206 (SDTI6)= 10-pin	SDTI1-Lch→LOUT1 SDTI1-Rch→ROUT1 SDTI2-Lch→LOUT2 SDTI2-Rch→ROUT2 SDTI3-Lch→LOUT3 SDTI3-Rch→ROUT3 SDTI4-Lch→LOUT4 SDTI4-Rch→ROUT4 SDTI5-Lch→LOUT5 SDTI5-Rch→ROUT5 SDTI6-Lch→LOUT6 SDTI6-Rch→ROUT6

Table 102. The combinations of the settings of the jumper pins and digital inputs / analog outputs paths

## Control Software Manual

### ■ Set-up of evaluation board and control software

1. Set up the AKD4614-A according to previous term.
2. Connect IBM-AT compatible PC with AKD4614-A by 10-line type flat cable (packed with AKD4614-A). Take care of the direction of 10pin header. (Please install the driver in the CD-ROM when this control software is used on Windows 2000/XP. Please refer "Installation Manual of Control Software Driver by AKM device control software". In case of Windows95/98/ME, this installation is not needed. This control software does not operate on Windows NT.)
3. Insert the CD-ROM labeled "AKD4614-A Evaluation Kit" into the CD-ROM drive.
4. Access the CD-ROM drive, double-click the icon of "akd4614-a.exe" and set up the control program.
5. Then evaluate according to the follows.

### ■ Operation flow

Keep the following flow.

1. Set up the control program according to explanation above.
2. Click "Write default" button.
3. Then set up the dialog and input the data and evaluate the AK4614.

### ■ Explanation of each buttons

- |                     |   |
|---------------------|---|
| 1. [Port Reset]:    | Set up the USB interface board (AKDUSBIF-A).  |
| 2. [Write Default]: | Initialize the register of AK4614.  |
| 3. [All Write]:     | Write all registers that are currently displayed.   |
| 4. [All Read]:      | Read all registers of the AK4614.   |
| 5. [Function1]:     | Dialog to write data by keyboard operation.   |
| 6. [Function2]:     | Dialog to write data by keyboard operation.   |
| 7. [Function3]:     | The sequence of register setting can be set and executed.   |
| 8. [Function4]:     | The sequence that is created on [Function3] can be assigned to buttons and executed.                            |
| 9. [Function5]:     | The register setting that is created by [SAVE] function on main window can be assigned to buttons and executed. |
| 10. [Save]:         | Save the current register setting.  |
| 11. [Open]:         | Write the saved values to all register.   |
| 12. [Write]:        | Dialog to write data by mouse operation.  |
| 13. [Read]:         | Dialog to read data by mouse operation.   |

### ■ Indication of data

Input data is indicated on the register map. Red letter indicates "H" or "1" and blue one indicates "L" or "0". Blank is the part that is not defined in the datasheet.

## ■ Explanation of each dialog

### 1. [Write Dialog]: Dialog to write data by mouse operation

There are dialogs corresponding to each register.

Click the [Write] button corresponding to each register to set up the dialog. If you check the check box, data becomes “H” or “1”. If not, “L” or “0”.

If you want to write the input data to AK4614, click [OK] button. If not, click [Cancel] button.

### 2. [Function1 Dialog]: Dialog to write data by keyboard operation

Address Box: Input registers address in 2 figures of hexadecimal.

Data Box: Input registers data in 2 figures of hexadecimal.

If you want to write the input data to AK4614, click [OK] button. If not, click [Cancel] button.

### 3. [Function2 Dialog]: Dialog to evaluate Volume Control

Address Box: Input registers address in 2 figures of hexadecimal.

Start Data Box: Input starts data in 2 figures of hexadecimal.

End Data Box: Input end data in 2 figures of hexadecimal.

Interval Box: Data is written to AK4614 by this interval.

Step Box: Data changes by this step.

Mode Select Box:

If you check this check box, data reaches end data, and returns to start data.

[Example] Start Data = 00, End Data = 09

Data flow: 00 01 02 03 04 05 06 07 08 09 09 08 07 06 05 04 03 02 01 00

If you do not check this check box, data reaches end data, but does not return to start data.

[Example] Start Data = 00, End Data = 09

Data flow: 00 01 02 03 04 05 06 07 08 09

If you want to write the input data to AK4614, click [OK] button. If not, click [Cancel] button.

## 4. [Save] and [Open]

### 4-1. [Save]

Save the current register setting data. The extension of file name is “.akr”.

<Operation flow>

(1) Click [Save] Button.

(2) Set the file name and push [Save] Button. The extension of file name is “.akr”.

### 4-2. [Open]

The register setting data saved by [Save] is written to AK4614. The file type is the same as [Save].

<Operation flow>

(1) Click [Open] Button.

(2) Select the file (\*.akr) and Click [Open] Button.

### 5. [Function3 Dialog]

The sequence of register setting can be set and executed.

(1) Click [F3] Button.

(2) Set the control sequence.

Set the address, Data and Interval time. Set “-1” to the address of the step where the sequence should be paused.

(3) Click [Start] button. Then this sequence is executed.

The sequence is paused at the step of Interval="-1". Click [START] button, the sequence restarts from the paused step.

This sequence can be saved and opened by [Save] and [Open] button on the Function3 window. The extension of file name is “aks”.

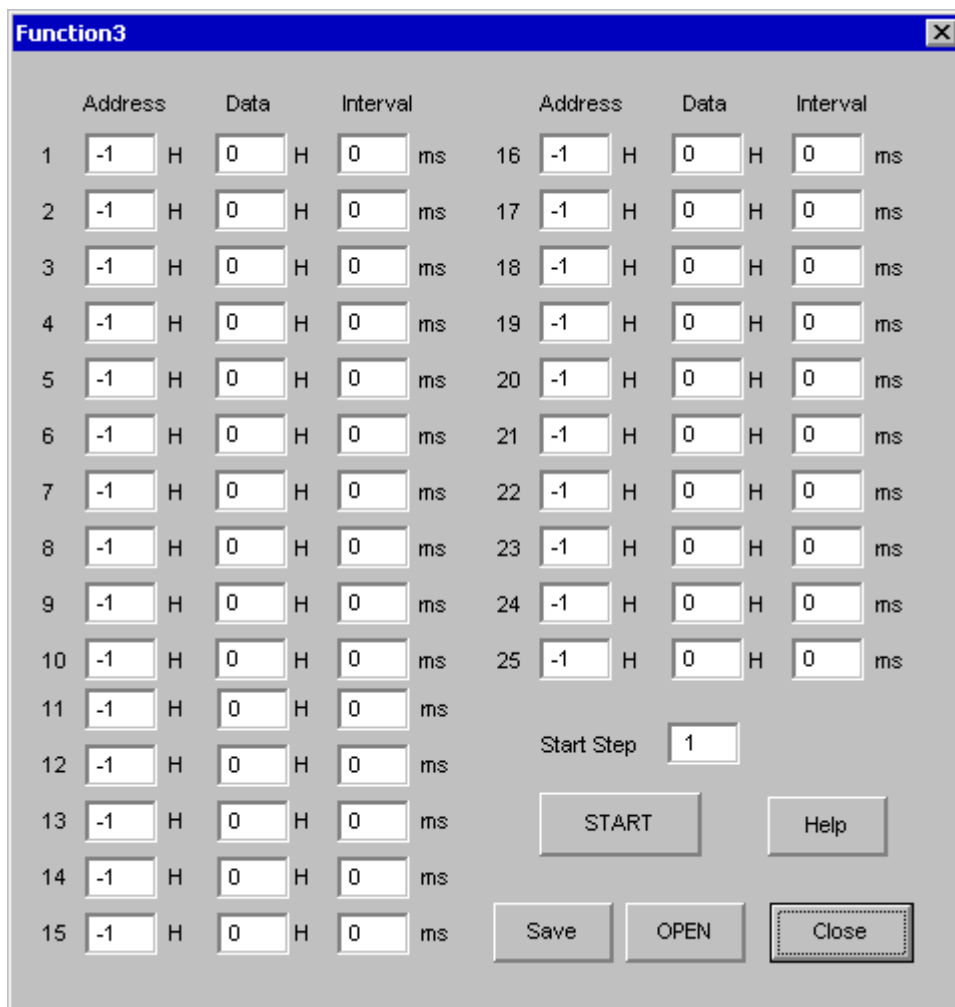

Figure 3. Window of [F3]

### 6. [Function4 Dialog]

The sequence that is created on [Function3] can be assigned to buttons and executed. When [F4] button is clicked, the window as shown in Figure 4. is opened.

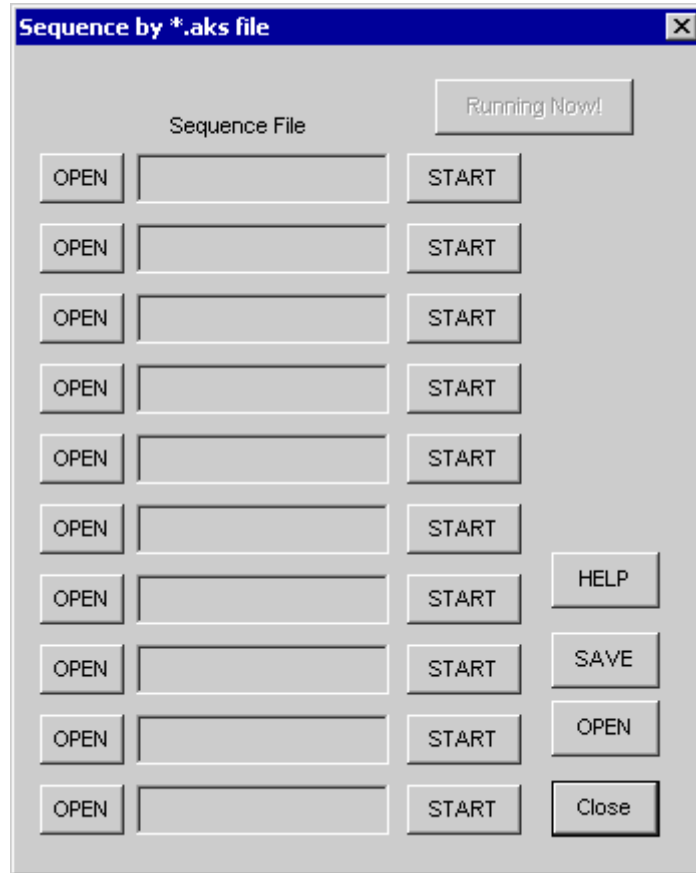

Figure 4. [F4] window

**6-1. [OPEN] buttons on left side and [START] buttons**

(1) Click [OPEN] button and select the sequence file (\*.aks).

The sequence file name is displayed as shown in Figure 5.

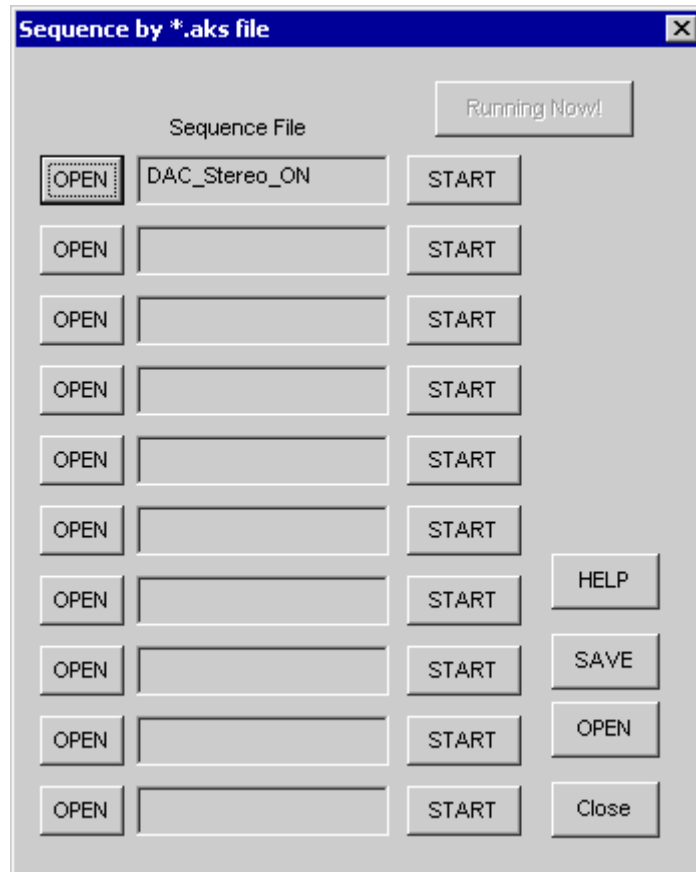

Figure 5. [F4] window (2)

(2) Click [START] button, then the sequence is executed.

**6-2. [SAVE] and [OPEN] buttons on right side**

[SAVE]: The sequence file names can assign be saved. The file name is \*.ak4.

[OPEN]: The sequence file names assign that are saved in \*.ak4 are loaded.

**6-3. Note**

(1) This function doesn't support the pause function of sequence function.

(2) All files need to be in same folder used by [SAVE] and [OPEN] function on right side.

(3) When the sequence is changed in [Function3], the file should be loaded again in order to reflect the change.

## 7. [Function5 Dialog]

The register setting that is created by [SAVE] function on main window can be assigned to buttons and executed. When [F5] button is clicked, the following window as shown in Figure 6.opens.

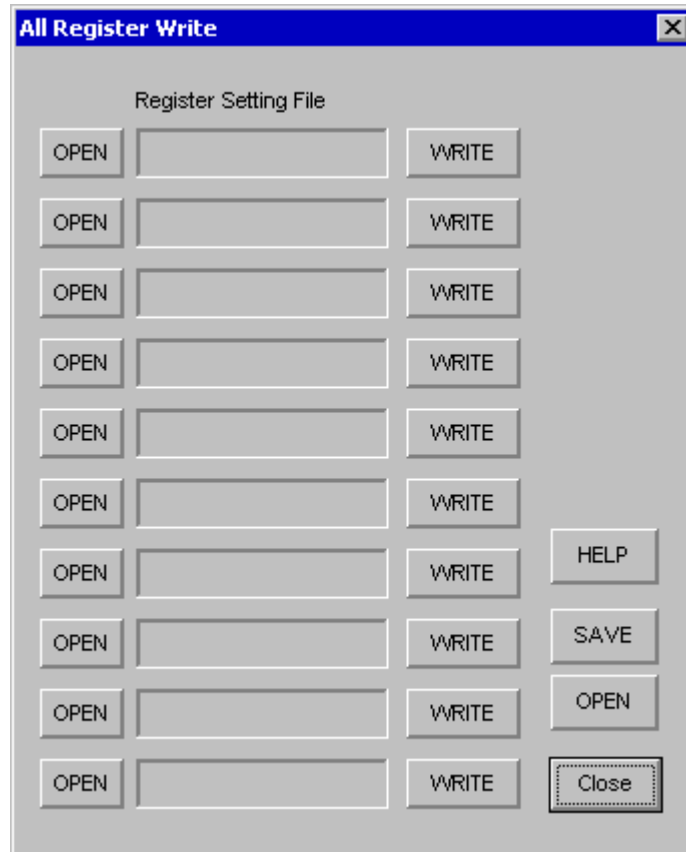

Figure 6. [F5] window

### 7-1. [OPEN] buttons on left side and [WRITE] button

(1) Click [OPEN] button and select the register setting file (\*.akr).

The register setting file name is displayed as shown in Figure 7.

(2) Click [WRITE] button, then the register setting is executed.

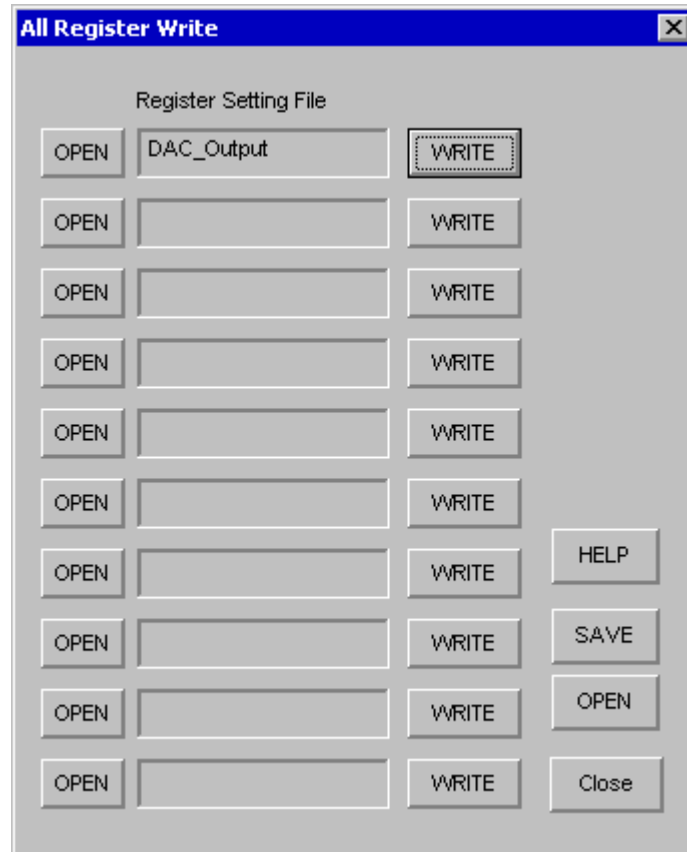

Figure 7. [F5] windows (2)

### 7-2. [SAVE] and [OPEN] buttons on right side

[SAVE]: The register setting file names assign can be saved. The file name is \*.ak5.

[OPEN]: The register setting file names assign that are saved in \*.ak5 are loaded.

### 7-3. Note

- (1) All files need to be in same folder used by [SAVE] and [OPEN] function on right side.
- (2) When the register setting is changed by [Save] Button in main window, the file should be loaded again in order to reflect the change

<b>Revision History</b>
-------------------------

Date (yy/mm/dd)	Manual Revision	Board Revision	Reason	Page	Contents
07/11/08	KM090300	0	First Edition		

IMPORTANT NOTICE

- These products and their specifications are subject to change without notice.  
When you consider any use or application of these products, please make inquiries the sales office of Asahi Kasei EMD Corporation (AKEMD) or authorized distributors as to current status of the products.
- AKEMD assumes no liability for infringement of any patent, intellectual property, or other rights in the application or use of any information contained herein.
- Any export of these products, or devices or systems containing them, may require an export license or other official approval under the law and regulations of the country of export pertaining to customs and tariffs, currency exchange, or strategic materials.
- AKEMD products are neither intended nor authorized for use as critical components<sup>Note1)</sup> in any safety, life support, or other hazard related device or system<sup>Note2)</sup>, and AKEMD assumes no responsibility for such use, except for the use approved with the express written consent by Representative Director of AKEMD. As used here:
  - Note1) A critical component is one whose failure to function or perform may reasonably be expected to result, whether directly or indirectly, in the loss of the safety or effectiveness of the device or system containing it, and which must therefore meet very high standards of performance and reliability.
  - Note2) A hazard related device or system is one designed or intended for life support or maintenance of safety or for applications in medicine, aerospace, nuclear energy, or other fields, in which its failure to function or perform may reasonably be expected to result in loss of life or in significant injury or damage to person or property.
- It is the responsibility of the buyer or distributor of AKEMD products, who distributes, disposes of, or otherwise places the product with a third party, to notify such third party in advance of the above content and conditions, and the buyer or distributor agrees to assume any and all responsibility and liability for and hold AKEMD harmless from any and all claims arising from the use of said product in the absence of such notification.

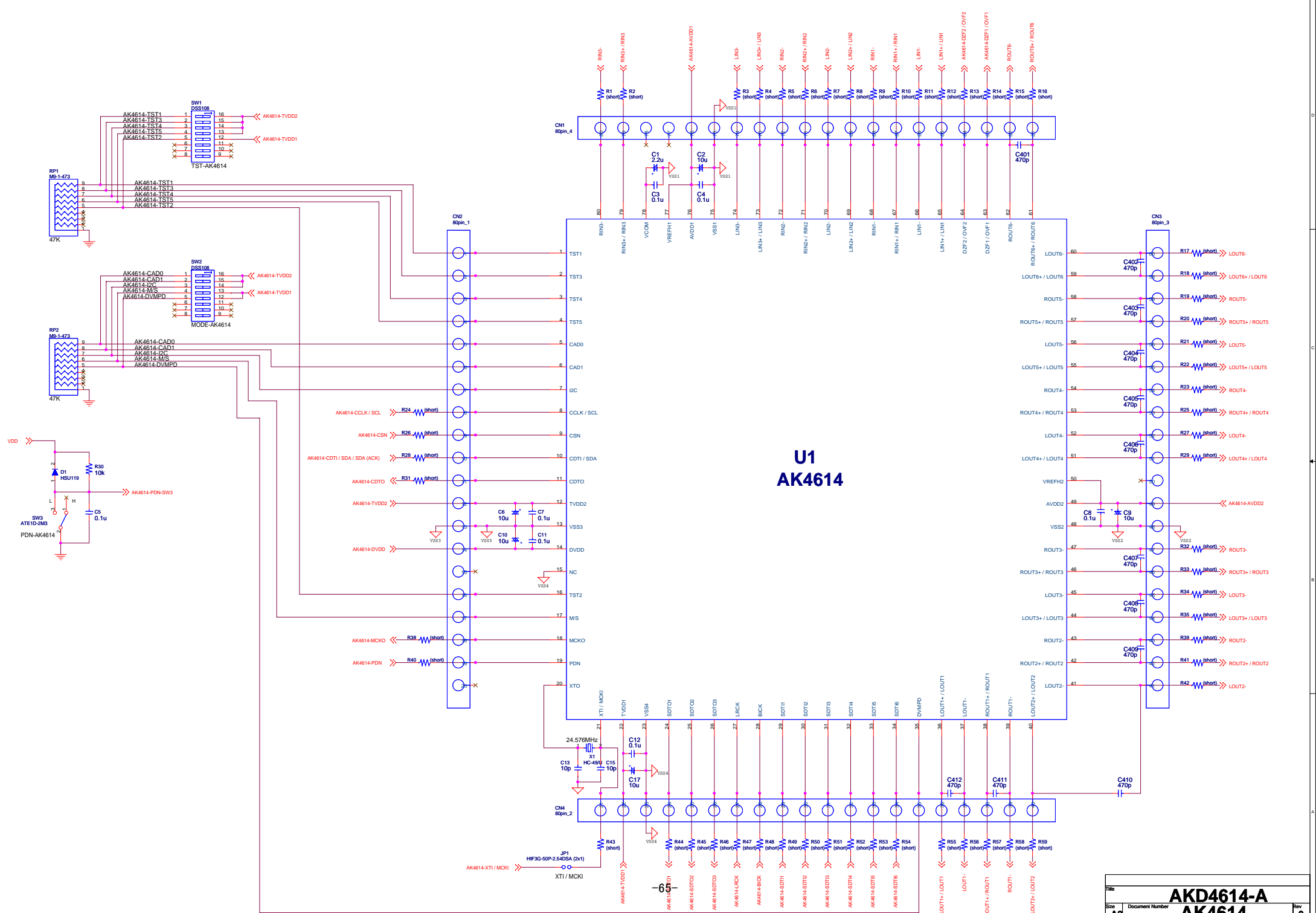

Title		<b>AKD4614-A</b>	
Size	Document Number	<b>AK4614</b>	
<b>A2</b>			Rev <b>0</b>
Date: Thursday, September 20, 2007		Sheet	1 of 12





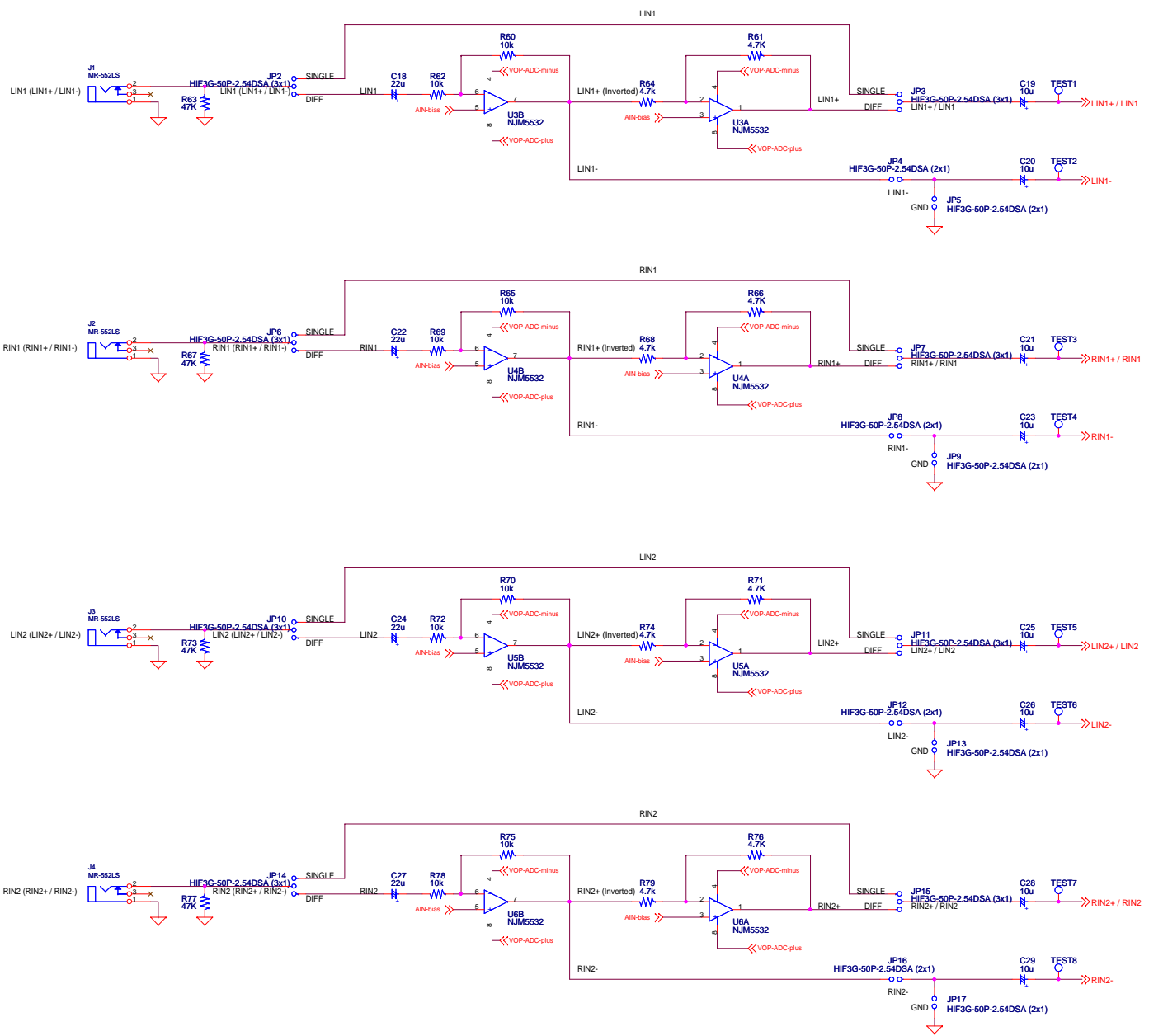

Title			<b>AKD4614-A</b>		
Size	Document Number	ANALOG INPUT RCA-1 / RCA-2			Rev
A2					0
Date:	Monday, August 20, 2007	Sheet	2	of	12

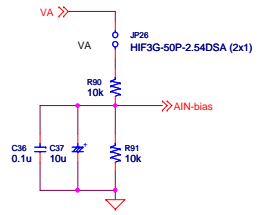
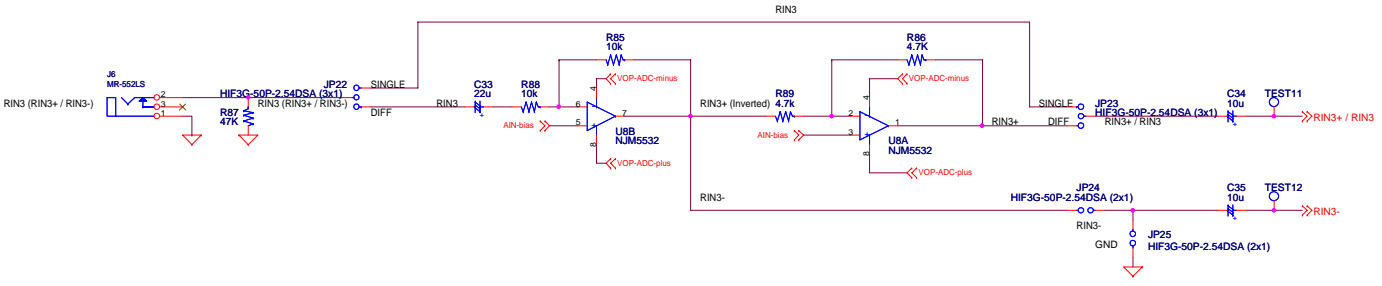
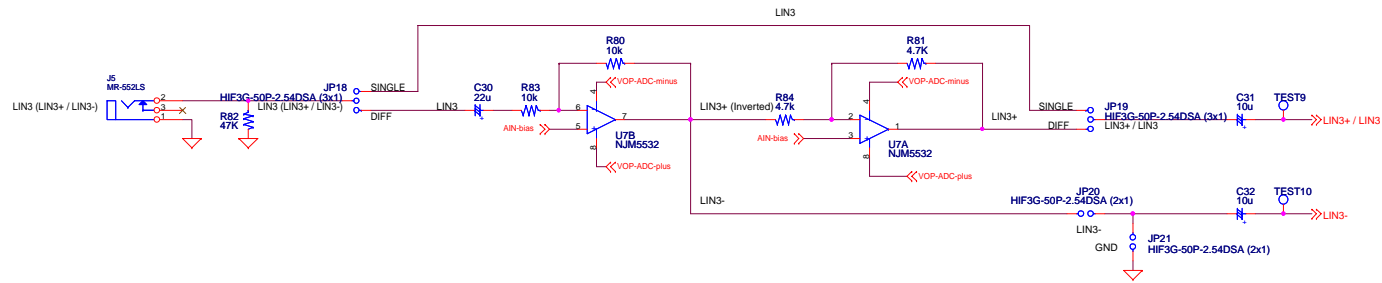

Title			<b>AKD4614-A</b>		
Size	Document Number	Rev			0
A2	<b>ANALOG INPUT RCA-3</b>				
Date:	Monday, August 20, 2007	Sheet	3	of	12

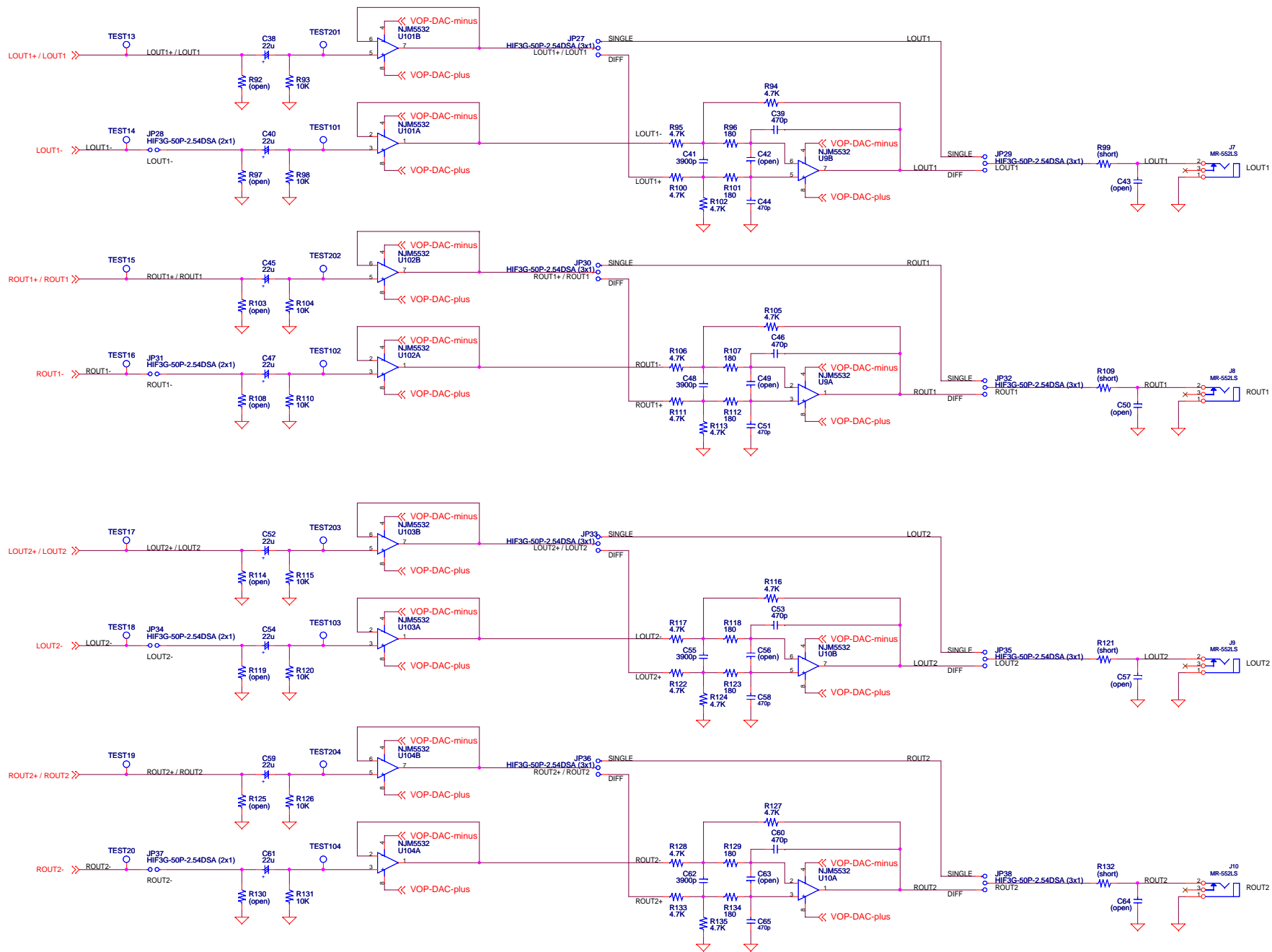

Title			<b>AKD4614-A</b>
Size	Document Number	ANALOG OUTPUT RCA-1 / RCA-2	
A2			Rev 0
Date:	Wednesday, August 29, 2007	Sheet	4 of 12

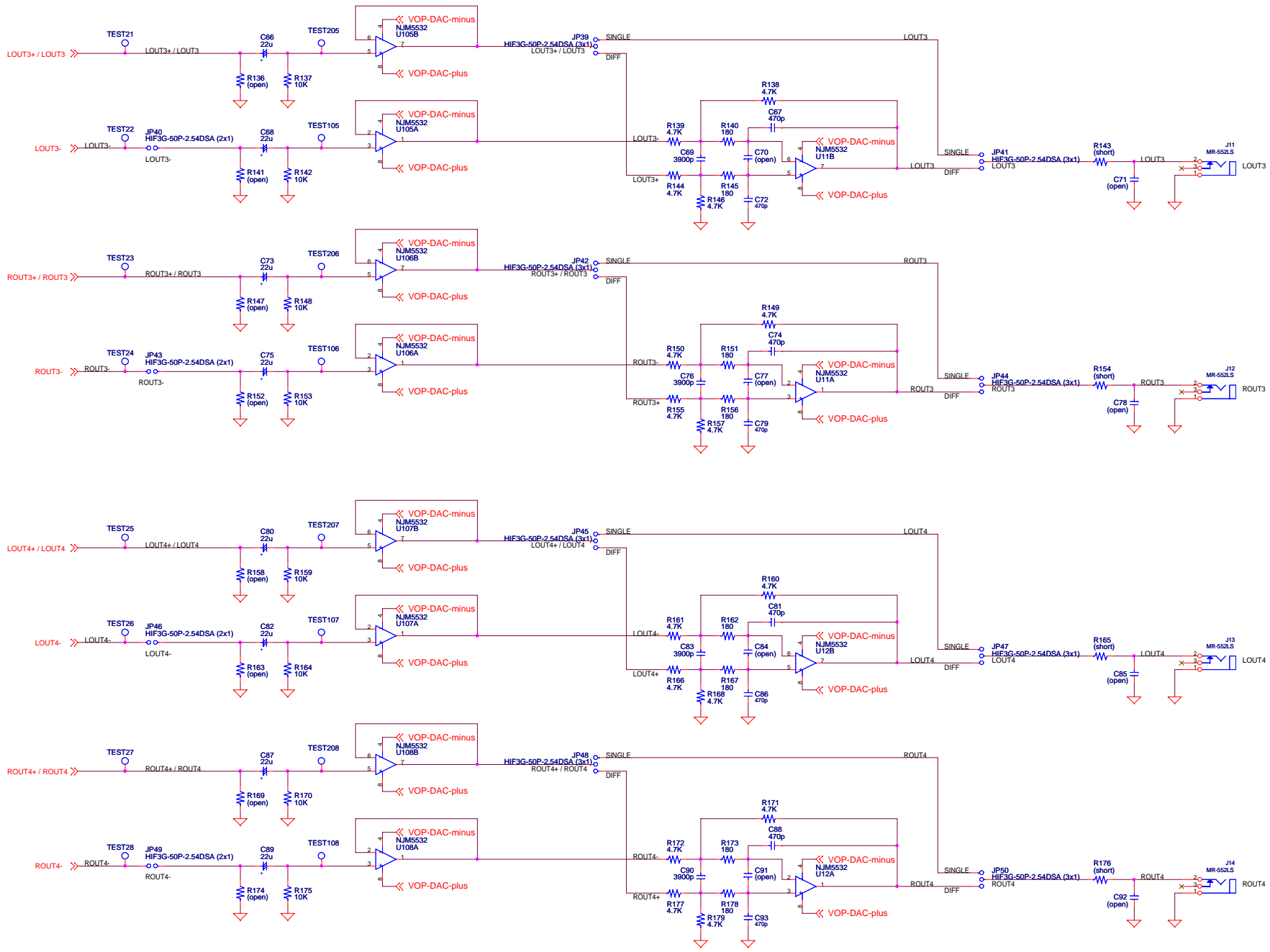

Title		
<b>AKD4614-A</b>		
Size	Document Number	Rev
A2	<b>ANALOG OUTPUT RCA-3 / RCA-4</b>	0
Date:	Wednesday, August 29, 2007	Sheet 5 of 12

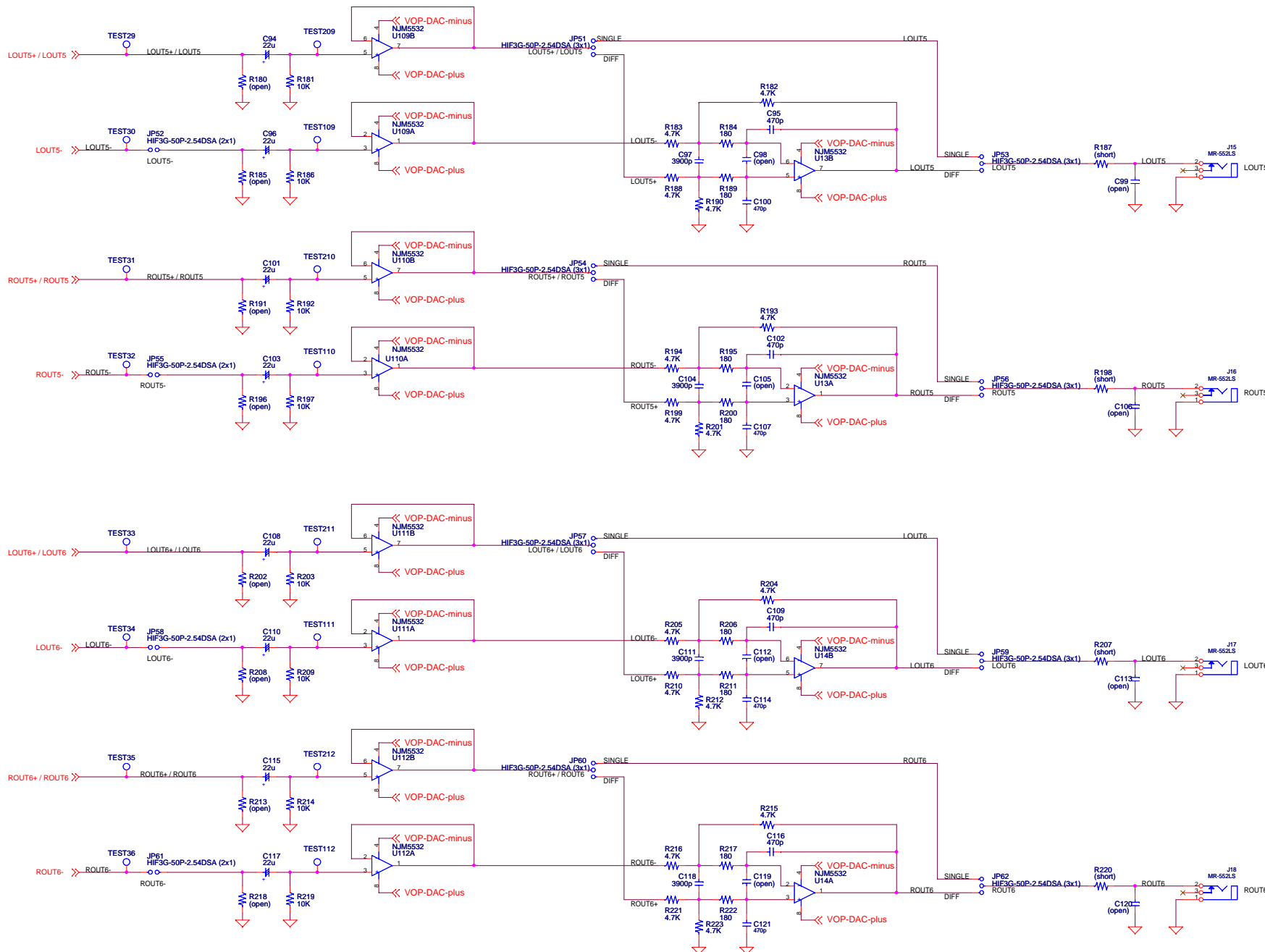

Title			<b>AKD4614-A</b>		
Size	Document Number	ANALOG OUTPUT RCA-5 / RCA-6			Rev
A2					0
Date:	Wednesday, August 29, 2007	Sheet	6	of	12

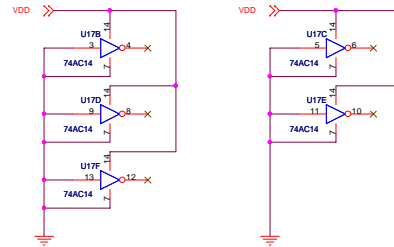
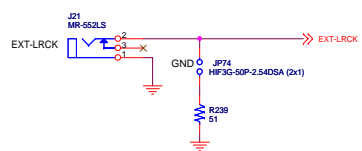
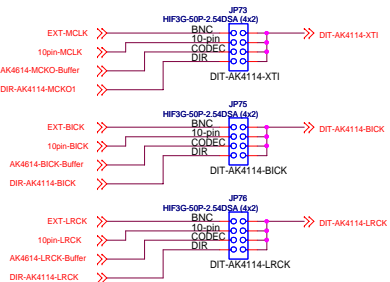
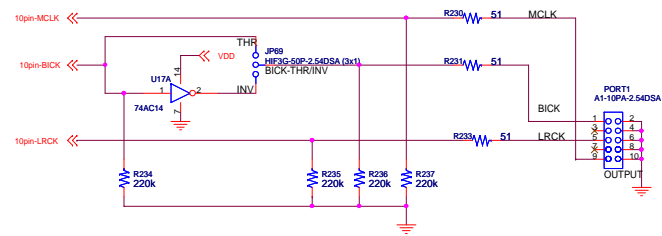
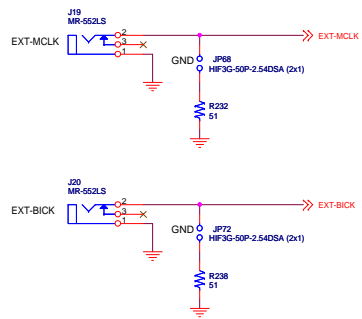
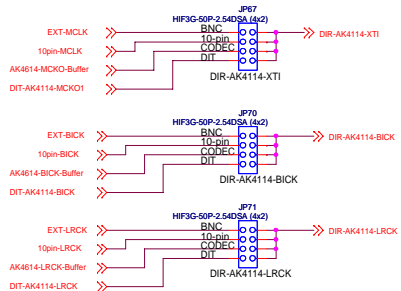
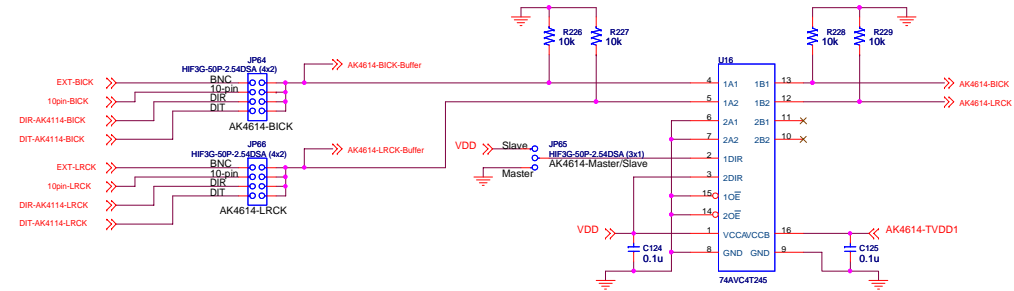
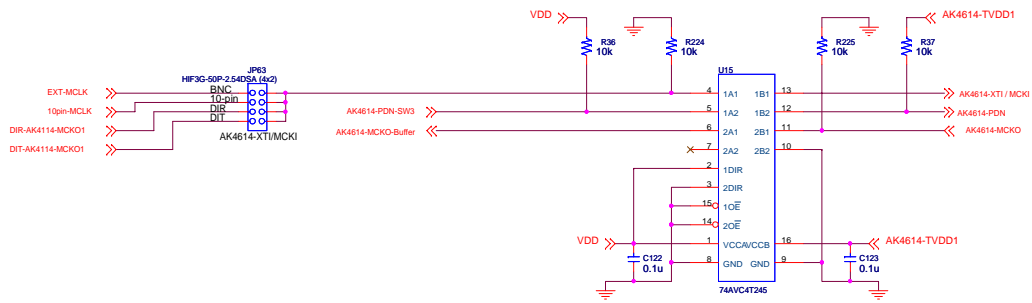

Title				<b>AKD4614-A</b>	
Size	Document Number	Part Number		Rev	0
A2	<b>DIGITAL INPUT OUTPUT1</b>				
Date:	Thursday, August 16, 2007	Sheet	7	of	12

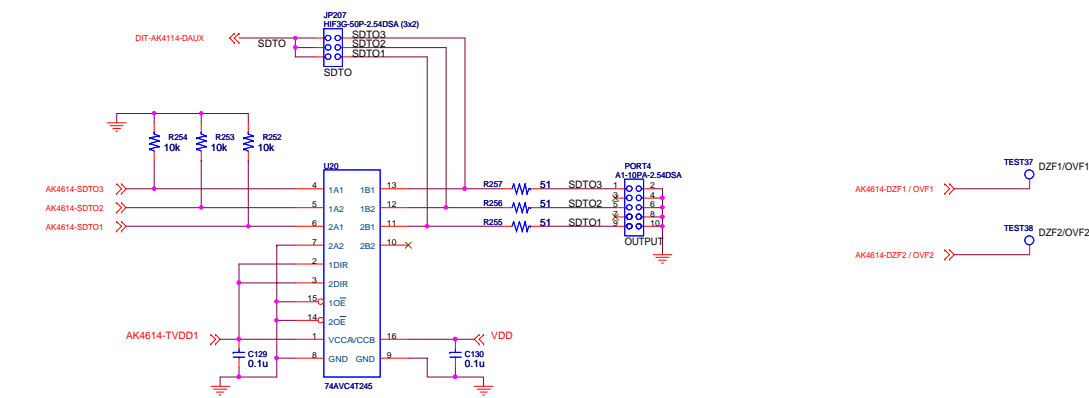
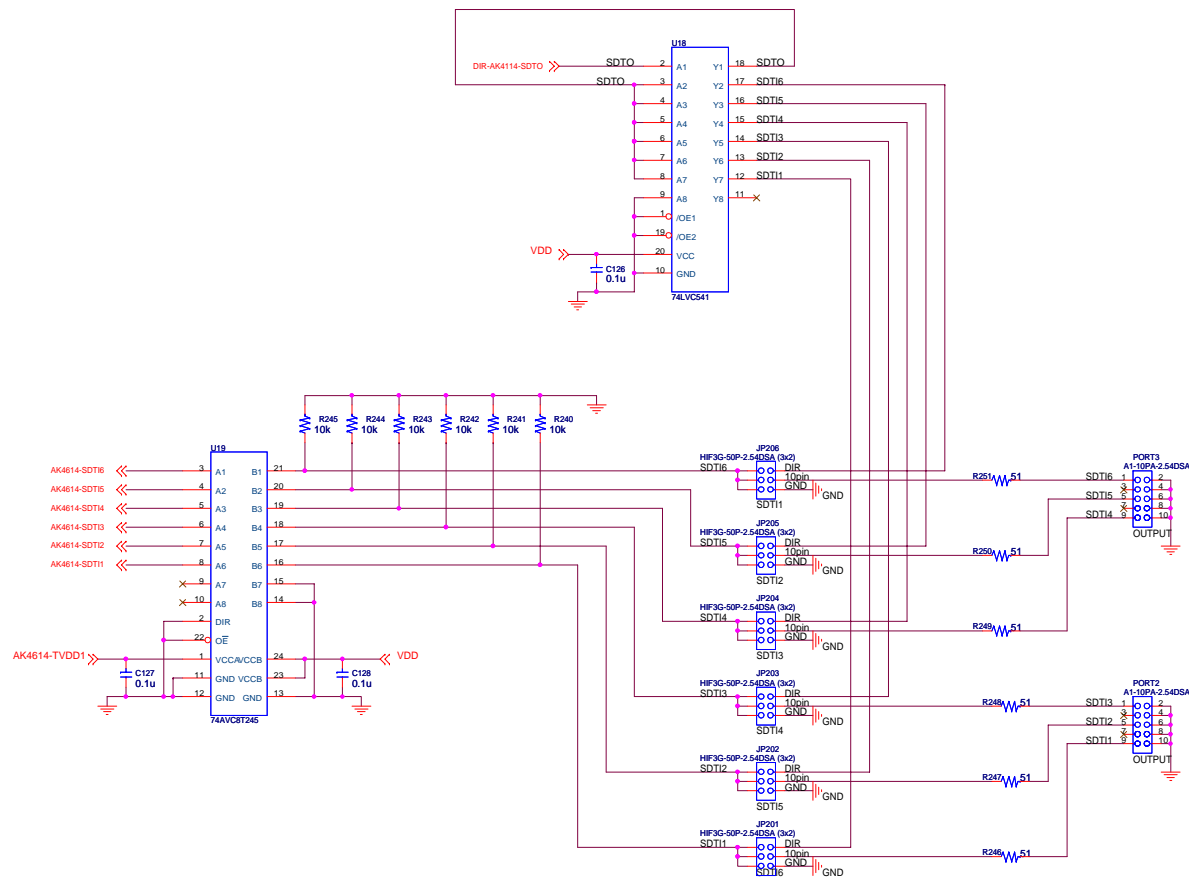

Title			<b>AKD4614-A</b>		
Size	Document Number				Rev
A2	<b>DIGITAL INPUT OUTPUT2</b>			0	
Date:	Wednesday, August 29, 2007	Sheet	8	of	12

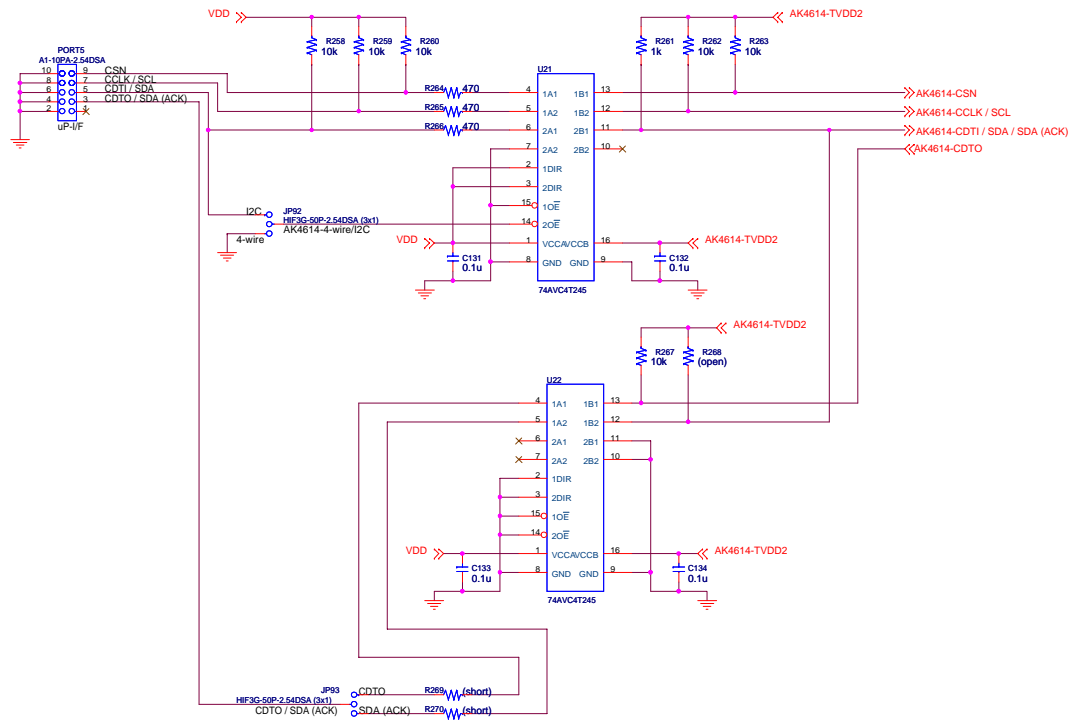

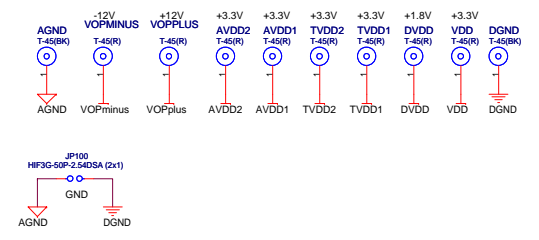
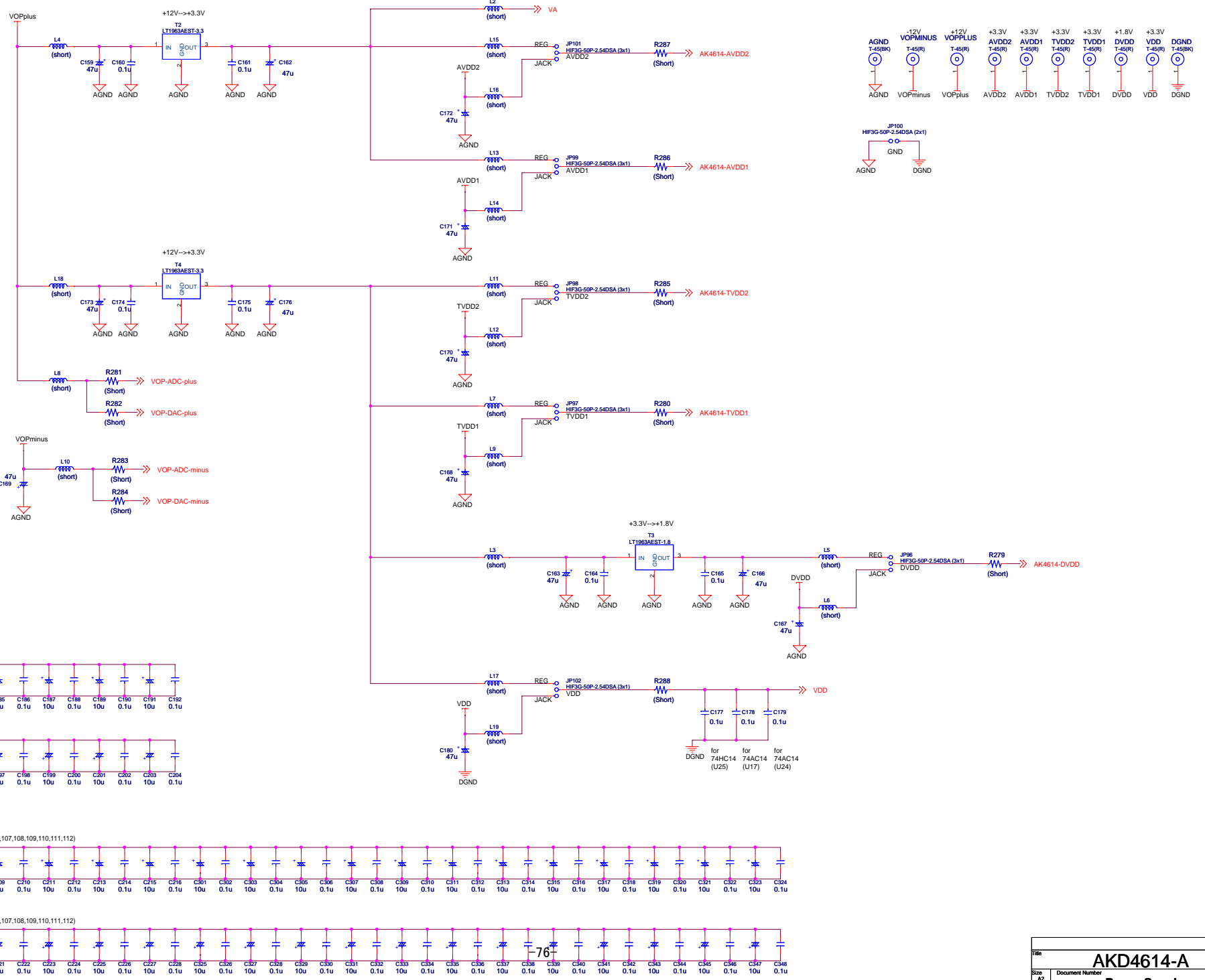

Title			AKD4614-A		
Size	Document Number				Rev
A2					0
Date			Power Supply		
Wednesday, August 29, 2007			Sheet 12 of 12		

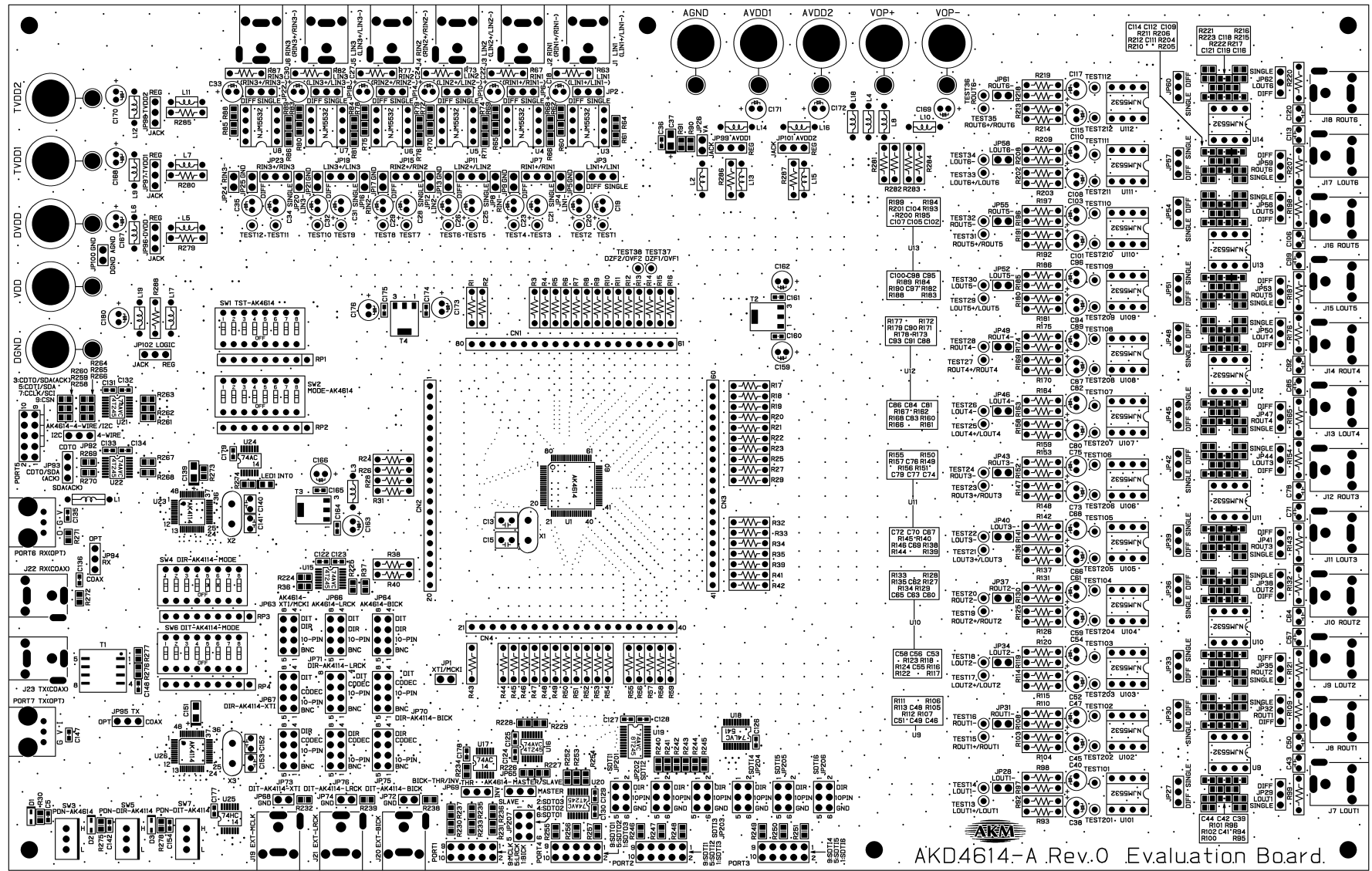

AKM  
AKD4614-A Rev.0 Evaluation Board.

L1 S/R SILK



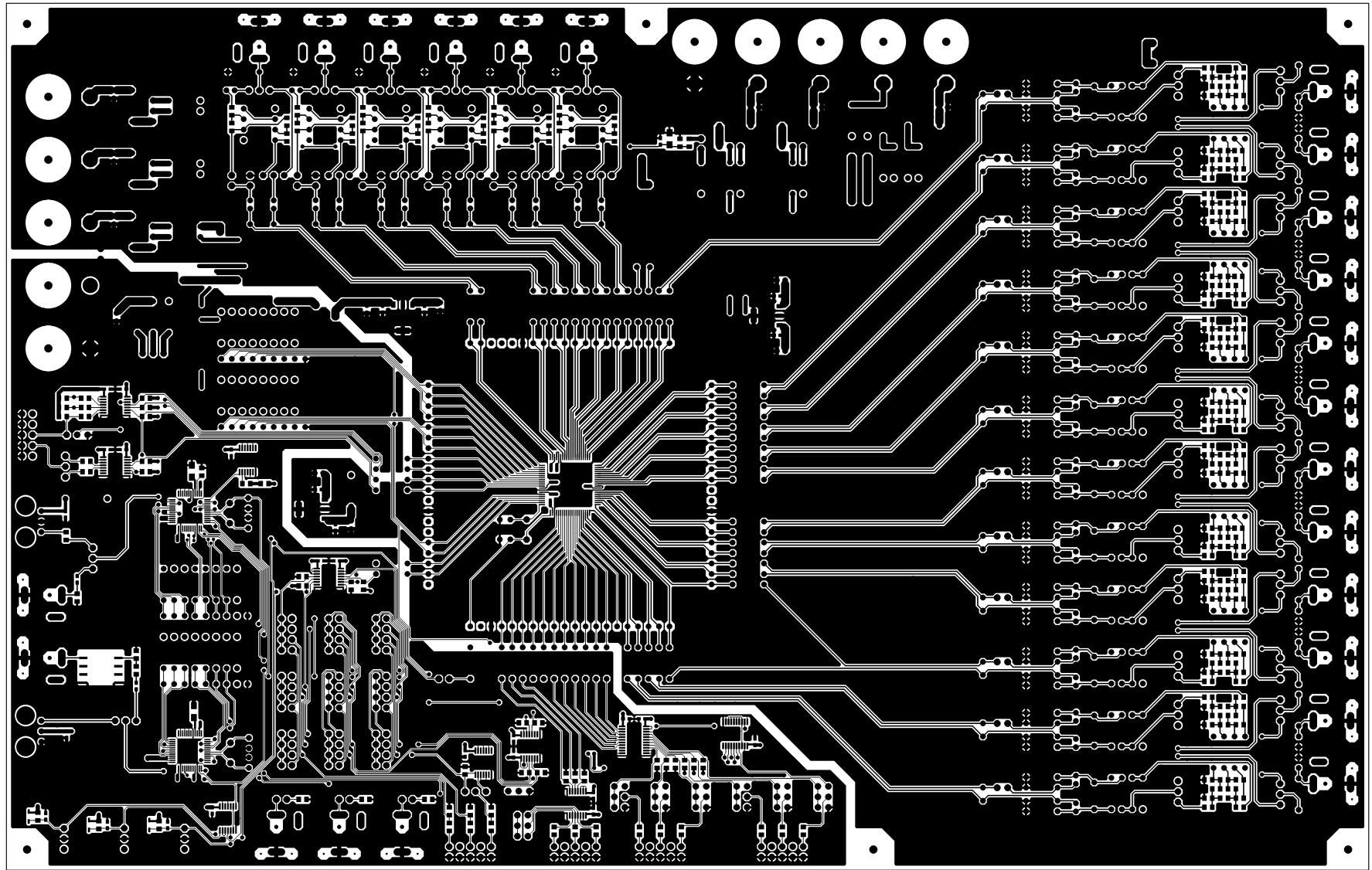

L1 PATTERN

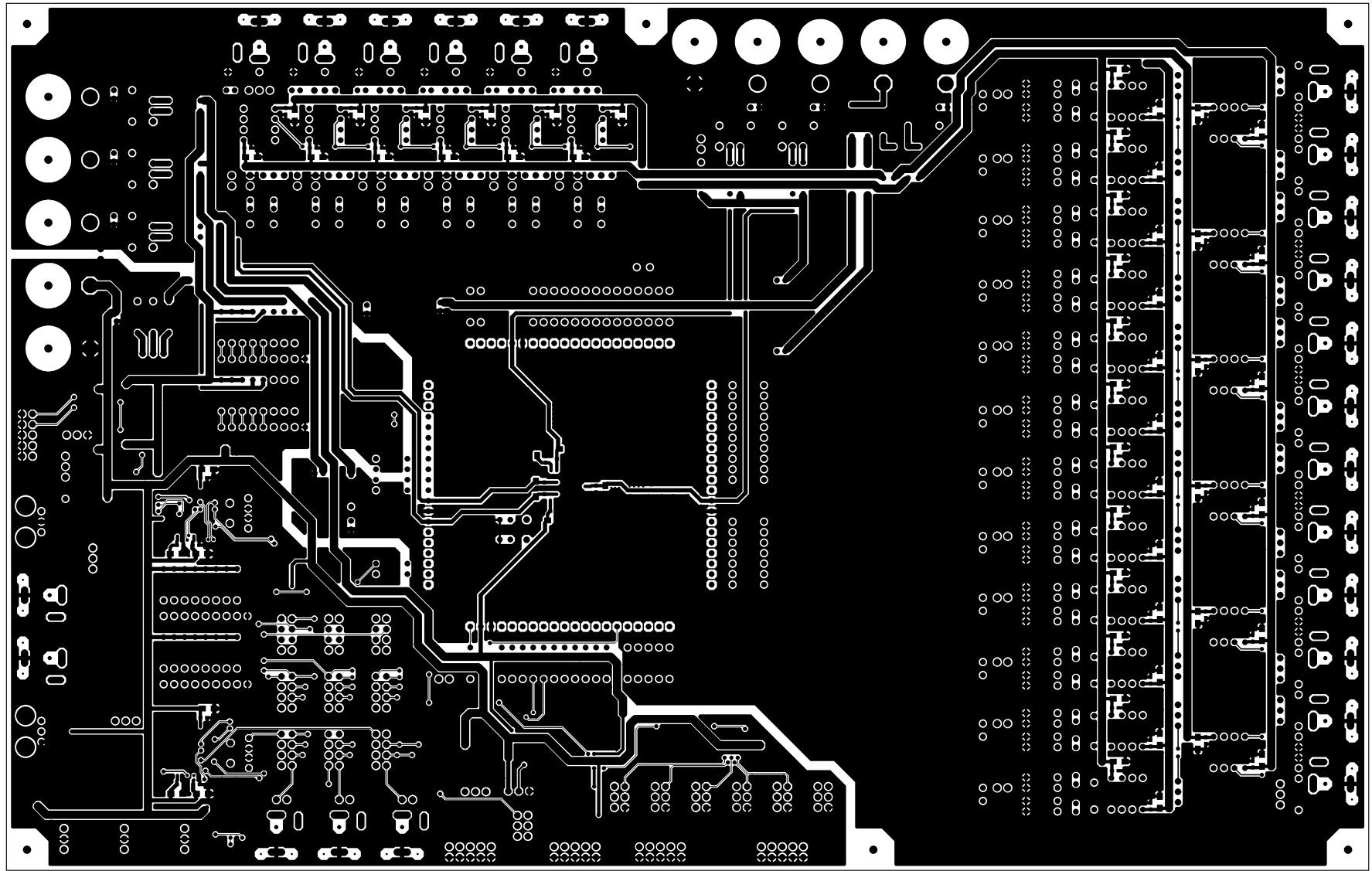

L2 PATTERN