

**AK4706****2ch 24bit DAC with AV Switch & HD/SD Video Filter****GENERAL DESCRIPTION**

The AK4706 offers the ideal features for digital set-top-box systems. Using AKM's multi-bit architecture for its modulator, the AK4706 delivers a wide dynamic range while preserving linearity for improved THD+N performance. The AK4706 integrates a combination of SCF and CTF filters, removing the need for high cost external filters and increasing performance for systems with excessive clock jitter. The AK4706 also including the audio switches, volumes, video switches, HD/SD video filters, etc. designed primarily for digital set-top-box systems with SCART routing. The AK4706 is offered in a space saving 64-pin LQFP package.

**FEATURES****□DAC**

Sampling Rates Ranging from 8kHz to 50kHz  
 64dB High Attenuation 8x FIR Digital Filter  
 2nd Order Analog LPF  
 On Chip Buffer with Single-Ended Output  
 Digital De-Emphasis for 32k, 44.1k and 48kHz Sampling  
 I/F Format: 24bit MSB Justified, I<sup>2</sup>S, 18/16bit LSB Justified  
 Master Clock: 256fs, 384fs  
 High Tolerance to Clock Jitter

**□Analog Switches****Audio Section**

THD+N: -86dB (@2Vrms)  
 Dynamic Range: 96dB (@2Vrms)  
 Stereo Analog Volume with Pop-noise Free Circuit: +6dB to -60dB & Mute  
 Analog Inputs

Two Stereo Inputs (TV&VCR SCART)  
 One Stereo Input (Changeover to Internal DAC)

**Analog Outputs**

Two Stereo Outputs (TV, VCR SCART)  
 One Mono Output (Modulator)

Pop Noise Free Circuit for Power On/Off

**Video Section****Integrated LPF**

SD: -40dB@27MHz  
 HD: -40dB@74.25MHz or 54MHz or 27MHz selectable

**75ohm Driver**

6dB Gain for Outputs

**Adjustable Gain**

Four CVBS/Y Inputs (ENCx2, TV, VCR), Three CVBS/Y Outputs (RF, TV, VCR)

Three R/C Inputs (ENCx2, VCR), Two R/C outputs (TV, VCR)

Three G and B Inputs (ENC, VCR, HD), Two G and B Outputs (TV, HD)

Bi-Directional Control for VCR-Red/Chroma

YPbPr Option (to 6MHz)

**VCR Input Monitor**

Loop-Through Mode for Standby

Auto-Startup Mode for Power Saving

SCART Pin#16(Fast Blanking), Pin#8(Slow Blanking) Control

S1/S2 DC Control

- AK4702/05 Software Compatible
- Power Supply  
5V+/-5% and 12V+/-5%
- Low Power Dissipation / Low Power Standby Mode
- Package  
Small 64pin LQFP

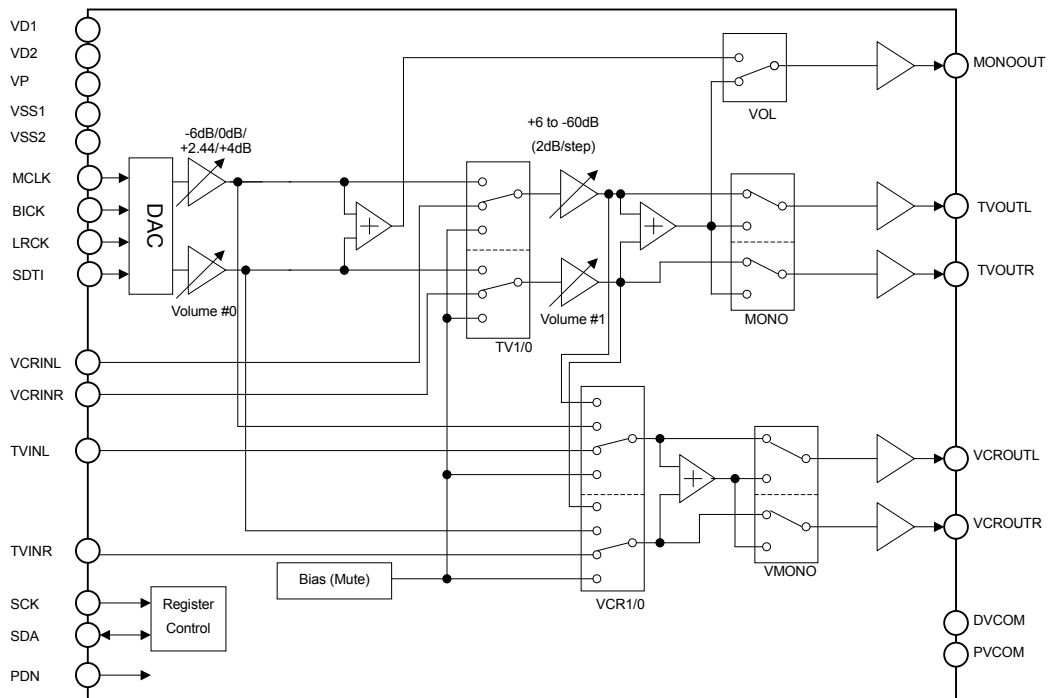

Audio Block(DAPD="0")

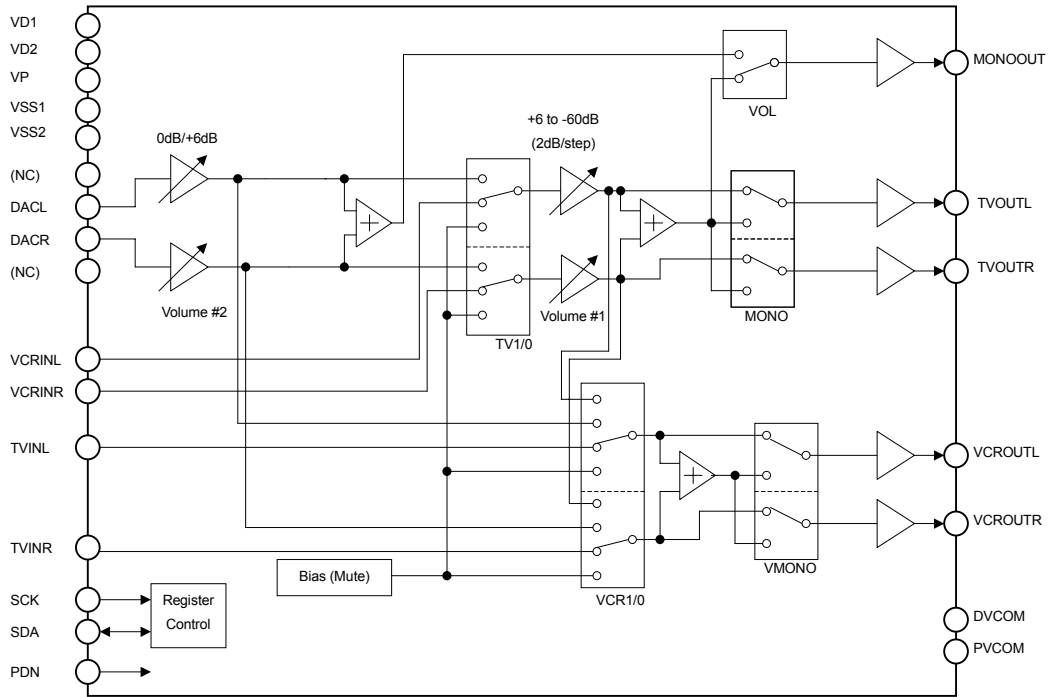

Audio Block(DAPD="1")

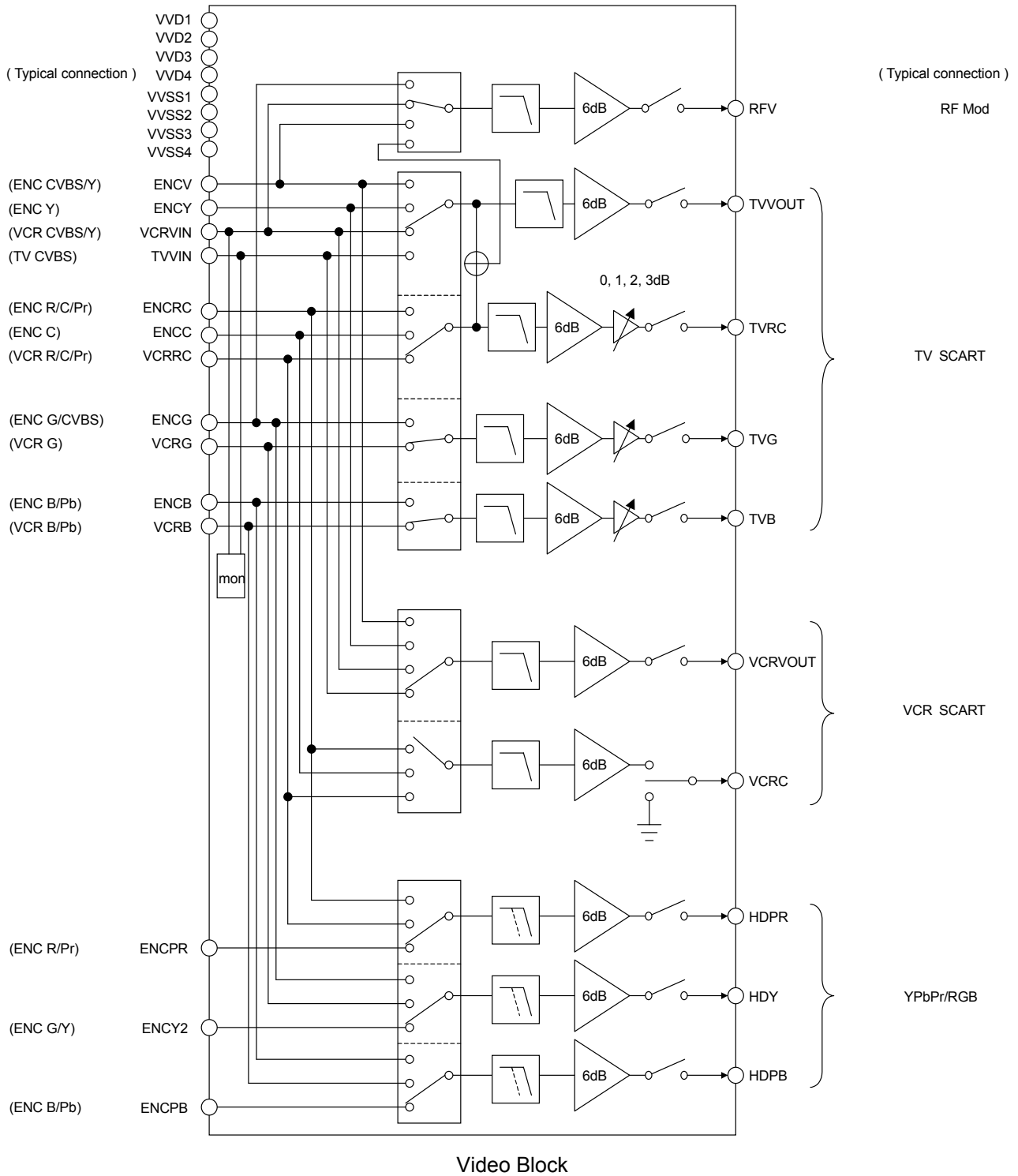

( Typical connection )

( Typical connection )

(VCR FB)

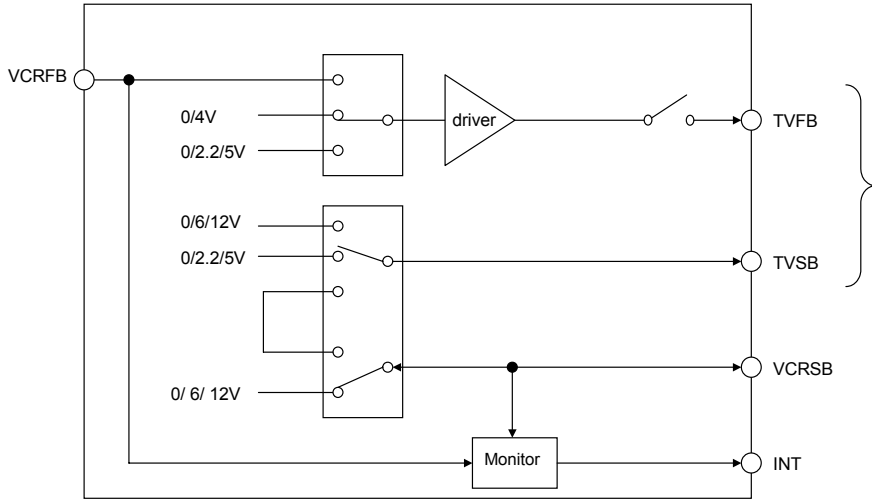

Video Blanking Block

■ Ordering Guide

AK4706VQ      -10 ~ +70°C      64pin LQFP (0.5mm pitch)

■ Pin Layout

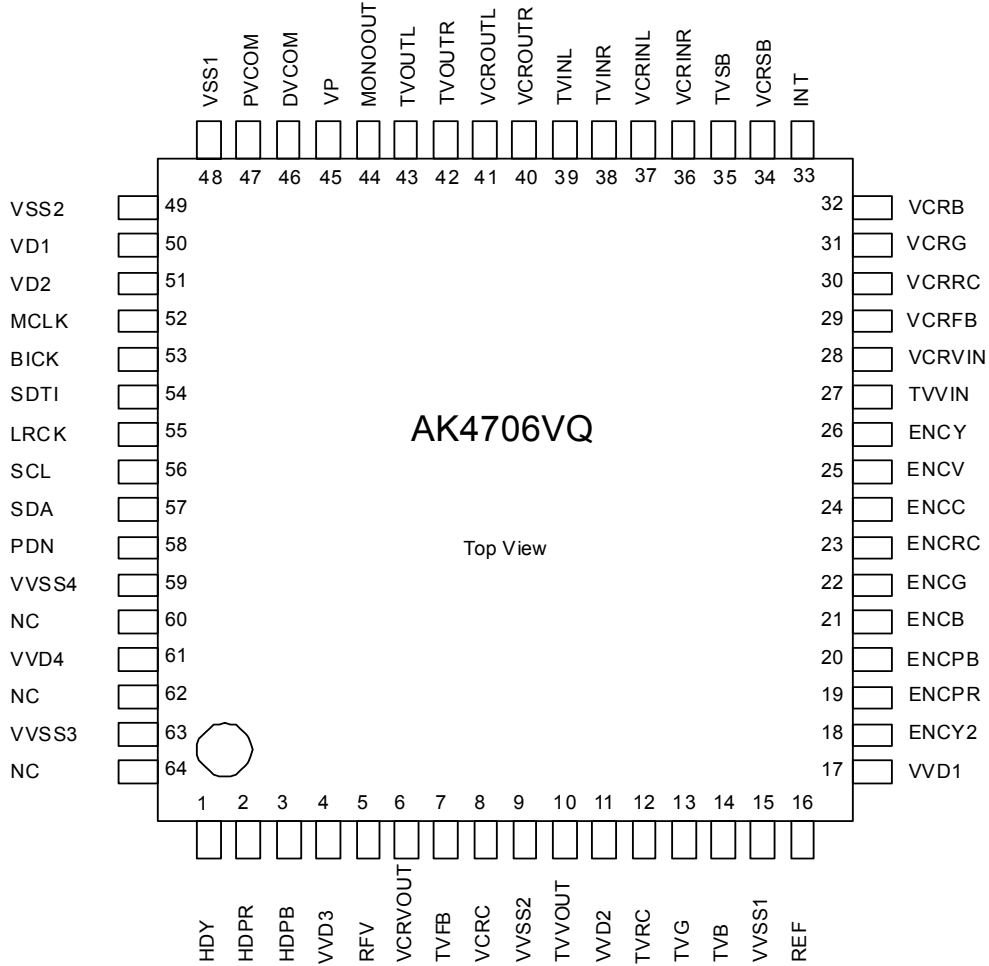

■ Main Difference between AK4705 and AK4706

Items	AK4705	AK4706
HD Video Driver, Filter	-	X
S1/S2 Chroma DC Detector/Generator	-	X
Package	48LQFP	64LQFP

(-: Not available, X: Available)

## PIN/FUNCTION

No.	Pin Name	I/O	Function
1	HDY	O	Green/Y Output Pin
2	HDPR	O	Red/Pr Output Pin
3	HDPB	O	Blue/Pb Output Pin
4	VVD3	-	Video Power Supply Pin #3. 5V. Normally connected to VVSS3 with a 0.1 $\mu$ F ceramic capacitor in parallel with a 10 $\mu$ F electrolytic cap.
5	RFV	O	Composite Output Pin for RF modulator
6	VCRVOUT	O	Composite/Luminance Output Pin for VCR
7	TVFB	O	Fast Blanking Output Pin for TV
8	VCRC	O	Chrominance Output Pin for VCR
9	VVSS2	-	Video Ground Pin #2. 0V.
10	TVVOUT	O	Composite/Luminance Output Pin for TV
11	VVD2	-	Video Power Supply Pin #2. 5V. Normally connected to VVSS with a 0.1 $\mu$ F ceramic capacitor in parallel with a 10 $\mu$ F electrolytic cap.
12	TVRC	O	Red/Chrominance/Pr Output Pin for TV
13	TVG	O	Green/Y Output Pin for TV
14	TVB	O	Blue/Pb Output Pin for TV
15	VVSS1	-	Video Ground Pin #1. 0V.
16	REFI	O	Video Current Reference Setup Pin Normally connected to VVD1 through a 10k $\Omega$ $\pm$ 1% resistor externally.
17	VVD1	-	Video Power Supply Pin #1. 5V. Normally connected to VVSS with a 0.1 $\mu$ F ceramic capacitor in parallel with a 10 $\mu$ F electrolytic cap.
18	ENCY2	I	Green/Y Input Pin for Encoder
19	ENCPR	I	Red/Chrominance/Pr Input Pin for Encoder
20	ENCPB	I	Blue/Pb Input Pin for Encoder
21	ENCB	I	Blue/Pb Input Pin for Encoder
22	ENCG	I	Green/Y Input Pin for Encoder
23	ENCRC	I	Red/Chrominance/Pr Input Pin for Encoder
24	ENCC	I	Chrominance Input Pin for Encoder
25	ENCV	I	Composite/Luminance Input1 Pin for Encoder
26	ENCY	I	Composite/Luminance Input2 Pin for Encoder
27	TVVIN	I	Composite/Luminance Input Pin for TV
28	VCRVIN	I	Composite/Luminance Input Pin for VCR
29	VCRFB	I	Fast Blanking Input Pin for VCR
30	VCRRC	I	Red/Chrominance/Pr Input Pin for VCR
31	VCRG	I	Green/Y Input Pin for VCR
32	VCRB	I	Blue/Pb Input Pin for VCR
33	INT	O	Interrupt Pin for Video Blanking Normally connected to VD(5V) through 10k $\Omega$ resistor externally.
34	VCRSB	I/O	Slow Blanking Input/Output Pin for VCR
35	TVSB	O	Slow Blanking Output Pin for TV
36	VCRINR	I	Rch VCR Audio Input Pin
37	VCRINL	I	Lch VCR Audio Input Pin
38	TVINR	I	Rch TV Audio Input Pin
39	TVINL	I	Lch TV Audio Input Pin
40	VCROUTR	O	Rch VCR Audio Output Pin
41	VCROUTL	O	Lch VCR Audio Output Pin
42	TVOUTR	O	Rch TV Audio Output Pin
43	TVOUTL	O	Lch TV Audio Output Pin

## PIN/FUNCTION (Continued)

44	MONOOUT	O	MONO Analog Output Pin
45	VP	-	Power Supply Pin. 12V. Normally connected to VSS with a 0.1μF ceramic capacitor in parallel with a 10μF electrolytic cap.
46	DVCOM	O	DAC Common Voltage Pin Normally connected to VSS with a 0.1μF ceramic capacitor in parallel with a 10μF electrolytic cap.
47	PVCOM	O	Audio Common Voltage Pin Normally connected to VSS1 with a 0.1μF ceramic capacitor in parallel with a 10μF electrolytic cap. The caps affect the settling time of audio bias level.
48	VSS1	-	Ground Pin. 0V.
49	VSS2	-	Ground Pin. 0V.
50	VD1	-	Power Supply Pin. 5V. Normally connected to VSS2 with a 0.1μF ceramic capacitor in parallel with a 10μF electrolytic cap.
51	VD2	-	Power Supply Pin. 5V. Normally connected to VSS with a 0.1μF ceramic capacitor in parallel with a 10μF electrolytic cap.
52	MCLK	I	Master Clock Input Pin at DAPD= "0".
	(NC)	-	No Connect pin at DAPD="1". This pin should be open.
53	BICK	I	Audio Serial Data Clock Pin at DAPD= "0".
	DACR	I	Rch Analog Audio Input Pin at DAPD= "1".
54	SDTI	I	Audio Serial Data Input Pin at DAPD= "0".
	(NC)	-	No Connect pin at DAPD= "1". This pin should be open.
55	LRCK	I	L/R Clock Pin at DAPD= "0".
	DACL	I	Lch Analog Audio Input Pin at DAPD= "1".
56	SCL	I	Control Data Clock Pin
57	SDA	I/O	Control Data Pin
58	PDN	I	Power-Down Mode Pin When at "L", the AK4706 is in the power-down mode and is held in reset. The AK4706 should always be reset upon power-up.
59	VVSS4	-	Video Ground Pin #4. 0V.
60	NC	-	No Connect pin. This pin should be connected to VSS1.
61	VVD4	-	Video Power Supply Pin #4. 5V. Normally connected to VVSS3 with a 0.1μF ceramic capacitor in parallel with a 10μF electrolytic cap.
62	NC	-	No Connect pin. This pin should be connected to VSS1.
63	VVSS3	-	Video Ground Pin #3. 0V.
64	NC	-	No Connect pin. This pin should be connected to VSS1.

### ■ Handling of Unused Pin

The unused I/O pins should be processed appropriately as below.

Classification	Pin Name	Setting
Analog	HDY, HDPR, HDPB, VCRC, TVVOUT, TVRC, TVG, TVB, ENCY2, ENCPR, ENCPB, ENCB, ENCG, ENCR, ENCC, ENCV, ENCY, TVVIN, VCRVIN, VCRRC, VCRG, VCRB, VCRINR, VCRINL, TVINR, TVINL, VCROUTR, VCROUTL, TVOUTR, TVOUTL, MONOOUT, DACR, DACL, RFV, VCRVOUT	These pins should be open.
Digital	VCRSB (O), TVFB, TVSB VCRFB, VCRSB (I), MCLK, BICK, SDTI, LRCK, SCL, SDA, INT	These pins should be open. These pins should be connected to VSS2.

**INTERNAL EQUIVALENT CIRCUITS**

Pin No.	Pin Name	Type	Equivalent Circuit	Description
52 53 54 55 56 58	MCLK BICK SDTI LRCK SCL PDN	Digital IN (DAPD="0")  Analog IN (DAPD="1")		The 60kΩ is attached only for BICK pin and LRCK pin.
57	SDA	Digital I/O		I2C Bus voltage must not exceed VD2.
33	INT	Digital OUT		Normally connected to VVD1(5V) through 10kΩ resistor externally.
5 6 7 8 10 12 13 14	RFV VCROUT TVFB VCRC TVVOUT TVRC TVG TVB	Video OUT		
1 2 3	HDY HDPR HDPB	Video OUT		
16	REFI	REFI IN		Normally connected to VVD1 through a 10kΩ ±1% resistor.

Pin No.	Pin Name	Type	Equivalent Circuit	Description
18 19 20 21 22 23 24 25 26 27 28 29 30 31 32	ENCY2 ENCPR ENCPB ENCB ENCG ENCRC ENCC ENCV ENCY TVVIN VCRVIN VCRFB VCRRC VCRG VCRB	Video IN		
34 35	VCRSB TVSB	Video SB		The 120kΩ is not attached for TVSB pin and SDC bit = "H".
36 37 38 39	VCRINR VCRINL TVINR TVINL	Audio IN		
40 41 42 43 44	VCROUTR VCROUTL TVOUTR TVOUTL MONOOUT	Audio OUT		
46 47	DVCOM PVCOM	VCOM OUT		

**ABSOLUTE MAXIMUM RATINGS**(VSS1=VSS2=VVSS1=VVSS2=VVSS3=VVSS4=0V; [Note 1](#))

Parameter	Symbol	min	max	Units
Power Supply	VD1	-0.3	6.0	V
	VD2	-0.3	6.0	V
	VVD1	-0.3	6.0	V
	VVD2	-0.3	6.0	V
	VVD3	-0.3	6.0	V
	VVD4	-0.3	6.0	V
	VP	-0.3	14	V
	VSS1-VVSS4  <a href="#">(Note 2)</a>	-	0.3	V
	VSS1-VVSS3  <a href="#">(Note 2)</a>	-	0.3	V
	VSS1-VVSS2  <a href="#">(Note 2)</a>	-	0.3	V
VSS1-VVSS1  <a href="#">(Note 2)</a>	-	0.3	V	
VSS1-VSS2  <a href="#">(Note 2)</a>	-	0.3	V	
Input Current (any pins except for supplies)	IIN	-	±10	mA
Input Voltage <a href="#">(Note 3)</a>	VIND	-0.3	VD2+0.3	V
Video Input Voltage <a href="#">(Note 4)</a>	VINV	-0.3	VVD1+0.3	V
Audio Input Voltage (except DACL/R pins)	VINA	-0.3	VP+0.3	V
Audio Input Voltage (DACL/R pins)	VINA	-0.3	VD2+0.3	V
Ambient Operating Temperature	Ta	-10	70	°C
Storage Temperature	Tstg	-65	150	°C

Note 1. All voltages with respect to ground.

Note 2. VSS1, VSS2, VVSS1, VVSS2, VVSS3 and VVSS4 must be connected to the same analog ground plane.

Note 3. MCLK, BICK, SDTI, LRCK, SCL, PDN pins

Note 4. ENCY2, ENCPR, ENCPB, ENCB, ENCG, ENCR, ENCC, ENCV, ENCY, TVVIN, VCRVIN, VCRFB, VCRRC, VCRG, VCRB pins

WARNING: Operation at or beyond these limits may result in permanent damage to the device.

Normal operation is not guaranteed at these extremes.

**RECOMMENDED OPERATING CONDITIONS**(VSS1=VSS2=VVSS1=VVSS2=VVSS3=VVSS4=0V; [Note 1](#))

Parameter	Symbol	min	typ	max	Units
Power Supply <a href="#">(Note 5)</a>	VD1	4.75	5.0	5.25	V
	VD2	4.75	5.0	VD1	V
	VVD1	4.75	5.0	5.25	V
	VVD2	4.75	5.0	VVD1	V
	VVD3	4.75	5.0	VVD1	V
	VVD4	4.75	5.0	VVD1	V
	VP	11.4	12	12.6	V

Note 5. Analog output voltage scales with the voltage of VD1.

AOUT (typ@0dB) = 2Vrms × VD1/5.

The VVD1 and VVD2 must be the same voltage.

\*AKM assumes no responsibility for the usage beyond the conditions in this datasheet.

<b>ELECTRICAL CHARACTERISTICS</b>
-----------------------------------

(Ta = 25°C; VP=12V, VD1=VD2=5V; VVD1=VVD2=VVD3=VVD4=5V; fs = 48kHz; BICK = 64fs)

<b>Power Supplies</b>				
Parameter	min	typ	max	Units
<b>Power Supply Current</b>				
Normal Operation (PDN pin = "H"; <a href="#">Note 6</a> )				
VD1+VD2		17		mA
VVD1+VVD2+ VVD3+VVD4		90		mA
VD1+VD2+ VVD1+VVD2+ VVD3+VVD4			150	mA
VP		6	12	mA
Power-Down Mode (PDN pin = "L"; <a href="#">Note 7</a> )				
VD1+VD2		10	100	μA
VVD1+VVD2+ VVD3+VVD4		10	100	μA
VP		10	100	μA

Note 6. STBY bit = "L", all video outputs are active.

No signal, no load for A/V switches. fs=48kHz "0" data input for DAC.

Note 7. All digital inputs including clock pins (MCLK, BICK and LRCK) are held at VD2 or VSS2.

<b>DIGITAL CHARACTERISTICS</b>
--------------------------------

(Ta = 25°C; VD1=VD2= 4.75 ~ 5.25V)

Parameter	Symbol	min	typ	max	Units
High-Level Input Voltage	VIH	2.0	-	-	V
Low-Level Input Voltage	VIL	-	-	0.8	V
Low-Level Output Voltage (SDA pin: Iout= 3mA, INT pin: Iout= 1mA)	VOL	-	-	0.4	V
Input Leakage Current	Iin	-	-	± 100	μA

**ANALOG CHARACTERISTICS (AUDIO)**

(Ta = 25°C; VP=12V, VD1=VD2=5V; VVD1=VVD2=VVD3=VVD4=5V; fs = 48kHz; BICK = 64fs; Signal Frequency = 1kHz; 24bit Input Data; Measurement frequency = 20Hz ~ 20kHz; RL ≥4.5kΩ; Volume #0=Volume #1=0dB, 0dB=2Vrms output; unless otherwise specified)

Parameter	min	typ	max	Units
<b>DAC Resolution</b>			24	bit
<b>Analog Input: (TVINL/TVINR/VCRINL/VCRINR pins)</b>				
<b>Analog Input Characteristics</b>				
Input Voltage			2	Vrms
Input Resistance	100	150	-	kΩ
<b>Analog Input: (DACL/DACR pin)</b>				
<b>Analog Input Characteristics</b>				
Input Voltage			1	Vrms
Input Resistance	40	60	-	kΩ
<b>Stereo/Mono Output: (TVOUTL/TVOUTR/VCROUTL/VCROUTR/MONOOUT pins; Note 8)</b>				
<b>Analog Output Characteristics</b>				
Volume#0 Gain (DAPD bit = "0")				
(DVOL1-0 = "00")	-	0	-	dB
(DVOL1-0 = "01")	-	-6	-	dB
(DVOL1-0 = "10")	-	+2.44	-	dB
(DVOL1-0 = "11". Note 9)	-	+4	-	dB
Volume#2 Gain (DAPD bit = "1")				
(DVOL1-0 = "00")	5.3	6.0	6.7	dB
(DVOL1-0 = "01")	-0.7	0	0.7	dB
Volume#1 Step Width (+6dB to -12dB)	1.6	2	2.4	dB
(-12dB to -40dB)	0.5	2	3.5	dB
(-40dB to -60dB)	0.1	2	3.9	dB
THD+N (at 2Vrms output. Note 10)		-86	-80	dB
(at 3Vrms output. Note 10, Note 11)		-60	-	dB
Dynamic Range (-60dB Output, A-weighted. Note 10)	92	96		dB
S/N (A-weighted. Note 10)	92	96		dB
Interchannel Isolation (Note 10, Note 12)	80	90		dB
Interchannel Gain Mismatch (Note 10, Note 12)	-	0.3	-	dB
Gain Drift	-	200	-	ppm/°C
Load Resistance (AC-Load; Note 13)				
TVOUTL/R, VCROUTL/R, MONOOUT	4.5			kΩ
Load Capacitance				
TVOUTL/R, VCROUTL/R, MONOOUT			20	pF
Output Voltage (Note 13, Note 14)	1.85	2	2.15	Vrms
Power Supply Rejection (PSR. Note 15)	-	50		dB

Note 8. Measured by Audio Precision System Two Cascade.

Note 9. Output clips over -2.5dBFS digital input.

Note 10. DAC to TVOUT

Note 11. Except VCROUTL/VCROUTL pins.

Note 12. Between TVOUTL and TVOUTR with digital inputs 1kHz/0dBFS.

Note 13. THD+N: -80dB(min. at 2Vrms), -60dB(typ. at 3Vrms).

Note 14. Full-scale output voltage by DAC (0dBFS). Output voltage of DAC scales with the voltage of VD1,

Stereo output (typ@0dBFS) = 2Vrms × VD1/5 when volume#0=volume#1=0dB. The output must not exceed 3Vrms.

Note 15. The PSR is applied to VD1 with 1kHz, 100mV.

<b>FILTER CHARACTERISTICS</b>
-------------------------------

(Ta = 25°C; VP=11.4~12.6V, VD1=VD2=4.75~5.25V, VVD1=VVD2=VVD3=VVD4=4.75~5.25V; fs = 48kHz; DEM0 = "1", DEM1 = "0")

Parameter		Symbol	min	typ	max	Units
<b>Digital filter</b>						
Passband	±0.05dB	(Note 16)	PB	0	24.0	21.77
	-6.0Db			-		-
Stopband		(Note 16)	SB	26.23		kHz
Passband Ripple			PR		± 0.01	dB
Stopband Attenuation			SA	64		dB
Group Delay		(Note 17)	GD	-	24	-
<b>Digital Filter + LPF</b>						
Frequency Response	0 ~ 20.0kHz		FR	-	± 0.5	-
						dB

Note 16. The passband and stopband frequencies scale with fs.

e.g.) PB=0.4535×fs (@±0.05dB), SB=0.546×fs.

Note 17. The calculating delay time which occurred by digital filtering. This time is from setting the 16/18/24bit data of both channels to input register to the output of analog signal.

**ANALOG CHARACTERISTICS (SD VIDEO)**

(Ta = 25°C; VP=12V, VD1=VD2=5V; VVD1=VVD2=VVD3=VVD4=5V; VVOL1/0= "00", unless otherwise specified.)

Parameter	Conditions	min	typ	max	Units	
Sync Tip Clamp Voltage	at output pin.		0.7		V	
Chrominance Bias Voltage	at output pin.		2.2		V	
R/G/B Clamp Voltage	at output pin.		0.7		V	
Pb/Pr Clamp Voltage	at output pin.		2.2		V	
Gain	Input=0.3Vp-p, 100kHz	5.5	6	6.5	dB	
RGB Gain	Input=0.3Vp-p, 100kHz	VVOL1/0= "00"	5.5	6	6.5	dB
		VVOL1/0= "01"	6.7	7.2	7.7	dB
		VVOL1/0= "10"	7.7	8.2	8.7	dB
		VVOL1/0= "11"	8.6	9.1	9.6	dB
Interchannel Gain Mismatch	TVRC, TVG, TVB. Input=0.3Vp-p, 100kHz	-0.5	-	0.5	dB	
Frequency Response	Input=0.3Vp-p, C1=C2=0pF. 100kHz to 6MHz.		-1.0	0.5	dB	
		at 10MHz.		-3	dB	
		at 27MHz.		-40	-25	dB
Group Delay Distortion	At 4.43MHz with respect to 1MHz.			15	ns	
Input Impedance	Chrominance input (internally biased)	40	60	-	kΩ	
Input Signal	f=100kHz, distortion < 1.0%, gain=6dB	-	-	1.5	Vpp	
Load Resistance	(Note 18)	150	-	-	Ω	
Load Capacitance	C1 (Note 18)			400	pF	
	C2 (Note 18)			15	pF	
Dynamic Output Signal	f=100kHz, distortion < 1.0%	-	-	3	Vpp	
Y/C Crosstalk	f=4.43MHz, 1Vp-p input. Among TVVOUT, TVRC, VCRVOUT and VCRC outputs.	-	-50	-	dB	
S/N	Reference Level = 0.7Vp-p, CCIR 567 weighting. BW= 15kHz to 5MHz.	-	74	-	dB	
Differential Gain	0.7Vpp 5steps modulated staircase. chrominance &burst are 280mVpp, 4.43MHz.	-	+0.3	-	%	
Differential Phase	0.7Vpp 5steps modulated staircase. chrominance &burst are 280mVpp, 4.43MHz.	-	+0.6	-	Degree	

Note 18. Refer the [Figure 1](#).

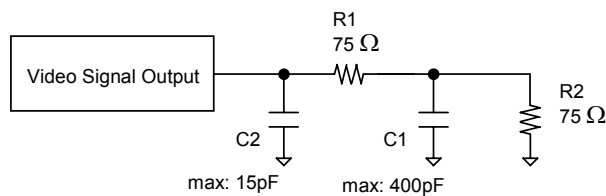

Figure 1. Load Resistance R1+R2 and Load Capacitance C1/C2.

<b>ANALOG CHARACTERISTICS (HD VIDEO)</b>
--

(Ta = 25°C; VP=12V, VD1=VD2=5V; VVD1=VVD2=VVD3=VVD4=5V; VVOL1/0= "00", unless otherwise specified.)

Parameter	Conditions	min	typ	max	Units	
Sync Tip Clamp Voltage	at output pin.		0.7		V	
R/G/B Clamp Voltage	at output pin.		0.7		V	
Pb/Pr Clamp Voltage	at output pin.		2.2		V	
Gain	Input=0.3Vp-p, 100kHz	5.5	6	6.5	dB	
Frequency response	Input=0.3Vp-p, C1=C2=0pF (Note 18)	FL1/0,FLPB1/0,FLPR1/0= "10" 100kHz to 20MHz, at 30MHz. at 74.25MHz.	-1.0	-2.5 -40	1.0 -25	dB dB dB
		FL1/0,FLPB1/0,FLPR1/0= "01" 100kHz to 15MHz, at 54MHz.	-1.0	-40	1.0 -25	dB dB
		FL1/0,FLPB1/0,FLPR1/0= "00" 100kHz to 6MHz, at 27MHz.	-1.0	-40	0.5 -25	dB dB
Input Signal	f=100kHz, distortion < 1.0%, gain=6dB	-	-	1.5	Vpp	
Load Resistance	(Figure 1)	150	-	-	Ω	
Load Capacitance	C1 (Figure 1)			400	pF	
	C2 (Figure 1)			10	pF	
Dynamic Output Signal	f=100kHz, distortion < 1.0%	-	-	3	Vpp	
Differential Gain	0.7Vpp 5steps modulated staircase. chrominance &burst are 280mVpp, 4.43MHz. FL1/0,FLPB1/0,FLPR1/0= "00"	-	+0.3	-	%	
Differential Phase	0.7Vpp 5steps modulated staircase. chrominance &burst are 280mVpp, 4.43MHz. FL1/0,FLPB1/0,FLPR1/0= "00"	-	+0.6	-	Degree	

## SWITCHING CHARACTERISTICS

(Ta = 25°C; VP=11.4 ~ 12.6V, VD1=VD2=4.75 ~ 5.25V, VVD1=VVD2=VVD3=VVD4=4.75 ~ 5.25V; CL = 20pF)

Parameter	Symbol	Min	typ	max	Units
<b>Master Clock Frequency</b> 256fs:	fCLK	8.192		12.8	MHz
Duty Cycle	dCLK	40		60	%
384fs:	fCLK	12.288		19.2	MHz
Duty Cycle	dCLK	40		60	%
<b>LRCK Frequency</b>	fs	32		50	kHz
Duty Cycle	Duty	45		55	%
<b>Audio Interface Timing</b>					
BICK Period	tBCK	312.5			ns
BICK Pulse Width Low	tBCKL	100			ns
Pulse Width High	tBCKH	100			ns
BICK “↑” to LRCK Edge (Note 19)	tBLR	50			ns
LRCK Edge to BICK “↑” (Note 19)	tLRB	50			ns
SDTI Hold Time	tSDH	50			ns
SDTI Setup Time	tSDS	50			ns
<b>Control Interface Timing (I<sup>2</sup>C Bus):</b>					
SCL Clock Frequency	fSCL	-		400	kHz
Bus Free Time Between Transmissions	tBUF	1.3		-	μs
Start Condition Hold Time (prior to first clock pulse)	tHD:STA	0.6		-	μs
Clock Low Time	tLOW	1.3		-	μs
Clock High Time	tHIGH	0.6		-	μs
Setup Time for Repeated Start Condition	tSU:STA	0.6		-	μs
SDA Hold Time from SCL Falling (Note 20)	tHD:DAT	0		-	μs
SDA Setup Time from SCL Rising	tSU:DAT	0.1		-	μs
Rise Time of Both SDA and SCL Lines	tR	-		0.3	μs
Fall Time of Both SDA and SCL Lines	tF	-		0.3	μs
Setup Time for Stop Condition	tSU:STO	0.6		-	μs
Pulse Width of Spike Noise Suppressed by Input Filter	tSP	0		50	ns
<b>Reset Timing</b>					
PDN Pulse Width (Note 21)	tPD	150			ns

Note 19. BICK rising edge must not occur at the same time as LRCK edge.

Note 20. Data must be held for sufficient time to bridge the 300 ns transition time of SCL.

Note 21. The AK4706 should be reset by PDN pin = “L” upon power up.

Note 22. I<sup>2</sup>C-bus is a trademark of NXP B.V.

■ Timing Diagram

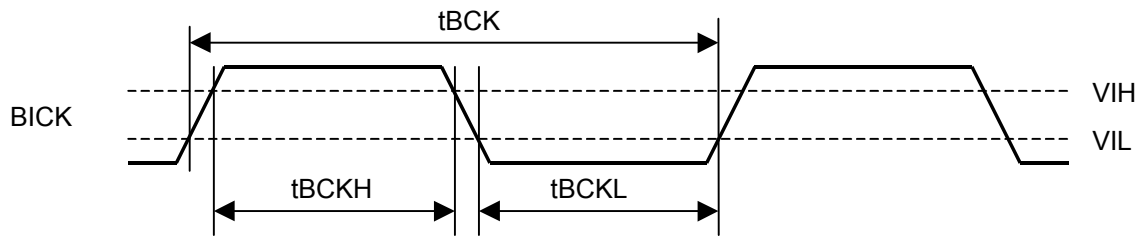
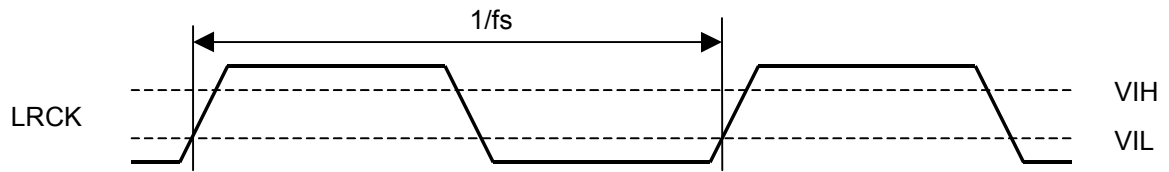
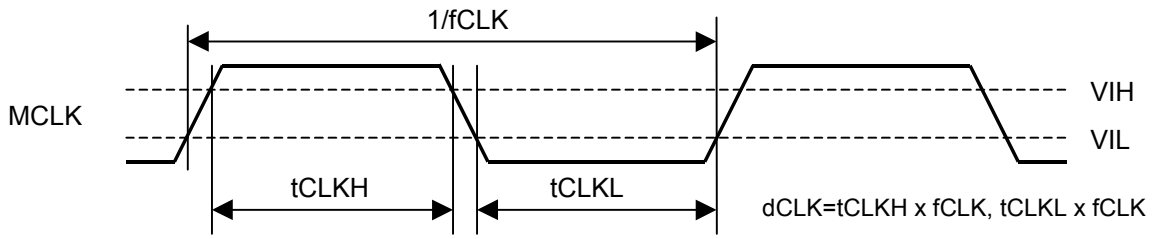

Clock Timing

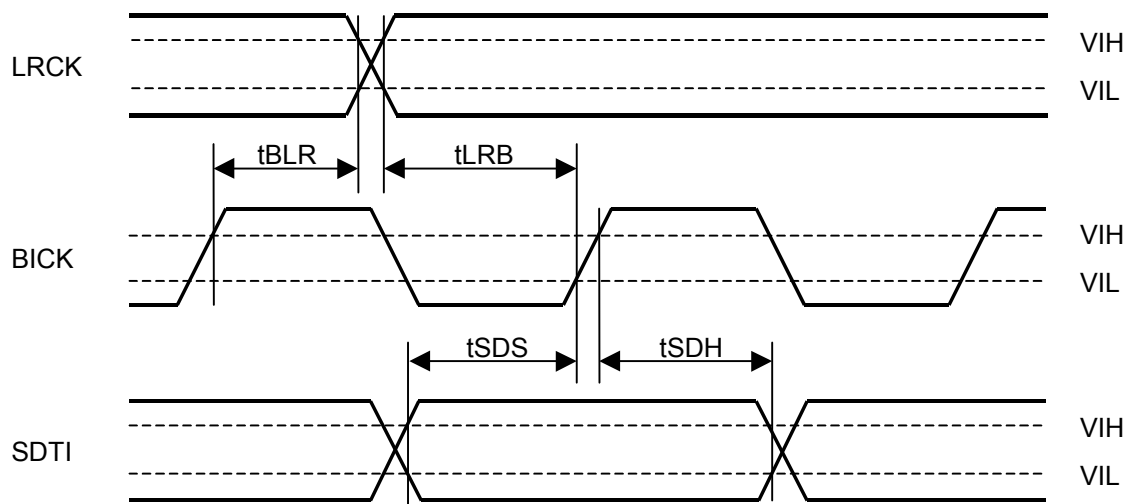

Serial Interface Timing

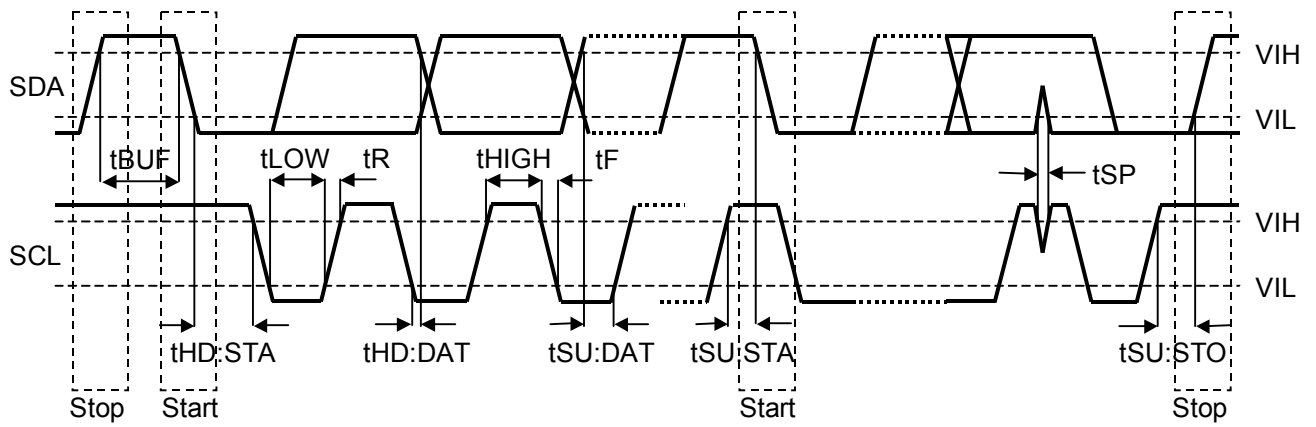

I<sup>2</sup>C Bus mode Timing

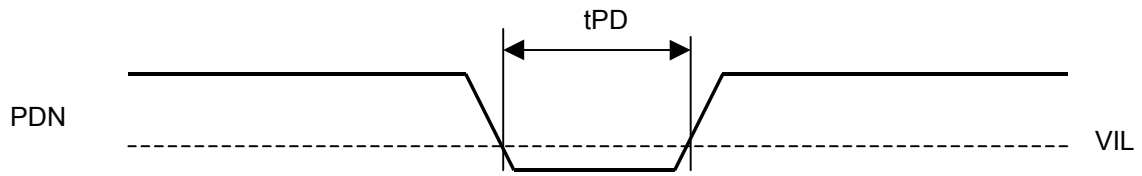

Power-down Timing

<b>OPERATION OVERVIEW</b>
---------------------------

## 1. System Reset and Power-down options

The AK4706 should be reset once by bringing PDN pin = “L” upon power-up. The AK4706 has several operation modes. The PDN pin, AUTO bit, DAPD bit, MUTE bit and STBY bit control operation modes as shown in [Table 1](#) and [Table 2](#).

Mode	PDN pin	AUTO bit	STBY bit	MUTE bit	DAPD bit	Mode
0	“L”	*	*	*	*	Full Power-down
1	“H”	1	*	*	*	Auto Startup mode (default)
2	“H”	0	1	1	*	Standby & mute
3	“H”	0	1	0	*	Standby
4	“H”	0	0	1	1	Mute (DAC power down)
5	“H”	0	0	1	0	Mute (DAC operation)
6	“H”	0	0	0	1	Normal operation (DAC power down & Analog input)
7	“H”	0	0	0	0	Normal operation (DAC operation)

(\*: Don't Care)

Table 1. Operation Mode Settings

Mode	Register Control	Audio			Video Output					
		DAC	MCLK, BICK, LRCK	Audio Bias Level	Video Signal	TVFB, TVSB	VCRSB			
0	Full Power-down	NOT available	Power down	Not needed	Power down	Hi-Z	Hi-Z	Pull-down (2)		
1	Auto Startup mode No video input	Available	Power down	Not needed	Active	Active (4)	Active	Active		
	Auto Startup mode Video input (3)									
2	Standby & mute				Power down	Active	Power down	Hi-Z/Active	Active	Active
3	Standby				Active					
4	Mute1				Power down	Active (1)	Power down	Active (1)	Active	Active
5	Mute2									
6	Normal operation (DAC power down & Analog input)				Power down	Not needed	Active (1)	Active (1)	Active	Active
7	Normal operation (DAC operation)	Active	Needed	Power down	Active (1)	Active	Active			

Notes:

- (1) TVOUTL/R are muted by VMUTE bit in the default state.
- (2) Internally pulled down by 120kohm(typ) resistor.
- (3) Video input to TVVIN or VCRVIN.
- (4) VCRC outputs 0V for termination.  
HD Video output does not work. (Hi-Z default)

Table 2. Status of each operation modes

■ System Reset and Full Power-down Mode

The AK4706 should be reset once by bringing PDN pin = “L” upon power-up.

- PDN pin: Power down pin
- “H”: Normal operation
- “L”: Device power down.

■ Auto Startup Mode

When the PDN pin is set to “H”, the AK4706 is in the auto startup mode. In this mode, all blocks except for the video detection circuit are powered down. Once the video detection circuit detects video signal from TVVIN pin or VCRVIN pin, the AK4706 goes to the stand-by mode (Both Fast Blanking and Slow Blanking are also fixed to VCR-TV Loop-through) automatically and sends “H” pulse via INT pin. To exit the auto startup mode, set the AUTO bit to “0”. The HD video outputs in the auto startup mode are disable at power-up. In this mode, HD video outputs are controlled as shown in Table 3.

- AUTO bit (00H D3): Auto startup bit (SD Video output)
- “1”: Auto startup enable (default).
- “0”: Auto startup disable (Manual startup).

- HDAPW bit (0AH D5): Auto startup bit (HD Video output)
- “1”: Auto startup enable.
- “0”: Auto startup disable (Manual startup: default).

AUTO bit	HDAPW bit	HD Video output
0	0	Set by HDSW1/0, HDCP1/0 bit
0	1	Hi-Z
1	0	Hi-Z
1	1	Set by HDSW1/0, HDCP1/0 bit after a video signal is detected.

Table 3. HD Video output status

The Figure 2 shows an example of the system timing at auto startup mode.

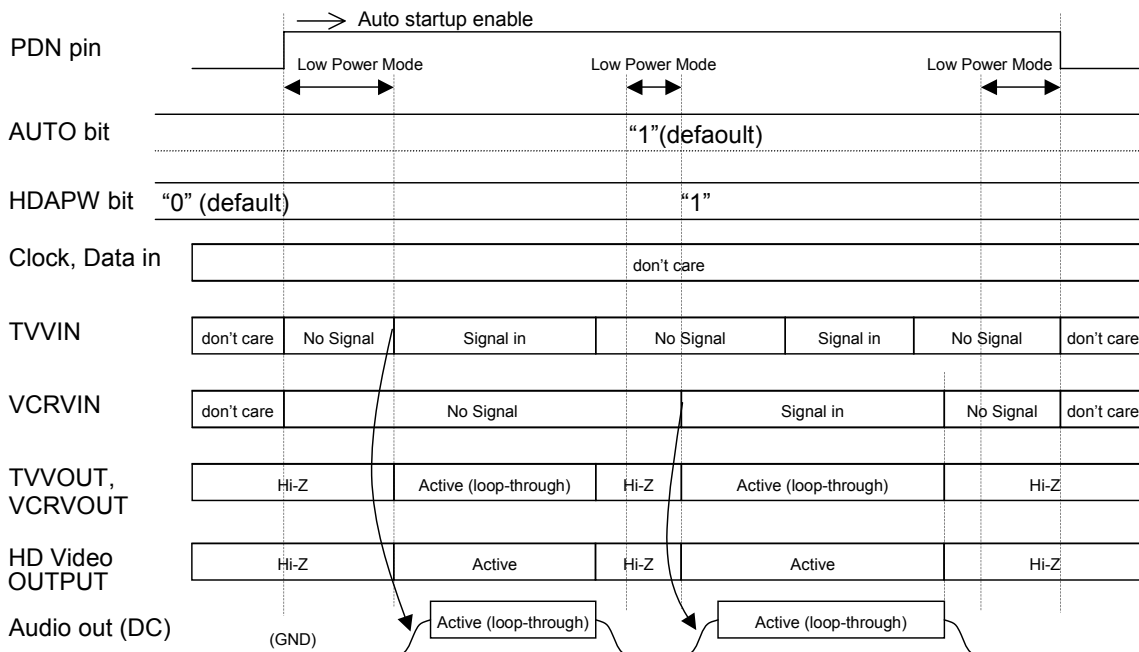

Figure 2. Auto startup mode sequence

### ■ DAC Power-down Mode

The internal DAC block can be powered-down and switched to 1Vrms analog input mode. When DAPD bit =“1”, the zero-cross detection and offset calibration does not work.

DAPD bit (00H D2): DAC power-down bit.

- “1”: DAC power-down. Analog-input mode.
  - #52 pin: MCLK → Unused pin. This pin should be open.
  - #53 pin: BICK → DACR. Rch analog input.
  - #54 pin: SDTI → Unused pin. This pin should be open.
  - #55 pin: LRCK → DACL. Lch analog input.
- “0”: DAC operation. (default)

### ■ Standby Mode

When the AUTO bit = MUTE bit = “0” and the STBY bit = “1”, the AK4706 is forced into TV-VCR loop through mode. In this mode, the sources of TVOUTL/R and MONOOUT pins are fixed to VCRINL/R pins; the sources of VCROUTL/R are fixed to TVINL/R pins respectively. The gain of volume#1 is fixed to 0dB. All register values themselves are NOT changed by STBY bit = “1”.

STBY bit (00H D0): Standby bit.

- “1”: Standby mode. (default)
- “0”: Normal operation.

### ■ Mute Mode (Bias-off Mode. 00H: D1)

When the MUTE bit = “1”, the bias voltage on the audio output goes to GND level. Bringing MUTE bit to “0” changes this bias voltage smoothly from GND to VP/2 by 2sec(typ.). This removes the huge click noise related the sudden change of bias voltage at power-on. The change of MUTE bit from “1” to “0” also makes smooth transient from VP/2 to GND by 2sec(typ). This removes the huge click noise related the sudden change of bias voltage at power-off.

MUTE bit: Bias-off bit.

- “1”: Set the audio bias to GND. (default)
- “0”: Normal operation

### ■ Normal Operation Mode

To use the DAC or change analog switches, set the AUTO bit, DAPD bit, MUTE bit and STBY bit to “0”. The DAC is in power-down mode until MCLK and LRCK are input. The AK4706 is in power-down mode until MCLK and LRCK are input. The [Figure 2](#) shows an example of the system timing at the power-down and power-up by PDN pin.

■ Typical Operation Sequence

The Figure 3 shows an example of the system timing.

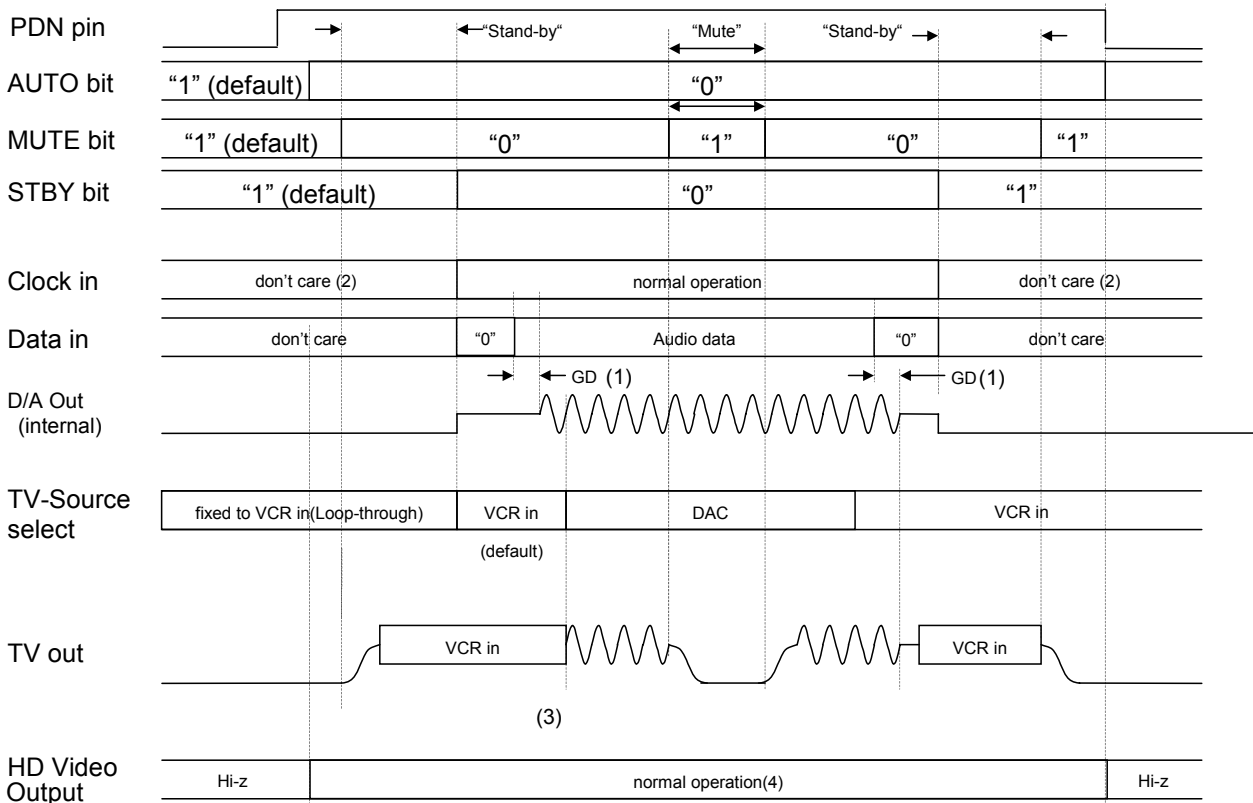

Figure 3. Typical operating sequence (except auto setup mode)

Notes:

- (1) The analog output corresponding to the digital input has a group delay, GD.
- (2) The external clocks (MCLK, BICK and LRCK) can be stopped in standby mode.
- (3) Mute the analog outputs externally if click noise(3) adversely affects the system.
- (4) The HDSW1/0, HDCP1/0 bits set HD video outputs.

## 2. Audio Block

### ■ System Clock

The external clocks required to operate the DAC section of AK4706 are MCLK, LRCK and BICK. The master clock (MCLK) corresponds to 256fs or 384fs. MCLK frequency is automatically detected, and the internal master clock becomes 256fs. The MCLK should be synchronized with LRCK but the phase is not critical. Table 4 illustrates corresponding clock frequencies. All external clocks (MCLK, BICK and LRCK) should always be present whenever the DAC section of AK4706 is in the normal operating mode (STBY bit = "0" and DAPD bit = "0"). If these clocks are not provided, the AK4706 may draw excess current because the device utilizes dynamically refreshed logic internally. The DAC section of AK4706 should be reset by STBY bit = "0" after these clocks are provided. If the external clocks are not present, place the AK4706 in power-down mode (STBY bit = "1"). After exiting reset at power-up etc., the AK4706 remains in power-down mode until MCLK and LRCK are input.

LRCK fs	MCLK		BICK 64fs
	256fs	384fs	
32.0kHz	8.1920MHz	12.2880MHz	2.0480MHz
44.1kHz	11.2896MHz	16.9344MHz	2.8224MHz
48.0kHz	12.2880MHz	18.4320MHz	3.0720MHz

Table 4. System clock example

### ■ Audio Serial Interface Format (00H: D5-D4)

Data is shifted in via the SDTI pin using BICK and LRCK inputs. The DIF0 and DIF1 bits can select four formats in serial mode as shown in Table 5. In all modes, the serial data is MSB-first, 2's complement format and is latched on the rising edge of BICK. Mode 2 can also be used for 16 MSB justified formats by zeroing the unused two LSBs.

Mode	DIF1	DIF0	SDTI Format	BICK	Figure
0	0	0	16bit LSB Justified	≥32fs	Figure 4
1	0	1	18bit LSB Justified	≥36fs	Figure 4
2	1	0	24bit MSB Justified	≥48fs	Figure 5
3	1	1	24bit I <sup>2</sup> S Compatible	≥48fs or 32fs	Figure 6 (default)

Table 5. Audio Data Formats

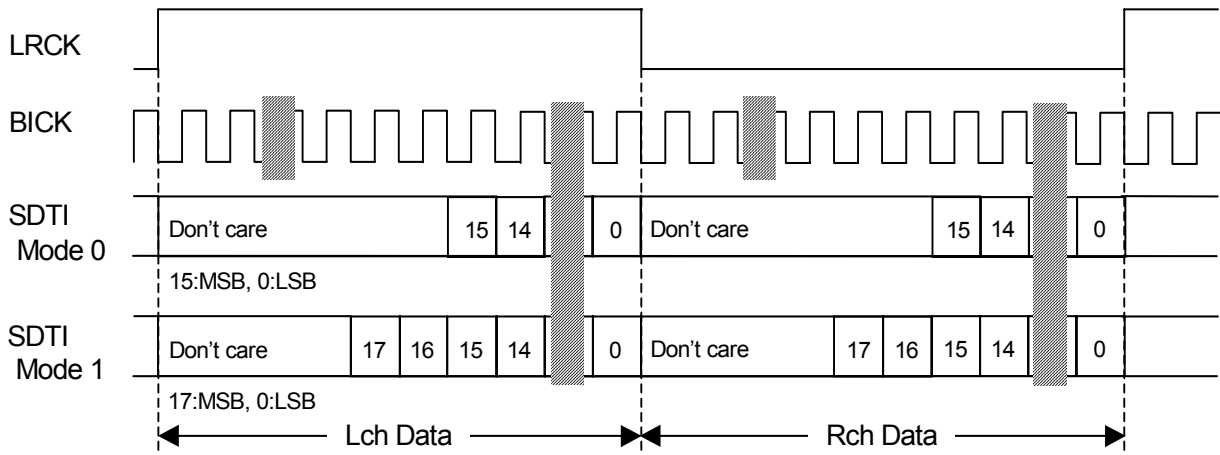

Figure 4. Mode 0,1 Timing

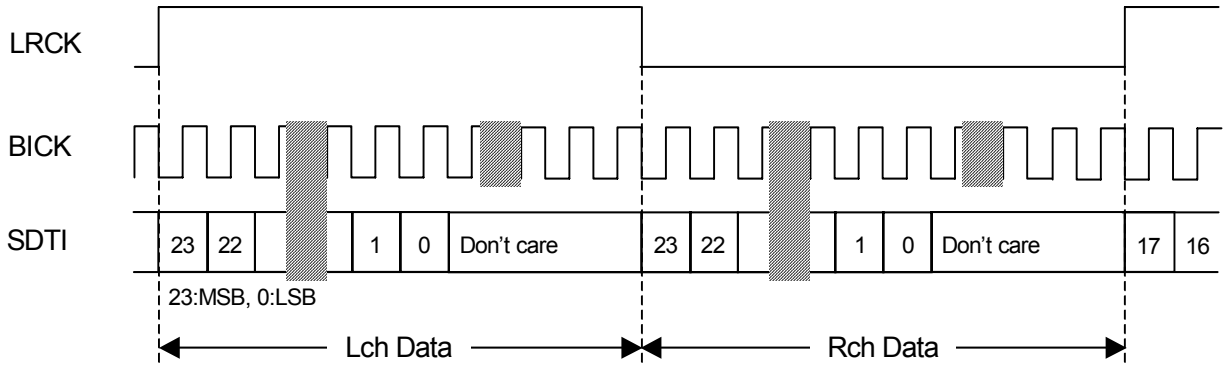

Figure 5. Mode 2 Timing

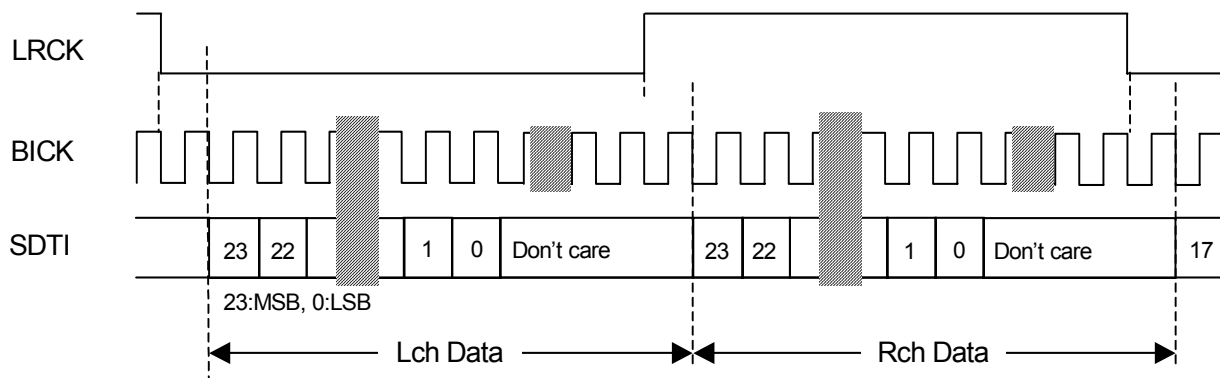

Figure 6. Mode 3 Timing

### ■ De-emphasis filter (00H: D7-D6)

A digital de-emphasis filter is available for 32, 44.1 or 48kHz sampling rates ( $t_c = 50/15\mu s$ ) and is controlled by the DEM0 and DEM1 bits.

DEM1	DEM0	Mode
0	0	44.1kHz
0	1	OFF
1	0	48kHz
1	1	32kHz

(default)

Table 6. De-emphasis filter control

### ■ Switch Control

The AK4706 has switch matrixes designed primarily for SCART routing. Those are controlled via the control register as shown in Table 7, Table 8 and Table 9 (refer to the block diagram).

(01H: D1-D0)

TV1	TV0	Source of TVOUTL/R
0	0	DAC
0	1	VCRIN (default)
1	0	Mute
1	1	(Reserved)

Table 7. TVOUT Switch Configuration

(01H: D2-D0)

VOL	TV1	TV0	Source of MONOOUT
0	0	0	DAC (L+R)/2
0	0	1	DAC (L+R)/2
0	1	0	DAC (L+R)/2
0	1	1	(Reserved)
1	0	0	DAC (L+R)/2
1	0	1	VCRIN (L+R)/2
1	1	0	Mute
1	1	1	(Reserved)

Table 8. MONOOUT Switch Configuration

(01H: D5-D4)

VCR1	VCR0	Source of VCROUTL/R
0	0	DAC
0	1	TVIN (default)
1	0	Mute
1	1	Output of volume #1

Table 9. VCROUT Switch Configuration

### ■ Volume Control #0, #2 (4-Level Volume)

The AK4706 has a 4-level volume control (Volume #0, #2) as shown in Table 10 and Table 11. The volume reflects the change of register value immediately.

(03H: D4-D3)

DVOL1	DVOL0	Volume #0 Gain	Output Level (Typ)
0	0	0dB	2Vrms (with 0dBFS input & volume #1=0dB.)
0	1	-6dB	1Vrms (with 0dBFS input & volume #1=0dB.)
1	0	+2.44dB	2.65Vrms (with 0dBFS input & volume #1=0dB.)
1	1	+4dB	2Vrms (with -10dBFS input & volume #1=+6dB. Clips over -2.5dBFS digital input.)

Table 10. Volume #0 (at DAPD bit ="0". DAC mode)

(03H: D4-D3)

DVOL1	DVOL0	Volume #2 Gain	Output Level (Typ)
0	0	+6dB	2Vrms (with 1Vrms input & volume #1=0dB.)
0	1	0dB	1Vrms (with 1Vrms input & volume #1=0dB.)
1	0	(reserved)	-
1	1	(reserved)	-

Table 11. Volume #2 (at DAPD bit ="1". analog input mode.)

■ Volume Control #1 (Main Volume)

The AK4706 has main volume control (Volume #1) as shown in Table 12.

(02H: D5-D0)

L5	L4	L3	L2	L1	L0	Gain
1	0	0	0	1	0	+6dB
1	0	0	0	0	1	+4dB
1	0	0	0	0	0	+2dB
0	1	1	1	1	1	0dB (default)
...	...	...	...	...	...	...
0	0	0	0	0	1	-60dB
0	0	0	0	0	0	Mute

Note: The output must not exceed 3Vrms.

Table 12. Volume #1

When the MOD bit = "1"(default), changing levels don't have pop noise. MDT1-0 bits select the transition time (see Table 13). When the new gain value 1EH(-2dB) is written to gain resistor while the actual (stable) gain is 1FH(0dB), the gain changes to 1EH(-2dB) within the transition time selected by MDT1-0 bits. The AK4706 compares the actual gain to the value of gain register after finishing the transition time, and re-changes the actual gain to new register value within the transition time if the register value is different from the actual gain when compared. When the MOD bit = "0" then there is no transition time and the gain changes immediately. This change may cause a click noise.

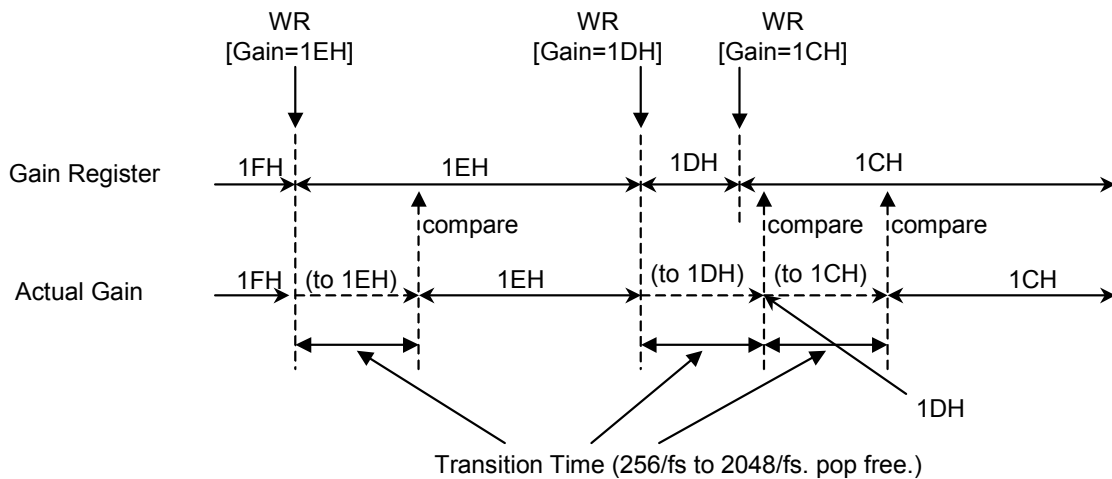

Figure 7. Volume Change Operation (MOD bit = "1")

MDT1	MDT0	Transition Time
0	0	256/fs
0	1	512/fs
1	0	1024/fs
1	1	2048/fs (default)

Table 13. Volume Transition Time

### 3. Video Block

#### ■ Video Switch Control

The AK4706 has switches for TV, VCR and RF modulator. Each switches can be controlled via registers independently. When AUTO bit = "1" or STBY bit = "1", these switch setting are ignored and set to fixed configuration (loop-through mode). Please refer the auto setup mode and standby mode.

(04H: D2-D0)

Mode	VTV2-0 bit	Source of TVVOUT pin	Source of TVRC pin	Source of TVG pin	Source of TVB pin
Shutdown	000	(Hi-Z)	(Hi-Z)	(Hi-Z)	(Hi-Z)
Encoder CVBS+RGB or Encoder YPbPr	001	ENCV pin (Encoder CVBS or Y)	ENCRRC pin (Encoder Red,C or Pb)	ENCG pin (Encoder Green or Y)	ENCB pin (Encoder Blue or Pr)
Encoder Y/C 1	010	ENCV pin (Encoder Y)	ENCRRC pin (Encoder C)	(Hi-Z)	(Hi-Z)
Encoder Y/C 2	011	ENCY pin (Encoder Y)	ENCC pin (Encoder C)	(Hi-Z)	(Hi-Z)
VCR (default)	100	VCRVIN pin (VCR CVBS or Y)	VCRRC pin (VCR Red,C or Pb)	VCRG pin (VCR Green or Y)	VCRB pin (VCR Blue or Pr)
TV CVBS	101	TVVIN pin (TV CVBS)	(Hi-Z)	(Hi-Z)	(Hi-Z)
(reserved)	110	-	-	-	-
(reserved)	111	-	-	-	-

(Refer [Note 23](#), [Note 24](#))

Table 14. TV video output

(04H: D5-D3)

Mode	VVCR2-0 bit	Source of VCRVOUT pin	Source of VCRC pin
Shutdown	000	(Hi-Z)	(Hi-Z)
Encoder CVBS or Y/C 1	001	ENCV pin (Encoder CVBS or Y)	ENCRRC pin (Encoder C)
Encoder CVBS or Y/C 2	010	ENCY pin (Encoder CVBS or Y)	ENCC pin (Encoder C)
TV CVBS (default)	011	TVVIN pin (TV CVBS)	(Hi-Z)
VCR	100	VCRVIN pin (VCR CVBS)	VCRRC pin (VCR C)
(reserved)	101	-	-
(reserved)	110	-	-
(reserved)	111	-	-

(Refer [Note 23](#))

Table 15. VCR video output

(04H: D7-D6)

Mode	VRF1-0 bit	Source of RFV pin
Encoder CVBS1	00	ENCV pin. (Encoder CVBS)
Encoder CVBS2	01	ENCG pin. (Encoder CVBS) (Note 24)
VCR (default)	10	VCRVIN pin. (VCR CVBS)
Shutdown	11	(Hi-Z)

Table 16. RF video output

Note 23. When input the video signal via ENCR pin or VCR pin, set CLAMP1-0 bits respectively.

Note 24. When VTV2-0 bit = "001", TVG bit = "1" and VRF1-0 bit = "01", RFV pin output is same as TVG pin output (Encoder G).

■ Video Output Control (05H: D6-D0)

Each video outputs can be set to Hi-Z individually via control registers. These setting are ignored when the AUTO bit = "1". When the CIO bit = "1", the VCRC pin outputs 0V even if the VCRC bit = "0". When the CIO bit = "0", the VCRC pin follows the setting of VCRC bit. Please refer the "Red/Chroma Bi-directional Control for VCR SCART".

- TVV: TVVOUT output control
- TVR: TVRCOUT output control
- TVG: TVGOUT output control
- TVB: TVBOUT output control
- VCRV: VCRVOUT output control
- VCRC: VCRC output control
- TVFB: TVFB output control

- 0: Hi-Z (default)
- 1: Active.

■ Red/Chroma Bi-directional Control for VCR SCART (05H: D7, D5)

The AK4706 supports the bi-directional Red/Chroma signal on the VCR SCART.

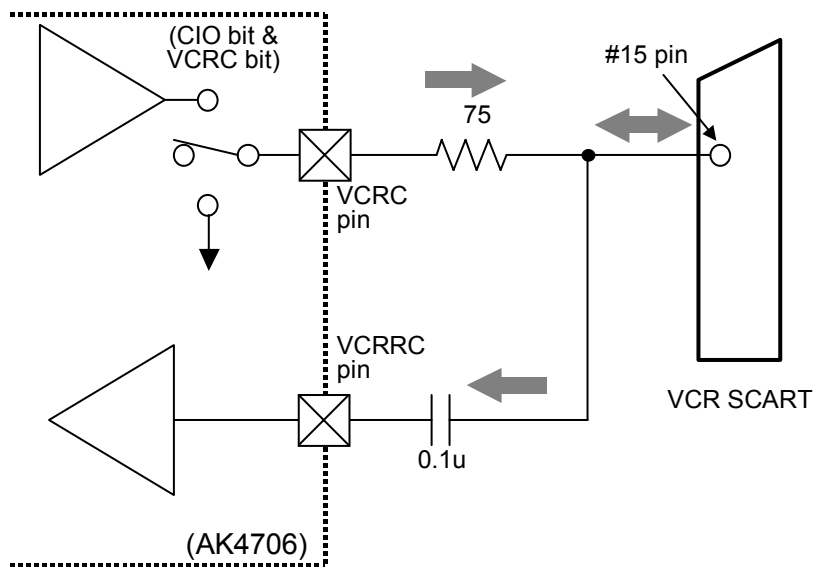

Figure 8. Red/Chroma Bi-directional Control

CIO	VCRC	State of VCRC pin
0	0	Hi-Z (default)
0	1	Active
1	0	Connected to GND
1	1	Connected to GND

Table 17 Red/Chroma Bi-directional Control

### ■ RGB Video Gain Control (06H: D1-D0)

VVOL1-0 bits set the RGB video gain.

VVOL1	VVOL0	Gain	Output level (Typ. @Input=0.7Vpp)
0	0	+6dB	1.4Vpp (default)
0	1	+7.2dB	1.6Vpp
1	0	+8.2dB	1.8Vpp
1	1	+9.1dB	2.0Vpp

Table 18. RGB video gain control

### ■ Clamp and DC-restore circuit control (06H: D7-D2, 0AH: D3)

Each CVBS and Y input has the sync tip clamp circuit. The DC-restore circuit has two clamp voltages 0.7V(typ) and 2.2V(typ) to support both RGB and YPbPr signal. They correspond to 0.35V(typ) and 1.1V(typ) at the SCART connector when matched by 75ohm resistors. The CLAMP1, CLAMP0 and CLAMPB bits select the input circuit for ENCRC pin (Encoder Red/Chroma), ENCB pin (Encoder Blue), VCRC pin (VCR Red/Chroma) and VCRB pin (VCR Blue) respectively. VCLP1-0 bits select the sync source of DC- restore circuit.

CLAMPB	CLAMP0	VCRC Input Circuit	VCRB Input Circuit	VCRG Input Circuit	note
0	0	DC restore (0.7V)	DC restore (0.7V)	DC restore (0.7V)	for RGB
0	1	Biased	DC restore (0.7V)	DC restore (0.7V)	for Y/C (default)
1	0	DC restore (2.2V)	DC restore (2.2V)	Sync Tip Clamp (0.7V)	for YPbPr
1	1	(reserved)	(reserved)	(reserved)	

Table 19. DC-restore control for VCR Input

CLAMPB	CLAMP1	ENCRC Input Circuit	ENCB Input Circuit	note
0	0	DC restore (0.7V)	DC restore (0.7V)	for RGB (default)
0	1	Biased	DC restore (0.7V)	for Y/C
1	0	DC restore (2.2V)	DC restore (2.2V)	for YPbPr
1	1	(reserved)	(reserved)	

Table 20. DC-restore control for Encoder Input

CLAMP2	ENCG Input Circuit	note
0	DC restore (0.7V)	for RGB (default)
1	Sync tip clamp (0.7V)	for YPbPr

Note: When the VTV2-0 bits = "001", TVG bit = "1" and VCLP2-0 bits = "011", Sync tip is selected even if the CLAMP2 bit = "0".

Table 21. DC-restore control for Encoder Green/Y Input

VCLP2-0: DC restore source control

VCLP2	VCLP1	VCLP0	Sync Source of DC Restore
0	0	0	ENCV (default)
0	0	1	ENCY
0	1	0	VCRVIN
0	1	1	ENCG
1	0	0	VCRG
1	0	1	(reserved)
1	1	0	(reserved)
1	1	1	(reserved)

Note: When the AUTO bit = "1", the source is fixed to VCRVIN.

Table 22. DC-restore source control

### ■ HD Video Control (0AH: D7-D6, D1-D0)

FLY1/0, FLPB1/0, FLPR1/0 bits and HDSW1/0, HDCP1/0 bits set the HD video switch and filter response.

HDSW1	HDSW0	HDCP1	HDCP0	HD YPbPr – RGB Control
0	0	0(default)	0(default) /1	YPbPr. ENCY2 = 0.7V Clamp, ENCPB = 2.2V DC-restore, ENCPR = 2.2V DC-restore. (ENCY2= Sync Source only for ENCPB, ENCPR)
0	0	1	0	RGB. ENCY2 = 0.7V Clamp, ENCPB = 0.7V DC-restore, ENCPR = 0.7V DC-restore. (ENCY2= Sync Source only for ENCPB, ENCPR)
0	0	1	1	RGB. ENCY2 = 0.7V DC-restore, ENCPB = 0.7V DC-restore, ENCPR = 0.7V DC-restore. Sync Source = ENCV
0	1	*	*	ENCG, ENCB, ENCR Follow CLAMPB, 2, 1
1	0	*	*	VCRG, VCRB, VCRRC Follow CLAMPB, 0. VCRG follow VCRRC circuit.
1(default)	1(default)	*	*	Hi-Z

Table 23. HD Video Switch Control (3ch common)

Input		Output
FLY1/ FLPB1/FLPR1 bit	FLY0/ FLPB0/FLPR0 bit	LFP response
0	0	6MHz LPF (default)
0	1	12MHz LPF
1	0	30MHz LPF
1	1	(Reserved)

Table 24. HD Video Filter Control (3ch independent)

#### 4. Blanking Control, S1/S2 DC Control

When the SDC bit= "0", the AK4706 supports Fast Blanking signals and Slow Blanking (Function Switching) signals for TV/VCR SCART. When the SDC bit= "1", the AK4706 supports S1/S2 mode.

SDC bit: SCART-S1/S2 Control

0: SCART Fast/Slow Blanking Mode

1: S1/S2 Mode

#### ■ Input/Output Control for Fast/Slow Blanking

FB1-0: TV Fast Blanking output control (0AH: D4, 07H: D1-D0)

Input			Output
SDC bit	FB1 bit	FB0 bit	TVFB pin Output Level
0	0	0	<0.4V (default)
0	0	1	4V<
0	1	0	Same as VCR FB input (4V/0V)
0	1	1	(Reserved)
1	0	0	<0.4V
1	0	1	1.55V to 2.4V
1	1	0	Same as VCR FB input (5V/2.2V/0V)
1	1	1	3.5V<

(Note: Load resistance is min. 150ohm for SDC bit ="0", min. 100kohm for SDC bit ="1")

Table 25. TV Fast Blanking output

SBT1-0: TV Slow Blanking output control (0AH: D4, 07H: D3-D2)

Input			Output
SDC bit	SBT1 bit	SBT0 bit	TVSB pin Output Level
0	0	0	<2V (default)
0	0	1	5V to 7V
0	1	0	(Reserved)
0	1	1	10V<
1	0	0	<0.4V
1	0	1	1.55V to 2.4V
1	1	0	(Reserved)
1	1	1	3.5V<

(Note: Load resistance is min. 10kohm for SDC bit ="0", min. 100kohm for SDC bit ="1")

Table 26. TV Slow Blanking output

SBV1-0: VCR Slow Blanking output control (07H: D5-D4)

SBV1	SBV0	VCRSB pin Output Level
0	0	<2V (default)
0	1	5V to 7V
1	0	(Reserved)
1	1	10V<

(Note: Load resistance is min. 10kohm)

Table 27. VCR Slow Blanking output

SBIO1-0: TV/VCR Slow Blanking I/O control (07H: D7-D6)

SBIO1	SBIO0	VCRSB pin Direction	TVSB pin Direction
0	0	Output (Controlled by SBV1,0)	Output (Controlled by SBT1,0)
0	1	(Reserved)	(Reserved)
1	0	Input (Stored in SVCR1,0)	Output (Controlled by SBT1,0)
1	1	Input (Stored in SVCR1,0)	Output (Same output as VCR SB)

(default)

Table 28. TV/VCR Slow Blanking I/O control

## 5. Monitor Options and INT function

### ■ Monitor Options (08H: D7, D5, D2-D0)

The AK4706 has several detection functions. SVCR1-0 bits, FVCR bit, VCMON bit and TVMON bit reflect the input DC level of VCR slow blanking, the input DC level of VCR fast blanking and signals input to TVVIN or VCRVIN pins.

SDC bit: SCART-S1/S2 Control

0: SCART Fast/Slow Blanking Mode

1: S1/S2 Mode

SVCR1-0 bit: VCR Slow blanking status monitor

SVCR1-0 bits reflect the voltage at VCRSB pin only when the VCRSB pin is in the input mode.

When the VCRSB is in the output mode, SVCR1-0 hold previous value.

Input		Output	
SDC bit	VCRSB pin input level	SVCR1 bit	SVCR0 bit
0	< 2V	0	0
0	4.5 to 7V	0	1
0	(Reserved)	1	0
0	9.5<	1	1
1	< 0.4V	0	0
1	1.4 to 2.4V	0	1
1	(Reserved)	1	0
1	3.5V<	1	1

Note: When SDC bit = "0", VCRSB pin is connected to a Internal pull-down resistor(120kΩ@TYP).

Table 29. VCR Slow Blanking monitor

FVCR: VCR Fast blanking input level monitor

This bit is enabled when TVFB bit = "1".

Input		Output	
SDC bit	VCRFB pin input level	FVCR1 bit	FVCR0 bit
0	<0.4V	0	0
0	1 V<	0	1
0	(Reserved)	0	0
0	(Reserved)	0	0
1	< 0.4V	0	0
1	1.4 to 2.4V	0	1
1	(Reserved)	1	0
1	3.5V<	1	1

Table 30. VCR Fast Blanking monitor (Typical threshold is 0.7V)

VCMON: VCRVIN pin video input monitor (MCOMN bit = "1"),  
 TVVIN pin or VCRVIN pin video input monitor (MCOMN bit = "0")  
 0: No video signal detected.  
 1: Detects video signal.

TVMON: TVVIN pin video input monitor (active when MCOMN bit = "1")  
 0: No video signal detected.  
 1: Detects video signal.

MCOMN (09H D7)	TVVIN signal*	VCRVIN signal*	TVMON (08H D4)	VCMON (08H D3)
0	0	0	0	0
0	0	1	0	1
0	1	0	0	1
0	1	1	0	1
1	0	0	0	0
1	0	1	0	1
1	1	0	1	0
1	1	1	1	1

\*: "0" is No signal.  
 "1" is Signal input

Table 31. TV/VCR Monitor Function

■ INT Function and Mask Options (09H: D7, D4-D1)

Changes of the 08H status can be monitored via the INT pin. The INT pin is the open drain output and goes “L” for 2μsec(typ.) when the status of 08H is changed. This pin should be connected to VD2 (typ. 5V) through 10kohm resistor. MTV bit, MVC bit, MCOMN bit, MFVCR bit and MSVCR bit control the reflection of the status change of these monitors onto the INT pin from report to prevent to masks each monitor.

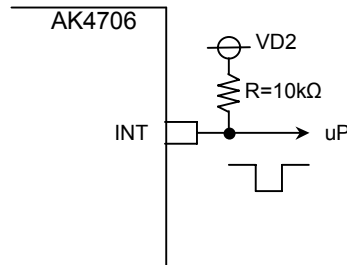

Figure 9. INT pin

MVC: VCMON Mask. Refer [Table 33](#)

MTV: TVMON Mask. Refer [Table 32](#)

MCOMN: Refer [Table 31](#)

AUTO (00H D3)	TVMON (08H D4)	MTV (09H D4)	INT
0	No Change	0	Hi-Z
0	No Change	1	Hi-Z
0	Change	0	Generates “L” Pulse
0	Change	1	Hi-Z
1	No Change	0	Hi-Z
1	No Change	1	Hi-Z
1	Change	0	Generates “L” Pulse
1	Change	1	Generates “L” Pulse

Table 32. TV Monitor Mask

AUTO (00H D3)	VCMON (08H D3)	MVC (09H D3)	INT
0	No Change	0	Hi-Z
0	No Change	1	Hi-Z
0	Change	0	Generates “L” Pulse
0	Change	1	Hi-Z
1	No Change	0	Hi-Z
1	No Change	1	Hi-Z
1	Change	0	Generates “L” Pulse
1	Change	1	Generates “L” Pulse

Table 33. VCR Monitor Mask

MFVCR: FVCR Monitor mask.

0: Change of MFVCR is reflected to INT pin. (default)

1: Change of MFVCR is NOT reflected to INT pin.

MSVCR: SVCR1-0 Monitor mask

0: Change of SVCR1-0 is reflected to INT pin. (default)

1: Change of SVCR1-0 is NOT reflected to INT pin.

## 6. Control Interface

### I<sup>2</sup>C-bus Control Mode

#### 1. WRITE Operations

Figure 10 shows the data transfer sequence in I<sup>2</sup>C-bus mode. All commands are preceded by a START condition. A HIGH to LOW transition on the SDA line while SCL is HIGH indicates a START condition (Figure 16). After the START condition, a slave address is sent. This address is 7 bits long followed by an eighth bit which is a data direction bit (R/W). The most significant seven bits of the slave address are fixed as “0010001”. If the slave address match that of the AK4706, the AK4706 generates the acknowledge and the operation is executed. The master must generate the acknowledge-related clock pulse and release the SDA line (HIGH) during the acknowledge clock pulse (Figure 17). A “1” for R/W bit indicates that the read operation is to be executed. A “0” indicates that the write operation is to be executed. The second byte consists of the address for control registers of the AK4706. The format is MSB first, and those most significant 3-bits are fixed to zeros (Figure 12). The data after the second byte contain control data. The format is MSB first, 8bits (Figure 13). The AK4706 generates an acknowledge after each byte has been received. A data transfer is always terminated by a STOP condition generated by the master. A LOW to HIGH transition on the SDA line while SCL is HIGH defines a STOP condition (Figure 16).

The AK4706 can execute multiple one byte write operations in a sequence. After receipt of the third byte, the AK4706 generates an acknowledge, and awaits the next data again. The master can transmit more than one byte instead of terminating the write cycle after the first data byte is transferred. After the receipt of each data, the internal address counter is incremented by one, and the next data is taken into next address automatically. If the address exceeds 0BH prior to generating the stop condition, the address counter will “roll over” to 00H and the previous data will be overwritten. The data on the SDA line must be stable during the HIGH period of the clock. The HIGH or LOW state of the data line can only change when the clock signal on the SCL line is LOW (Figure 18) except for the START and the STOP condition.

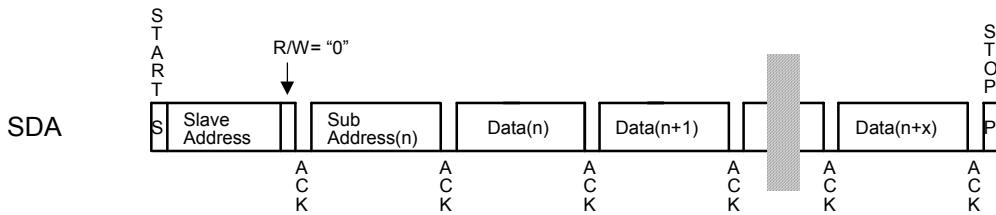

Figure 10. Data transfer sequence at the I<sup>2</sup>C-bus mode

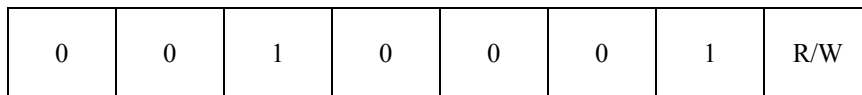

Figure 11. The first byte

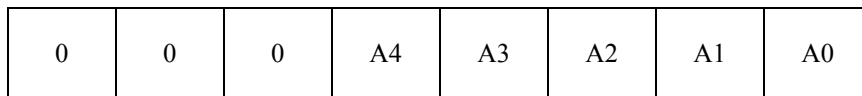

Figure 12. The second byte

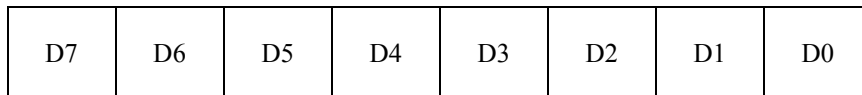

Figure 13. Byte structure after the second byte

2. READ Operations

Set R/W bit = "1" for READ operations. After transmission of data, the master can read the next address's data by generating an acknowledge instead of terminating the write cycle after the receipt the first data word. After the receipt of each data, the internal address counter is incremented by one, and the next data is taken into next address automatically. If the address exceeds 09H prior to generating the stop condition, the address counter will "roll over" to 00H and the previous data will be overwritten.

The AK4706 supports two basic read operations: CURRENT ADDRESS READ and RANDOM READ.

2-1. CURRENT ADDRESS READ

The AK4706 contains an internal address counter that maintains the address of the last word accessed, incremented by one. Therefore, if the last access (either a read or write) was to address n, the next CURRENT READ operation would access data from the address n+1. After receipt of the slave address with R/W bit set to "1", the AK4706 generates an acknowledge, transmits 1byte data which address is set by the internal address counter and increments the internal address counter by 1. If the master does not generate an acknowledge to the data but generate the stop condition, the AK4706 discontinues transmission

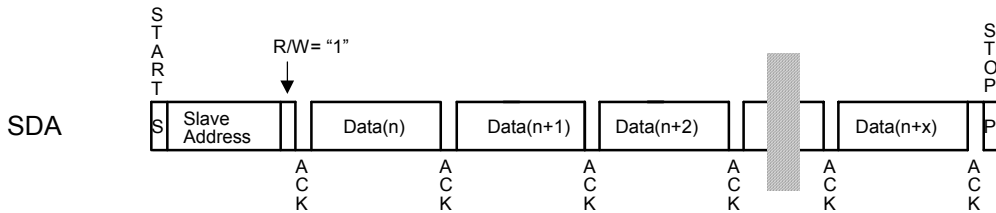

Figure 14. CURRENT ADDRESS READ

2-2. RANDOM READ

Random read operation allows the master to access any memory location at random. Prior to issuing the slave address with the R/W bit set to "1", the master must first perform a "dummy" write operation. The master issues a start condition, slave address(R/W="0") and then the register address to read. After the register's address is acknowledge, the master immediately reissues the start condition and the slave address with the R/W bit set to "1". Then the AK4706 generates an acknowledge, 1-byte data and increments the internal address counter by 1. If the master does not generate an acknowledge to the data but generate the stop condition, the AK4706 discontinues transmission.

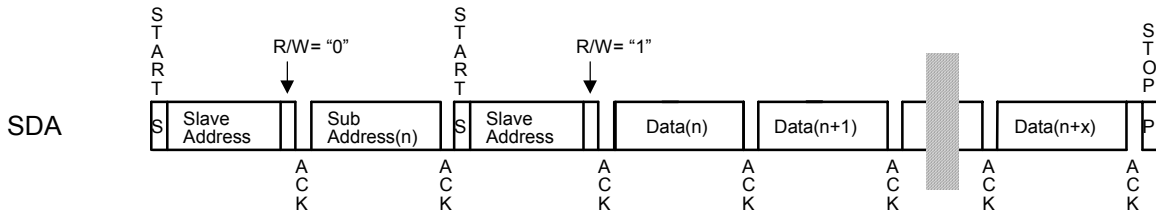

Figure 15. RANDOM ADDRESS READ

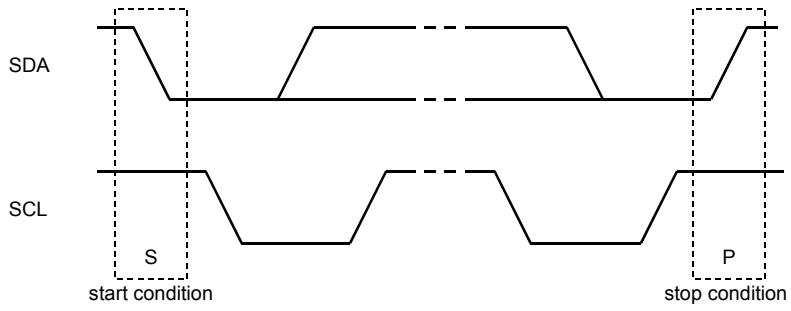

Figure 16. START and STOP conditions

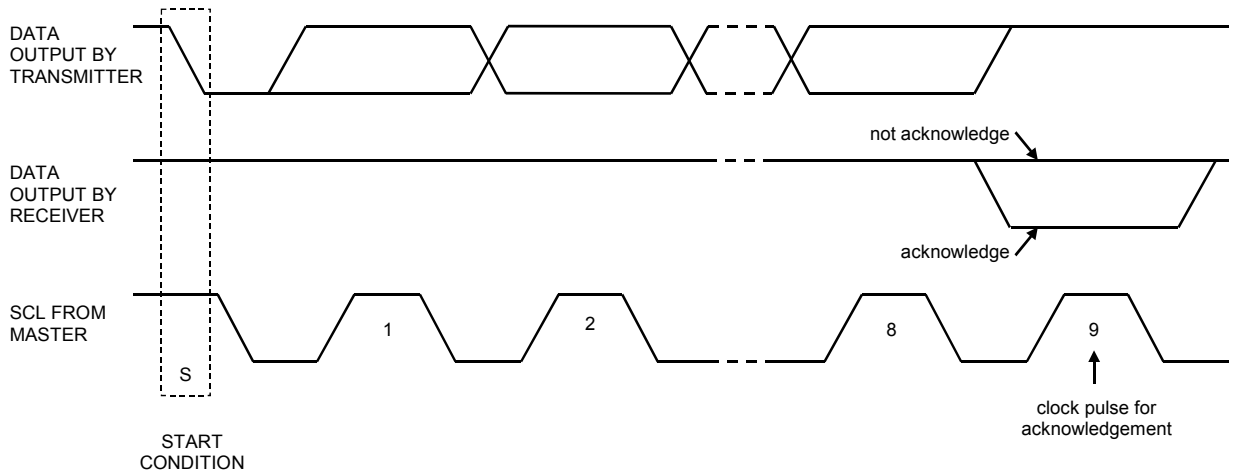

Figure 17. Acknowledge on the I<sup>2</sup>C-bus

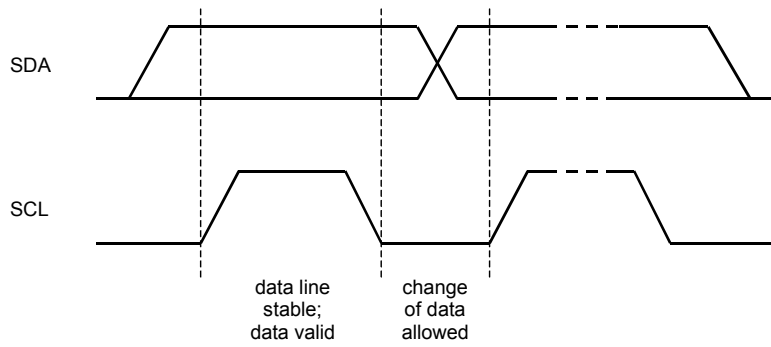

Figure 18. Bit transfer on the I<sup>2</sup>C-bus

## ■ Register Map

Addr	Register Name	D7	D6	D5	D4	D3	D2	D1	D0
00H	Control	DEM1	DEM0	DIF1	DIF0	AUTO	DAPD	MUTE	STBY
01H	Switch	VMUTE	0	VCR1	VCR0	MONO	VOL	TV1	TV0
02H	Main volume	0	0	L5	L4	L3	L2	L1	L0
03H	Zerocross	0	VMONO	1	DVOL1	DVOL0	MOD	MDT1	MDT0
04H	Video switch	VRF1	VRF0	VVCR2	VVCR1	VVCR0	VTV2	VTV1	VTV0
05H	Video output enable	CIO	TVFB	VCRC	VCRV	TVB	TVG	TVR	TVV
06H	Video volume/clamp	CLAMPB	VCLP1	VCLP0	CLAMP2	CLAMP1	CLAMP0	VVOL1	VVOL0
07H	S/F Blanking control	SBIO1	SBIO0	SBV1	SBV0	SBT1	SBT0	FB1	FB0
08H	S/F Blanking monitor	0	0	FVCR1	TVMON	VCMON	FVCR0	SVCR1	SVCR0
09H	Monitor mask	MCOMN	0		MTV	MVC	MFVCR	MSVCR	0
0AH	HD switch	HDCP1	HDCP0	HDAPW	SDC	VCLP2	0	HDSW1	HDSW0
0BH	HD filter	0	0	FLPR1	FLPR0	FLPB1	FLPB0	FLY1	FLY0

When the PDN pin goes “L”, the registers are initialized to their default values.

While the PDN pin =“H”, all registers can be accessed.

Do not write any data to the register over 0BH.

## ■ Register Definitions

Addr	Register Name	D7	D6	D5	D4	D3	D2	D1	D0
00H	Control	DEM1	DEM0	DIF1	DIF0	AUTO	DAPD	MUTE	STBY
	R/W	R/W							
	default	0	1	1	1	1	0	1	1

STBY: Standby control

0: Normal Operation

1: Standby Mode (default)

DAC: powered down and timings are reset.

Gain of Volume#1: fixed to 0dB

Source of TVOUT: fixed to VCRIN

Source of VCROUT: fixed to TVIN

Source of MONOOUT: fixed to VCRIN

Source of TVVOUT: fixed to VCRVIN (or Hi-Z)

Source of TVRC: fixed to VCRRC (or Hi-Z)

Source of TVG: fixed to VCRG (or Hi-Z)

Source of TVB: fixed to VCRB (or Hi-Z)

Source of TVFB: fixed to VCRFB (or Hi-Z)

Source of TVSB: fixed to VCRSB

Source of VCRVOUT: fixed to TVVIN (or Hi-Z)

Source of VCRC: fixed to Hi-Z or VSS (controlled by CIO bit)

MUTE: Audio output control

0: Normal operation

1: All Audio outputs to GND (default)

DAPD: DAC power down control

0: Normal operation (default).

1: DAC power down.

When DAPD bit = "1", the soft transition for volume does not work.

AUTO: Auto startup bit

0: Auto startup disable (Manual startup).

1: Auto startup enable (default).

When the SBIO1bit = "1"(default="0"), the change of AUTO bit may cause a "L" pulse on INT pin.

DIF1-0: Audio data interface format control

00: 16bit LSB Justified

01: 18bit LSB Justified

10: 24bit MSB Justified

11: 24bit I<sup>2</sup>S Compatible (default)

DEM1-0: De-emphasis Response Control

00: 44.1kHz

01: off (default)

10: 48kHz

11: 32kHz

Addr	Register Name	D7	D6	D5	D4	D3	D2	D1	D0
01H	Switch	VMUTE	0	VCR1	VCR0	MONO	VOL	TV1	TV0
	R/W	R/W							
	default	1	0	0	1	0	1	0	1

TV1-0: TVOUTL/R pins source switch

00: DAC

01: VCRINL/R pins (default)

10: MUTE

11: (Reserved)

VOL: MONOOUT pin source switch

0: Bypass the volume (fixed to DAC out)

1: Through the volume (default)

MONO: Mono select for TVOUTL/R pins

0: Stereo. (default)

1: Mono. (L+R)/2

VCR1-0: VCROUTL/R pins source switch

00: DAC

01: TVINL/R pins (default)

10: MUTE

11: Volume #1 output

VMUTE: Mute switch for volume #1

0: Normal operation

1: Mute the volume #1 (default)

Addr	Register Name	D7	D6	D5	D4	D3	D2	D1	D0
02H	Main volume	0	0	L5	L4	L3	L2	L1	L0
	R/W	R/W							
	Default	0	0	0	1	1	1	1	1

L5-0: Volume #1 control

Those registers control both Lch and Rch of Volume #1.

11111 to 100011: (Reserved)

100010: Volume gain = +6dB

100001: Volume gain = +4dB

100000: Volume gain = +2dB

011111: Volume gain = +0dB (default)

011110: Volume gain = -2dB

...

000011: Volume gain = -56dB

000010: Volume gain = -58dB

000001: Volume gain = -60dB

000000: Volume gain = Mute

Addr	Register Name	D7	D6	D5	D4	D3	D2	D1	D0
03H	Zerocross	0	VMONO	1	DVOL1	DVOL0	MOD	MDT1	MDT0
	R/W	R/W							
	Default	0	0	1	0	0	1	1	1

MDT1-0: The control of volume transition time (typ)

- 00: 256/fs
- 01: 512/fs
- 10: 1024/fs
- 11: 2048/fs (default)

MOD: Soft transition enable for volume #1 control

- 0: Disable.  
The volume value changes immediately without soft transition.
- 1: Enable (default)  
The volume value changes with soft transition.

This function is disabled when STBY bit or DAPD bit = "1".

DVOL1-0: Volume #0/Volume #2 control.

Refer the [Table 10](#) and [Table 11](#)

VMONO: Mono select for VCROUTL/R pins

- 0: Stereo. (default)
- 1: Mono. (L+R)/2

Addr	Register Name	D7	D6	D5	D4	D3	D2	D1	D0
04H	Video switch	VRF1	VRF0	VVCR2	VVCR1	VVCR0	VTV2	VTV1	VTV0
R/W		R/W							
Default		1	0	0	1	1	1	0	0

VTV2-0: Selector for TV video output

Refer the [Table 14](#).

VVCR2-0: Selector for VCR video output

Refer the [Table 15](#)

VRF1-0: Selector for RFV pin output

Refer the [Table 16](#).

Addr	Register Name	D7	D6	D5	D4	D3	D2	D1	D0
05H	Output enable	CIO	TVFB	VCRC	VCRV	TVB	TVG	TVR	TVV
R/W		R/W							
Default		0	0	0	0	0	0	0	0

TVV: TVVOUT output control

TVR: TVRCOUT output control

TVG: TVGOUT output control

TVB: TVBOUT output control

VCRV: VCRVOUT output control

VCRC: VCRC output control (refer the [Table 17](#))

TVFB: TVFB output control

0: Hi-Z (default)

1: Active.

When the CIO pin = "1", the VCRC pin is connected to GND even if VCRC= "0".

When the CIO pin = "0", the VCRC pin follows the setting of VCRC bit.

CIO: VCRC pin I/O control

Refer the [Table 17](#).

Addr	Register Name	D7	D6	D5	D4	D3	D2	D1	D0
06H	Video volume	CLAMPB	VCLP1	VCLP0	CLAMP2	CLAMP1	CLAMP0	VVOL1	VVOL0
	R/W	R/W							
	Default	0	0	0	0	0	1	0	0

VVOL1-0: RGB video gain control

- 00: +6dB (default)
- 01: +7.2dB
- 10: +8.2dB
- 11: +9.1dB

CLAMPB, CLAMP2-0: Clamp control.

Refer the [Table 19](#), [Table 20](#) and [Table 21](#).

VCLP1-0: DC restore source control

- 00: ENCV pin (default)
- 01: ENCY pin
- 10: VCRVIN pin
- 11: (Reserved)

When the AUTO bit = "1", the source is fixed to VCRVIN pin.

Addr	Register Name	D7	D6	D5	D4	D3	D2	D1	D0
07H	S/F Blanking	SBIO1	SBIO0	SBV1	SBV0	SBT1	SBT0	FB1	FB0
	R/W	R/W							
	Default	0	0	0	0	0	0	0	0

FB1-0: TV Fast Blanking output control (for TVFB pin)

- 00: 0V (default)
- 01: 4V
- 10: follow VCR FB input (4V/0V)
- 11: (Reserved)

SBT1-0: TV Slow Blanking output control (for TVSB pin. Load resistance is min.10kohm.)

- 00: <2V (default)
- 01: 5V to 7V
- 10: (Reserved)
- 11: 10V<

SBV1-0: VCR Slow Blanking output control (for VCRSB pin. Load resistance is min.10kohm)

- 00: <2V (default)
- 01: 5V to 7V
- 10: (Reserved)
- 11: 10V<

SBIO1-0: TV/VCR Slow Blanking I/O control (refer the [Table 28](#))

Addr	Register Name	D7	D6	D5	D4	D3	D2	D1	D0
08H	Monitor	0	0	FVCR1	TVMON	VCMON	FVCR0	SVCR1	SVCR0
	R/W	READ							
	Default	0	0	0	0	0	0	0	0

SVCR1-0, FVCR1-0: VCR fast blanking/slow blanking monitor

Refer [Table 29](#), [Table 30](#).

VCMON, TVMON: VCR/TV video input monitor

Refer [Table 31](#).

Addr	Register Name	D7	D6	D5	D4	D3	D2	D1	D0
09H	Monitor mask	MCOMN	0	0	MTV	MVC	MFVCR	MSVCR	0
	R/W	R/W							
	default	0	0	0	0	1	0	0	0

MSVCR: SVCR1-0 Monitor mask.

0: The INT pin reflects the change of SVCR1-0 bits. (default)

1: The INT pin does not reflect the change of SVCR1-0 bit.

MFVCR: FVCR Monitor mask.

0: The INT pin reflects the change of MFVCR bit. (default)

1: The INT pin does not reflect the change of MFVCR bit.

MVC, MTV: VCR/TV monitor mask

Refer the [Table 32](#), [Table 33](#).

MCOMN: Monitor mask option

Refer [Table 31](#).

Addr	Register Name	D7	D6	D5	D4	D3	D2	D1	D0
0AH	HD switch	HDCP1	HDCP0	HDAPW	SDC	VCLP2	0	HDSW1	HDSW0
	R/W	R/W							
	default	0	0	0	0	0	0	1	1

HDSW1-0, HDCP1-0: HD video switch.

Refer [Table 23](#).

HDAPW: auto startup bit (HD Video output)

1: Auto startup enable.

0: Auto startup disable (Manual startup: default).

SDC: SCART-S1/S2 DC Control

Refer [Table 25](#), [Table 26](#), [Table 29](#) and [Table 30](#).

VCLP2: DC restored source control

Refer [Table 22](#)

Addr	Register Name	D7	D6	D5	D4	D3	D2	D1	D0
0BH	HD filter	0	0	FLPR1	FLPR0	FLPB1	FLPB0	FLY1	FLY0
	R/W	R/W							
	default	0	0	0	0	0	0	0	0

FLY1-0, FLPB1-0, FLPR1-0: HD Video Filter Control

Refer [Table 24](#).

**SYSTEM DESIGN**

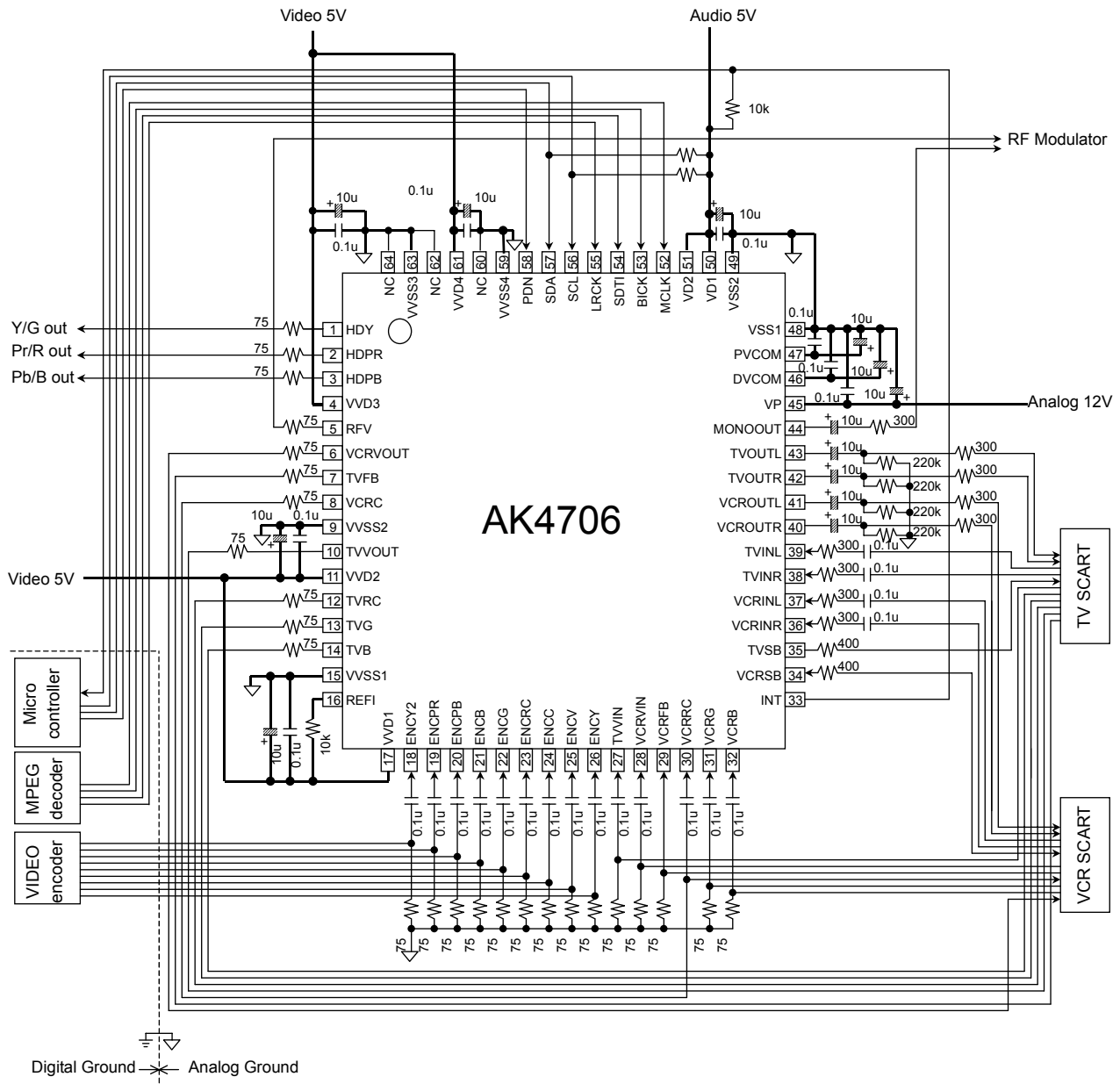

Figure 19. Typical Connection Diagram

## ■ Grounding and Power Supply Decoupling

VD1-2, VP, VVD1-4, VSS1-2 and VVSS1-4 should be supplied from analog supply unit with low impedance and be separated from system digital supply. An electrolytic capacitor 10 $\mu$ F parallel with a 0.1 $\mu$ F ceramic capacitor should be attached to these pins to eliminate the effects of high frequency noise. The 0.1 $\mu$ F ceramic capacitors should be placed as near to VD (VD1-2, VP, VVD1-4) as possible.

## ■ Voltage Reference

DVCOM and PVCOM are signal ground of this chip. An electrolytic capacitor 10 $\mu$ F parallel with a 0.1 $\mu$ F ceramic capacitor should be attached to these VCOM pins to eliminate the effects of high frequency noise. No load current may be drawn from these VCOM pins. All signals, especially clocks, should be kept away from these VCOM pins in order to avoid unwanted coupling into the AK4706.

## ■ Analog Audio Outputs

The analog outputs are also single-ended and centered on 5.6V(typ.). The output signal range is typically 2Vrms (typ@VD1=5V). The internal switched-capacitor filter and continuous-time filter attenuate the noise generated by the delta-sigma modulator beyond the audio pass band. Therefore, any external filters are not required for typical application. The output voltage is a positive full scale for 7FFFFFFH (@24bit) and a negative full scale for 800000H (@24bit). The ideal output is 5.6V(typ.) for 000000H (@24bit). The DC voltage on analog outputs are eliminated by AC coupling.

## ■ REFI pin

The REFI pin is video current reference pin. This pin should be connected to VVD1 through a 10k $\Omega$  $\pm$ 1% resistor externally as shown in the [Figure 20](#). No load current may be drawn from this pin. All signals, especially clocks, should be kept away from this pin in order to avoid unwanted coupling.

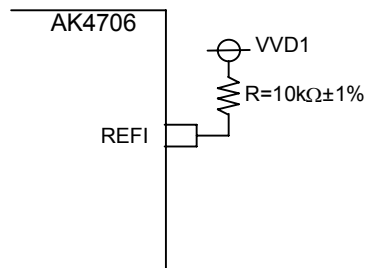
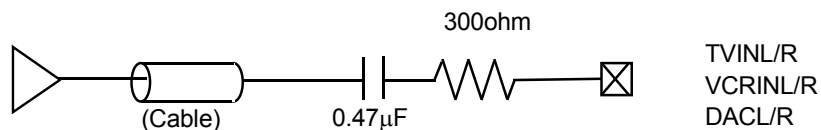

Figure 20. REFI pin

■ External Circuit Example

Analog Audio Input pin



Analog Audio Output pin

MONOOUT  
TVOUTL/R  
VCROUTL/R

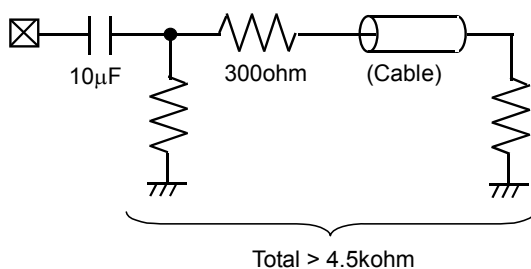

Analog Video Input pin

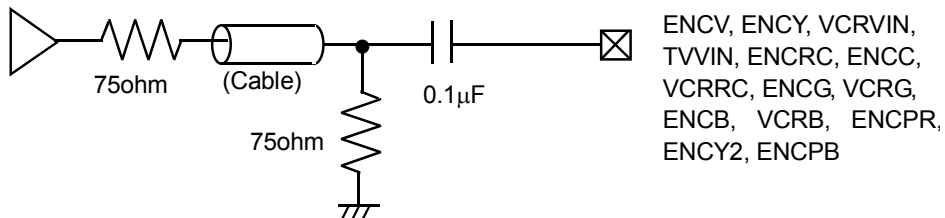

Analog Video Output pin

TVVOUT, TVRC  
TVG, TVR, RFV  
VCRVOUT, VCRC,  
HDPR, HDY,  
HDPB

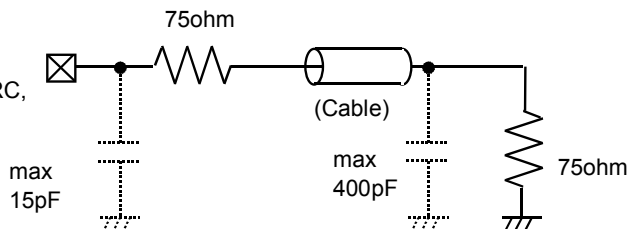

Slow Blanking pin (SDC bit = "0")

TVSB  
VCRSB

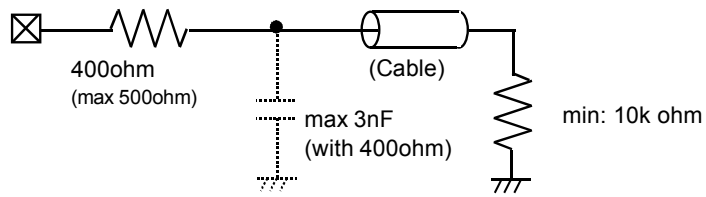

Fast Blanking Input pin (SDC bit = "0")

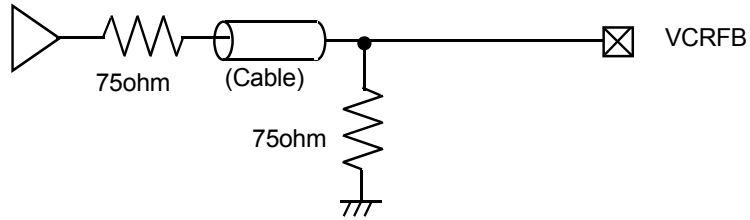

Fast Blanking Output pin (SDC bit = "0")

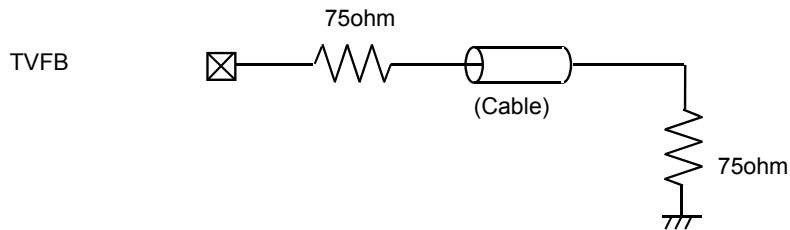

Fast Blanking Output pin (SDC bit = "0")

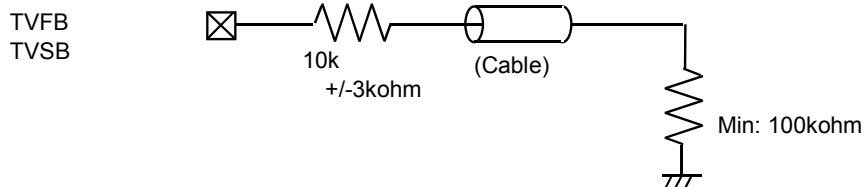

PACKAGE

64pin LQFP (Unit: mm)

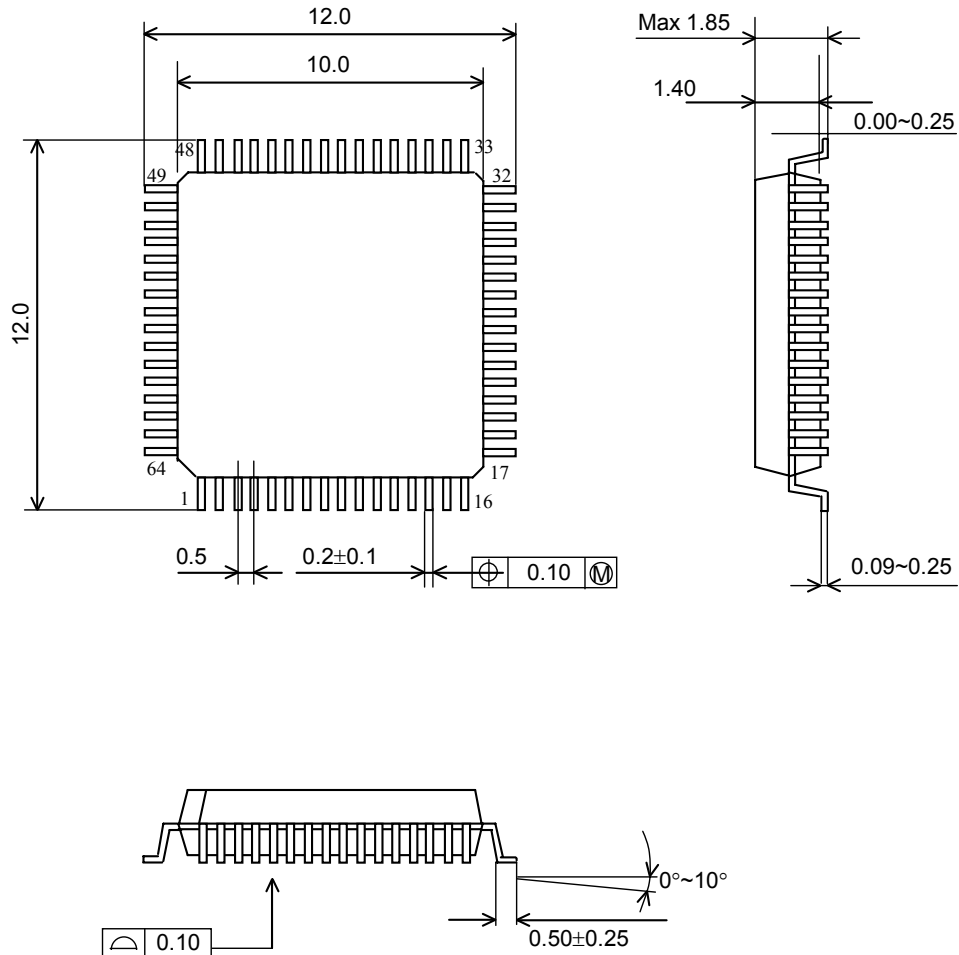

■ Package & Lead frame material

- Package molding compound: Epoxy
- Lead frame material: Cu
- Lead frame surface treatment: Solder (Pb free) plate

**MARKING**

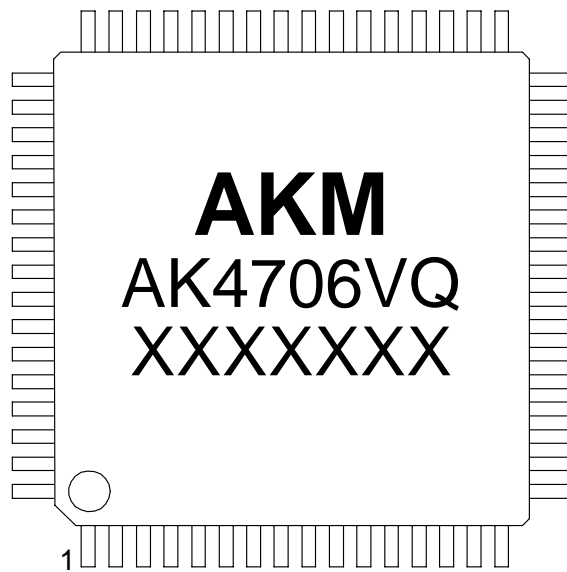

XXXXXXXX: Date code identifier

**REVISION HISTORY**

Date (YY/MM/DD)	Revision	Reason	Page	Contents
06/05/09	00	First Edition		
10/09/17	01	Specification Change	52	PACKAGE The package dimensions were changed.

**IMPORTANT NOTICE**

- These products and their specifications are subject to change without notice.  
When you consider any use or application of these products, please make inquiries the sales office of Asahi Kasei Microdevices Corporation (AKM) or authorized distributors as to current status of the products.
- Descriptions of external circuits, application circuits, software and other related information contained in this document are provided only to illustrate the operation and application examples of the semiconductor products. You are fully responsible for the incorporation of these external circuits, application circuits, software and other related information in the design of your equipments. AKM assumes no responsibility for any losses incurred by you or third parties arising from the use of these information herein. AKM assumes no liability for infringement of any patent, intellectual property, or other rights in the application or use of such information contained herein.
- Any export of these products, or devices or systems containing them, may require an export license or other official approval under the law and regulations of the country of export pertaining to customs and tariffs, currency exchange, or strategic materials.
- AKM products are neither intended nor authorized for use as critical components<sup>Note1)</sup> in any safety, life support, or other hazard related device or system<sup>Note2)</sup>, and AKM assumes no responsibility for such use, except for the use approved with the express written consent by Representative Director of AKM. As used here:
  - Note1) A critical component is one whose failure to function or perform may reasonably be expected to result, whether directly or indirectly, in the loss of the safety or effectiveness of the device or system containing it, and which must therefore meet very high standards of performance and reliability.
  - Note2) A hazard related device or system is one designed or intended for life support or maintenance of safety or for applications in medicine, aerospace, nuclear energy, or other fields, in which its failure to function or perform may reasonably be expected to result in loss of life or in significant injury or damage to person or property.
- It is the responsibility of the buyer or distributor of AKM products, who distributes, disposes of, or otherwise places the product with a third party, to notify such third party in advance of the above content and conditions, and the buyer or distributor agrees to assume any and all responsibility and liability for and hold AKM harmless from any and all claims arising from the use of said product in the absence of such notification.