



AK4708

AV SCART Switch with Two RGB Outputs

GENERAL DESCRIPTION

The AK4708 is an IIC controlled audio and video switch matrix designed for digital TV and set-top-box applications. The AK4708 offers the ideal features for digital set-top-box systems. The AK4708 includes the audio switches, video switches, video filters. The AK4708 provides high performance audio and video routings to meet dual SCART connections. The AK4708 is supplied in a small 48-pin LQFP package to contribute space saving in PCB.

FEATURES

□ Analog Switches for SCART

Audio section

THD+N: -86dB (@2Vrms)

Dynamic Range: 96dB (@2Vrms)

Analog Inputs

Two Full Differential Stereo Inputs or Single-ended input for Decoder DAC

Two Stereo Inputs (TV & VCR SCART)

Analog Outputs

Two Stereo Outputs (TV & VCR SCART)

Stereo Analog Volume with Pop-noise Free Circuit (+6dB to -60dB & Mute)

Pop Noise Free Circuit for Power on/off

Video section

VCR SCART supports RGB mode

Integrated LPF: -40dB @27MHz

75Ω driver

6dB Gain for Outputs

Four CVBS/Y inputs (ENCx2, TV, VCR), Two CVBS/Y outputs (TV, VCR)

Three R/C inputs (ENCx2, VCR), Two R/C outputs (TV, VCR)

Two G and B inputs (ENC, VCR), Two G and B outputs (TV, VCR)

TV/VCR input monitor

Loop-through Mode for standby

Auto-Startup Mode for power saving

SCART pin#16 (Fast Blanking), pin#8 (Slow Blanking) Control

□ Power supply

5V+/-5% and 12V+/-10%

Small current consumption in Standby Mode

(VD=10μA typ., VVD1+VVD2=10μA typ., VP=10μA typ.)

□ Package

48-pin LQFP

■ Block Diagram

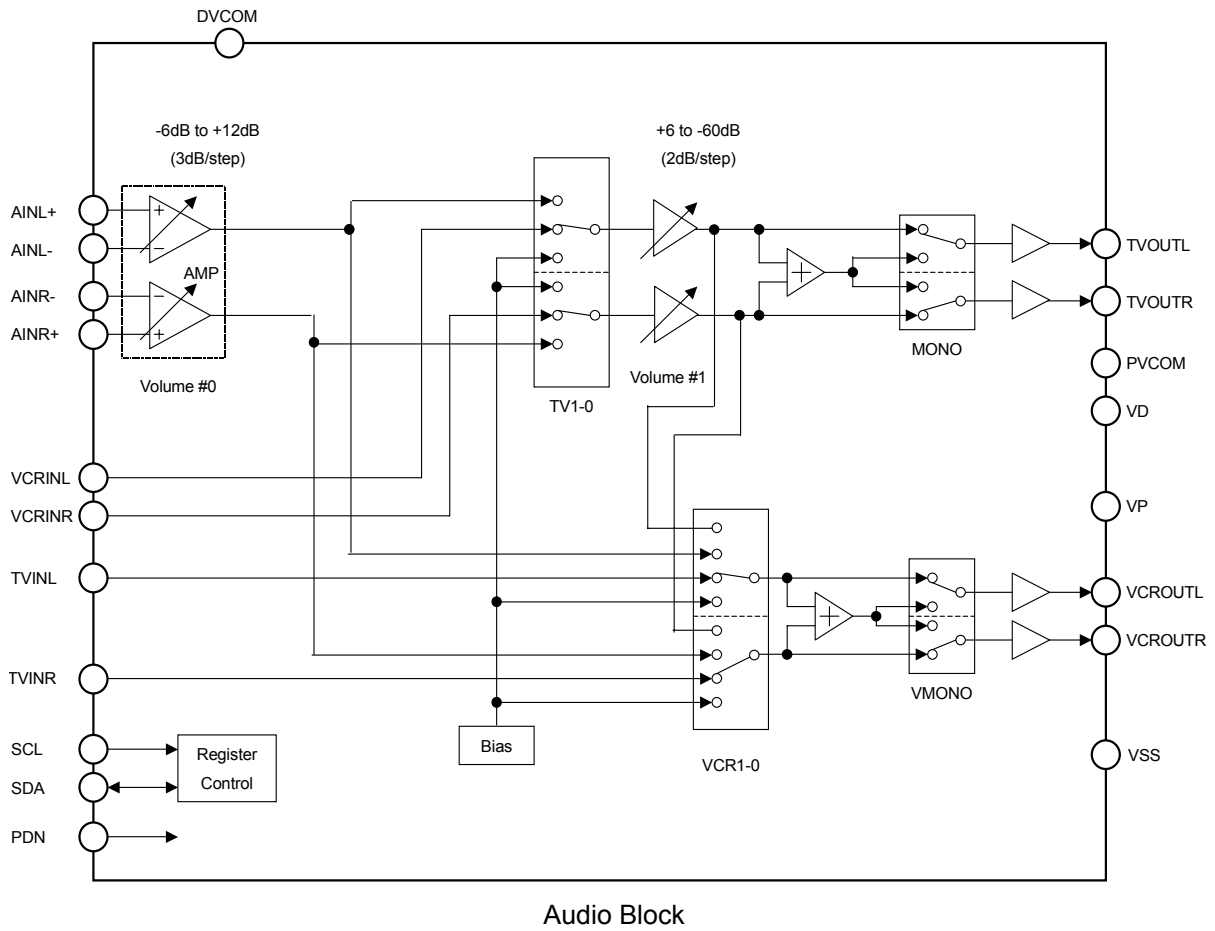

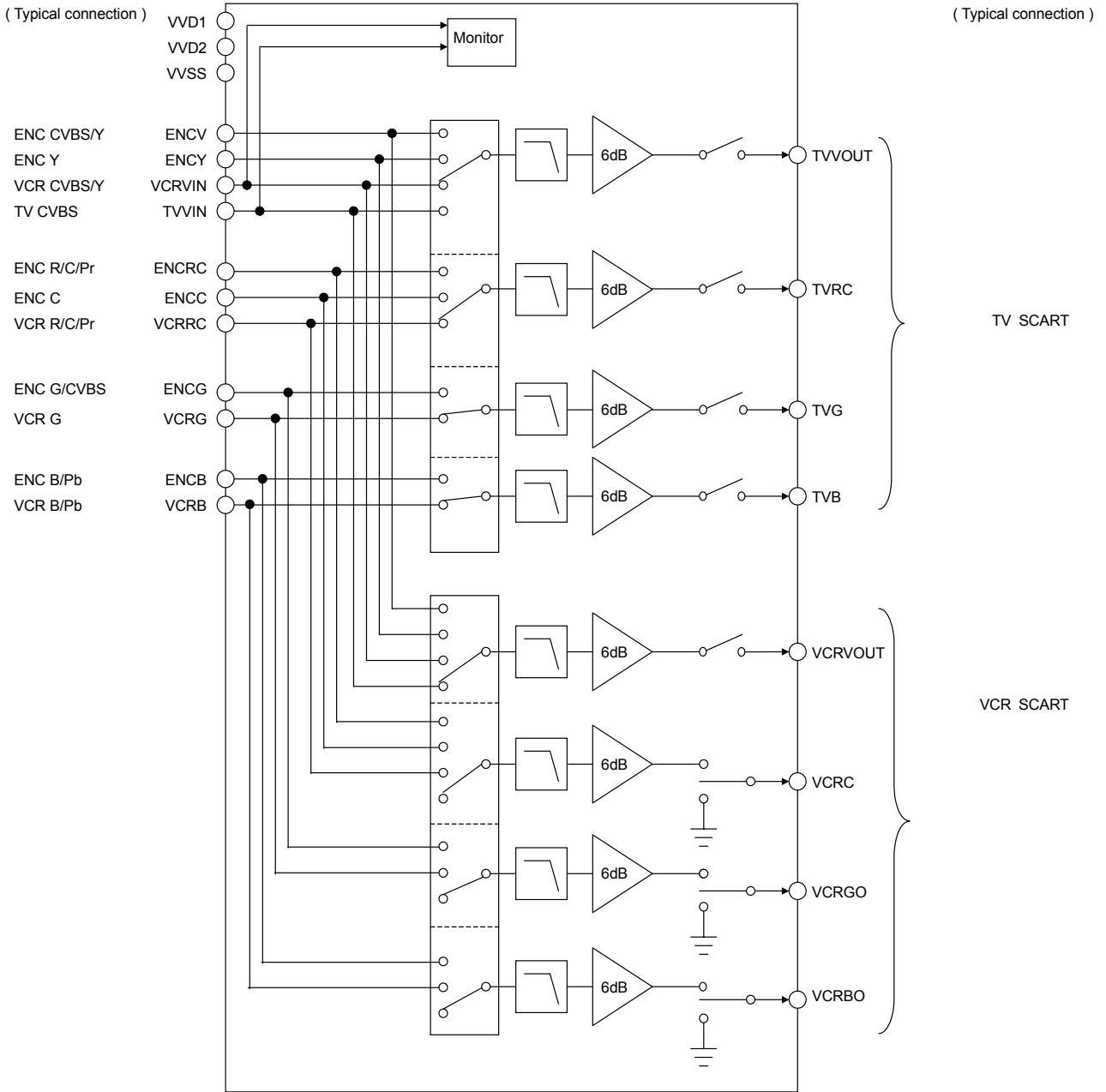

Video Block

(Typical connection)

(Typical connection)

VCR FB

VCRFB

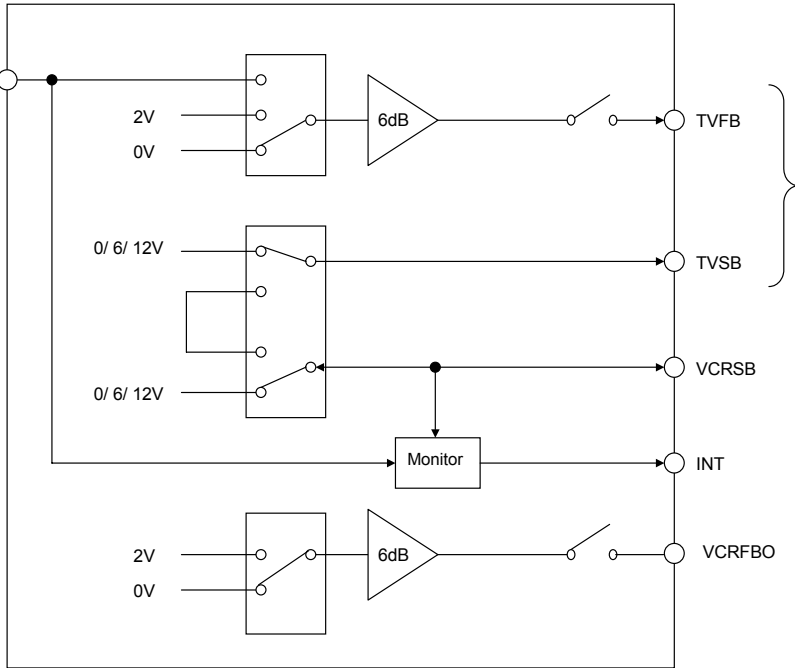

TV SCART

VCR SCART

Video Blanking Block

■ Ordering Guide

AK4708EQ
AKD4708

-10 ~ +70°C 48pin LQFP (0.5mm pitch)
Evaluation board for AK4708

■ Pin Layout

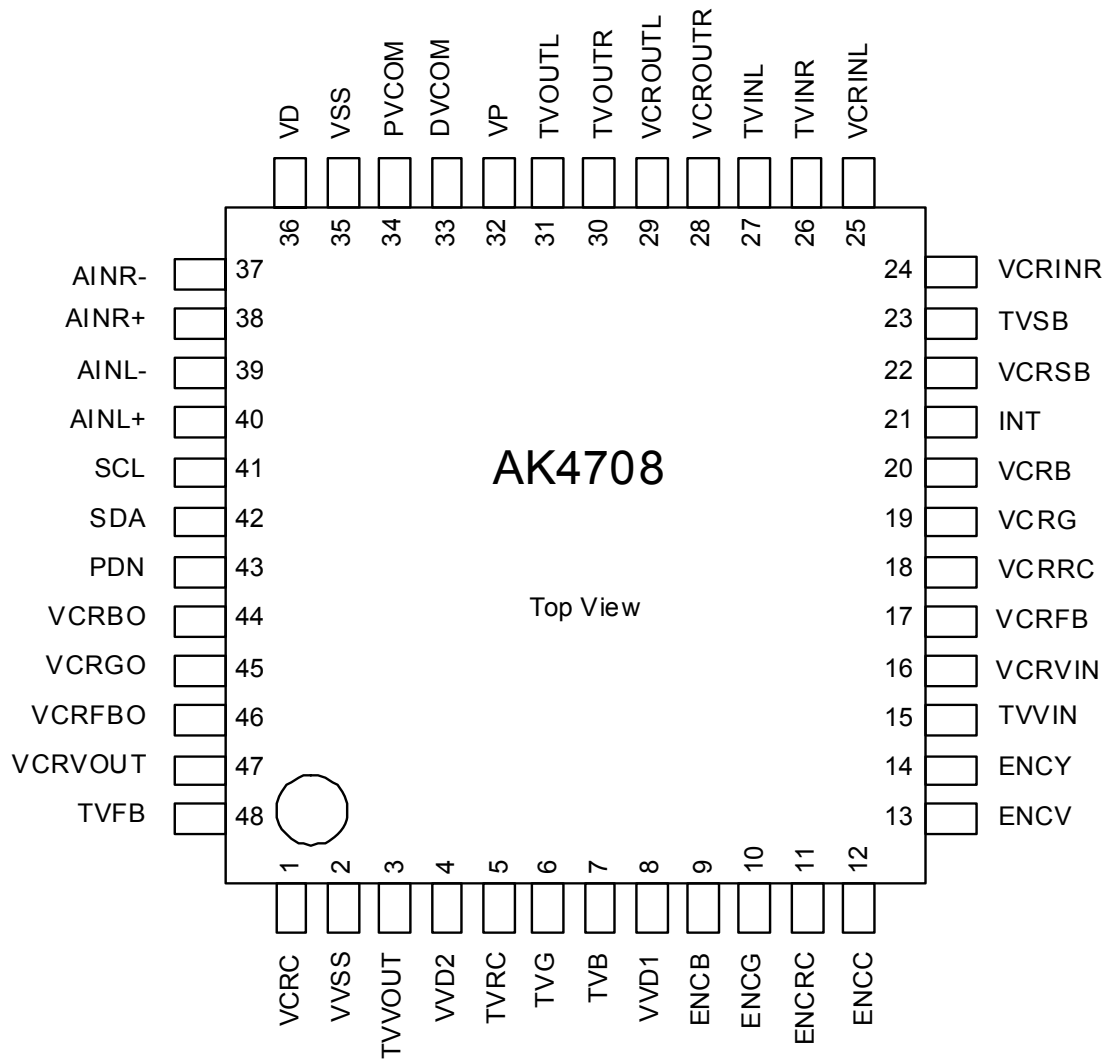

PIN/FUNCTION			
No.	Pin Name	I/O	Function
1	VCRC	O	Chrominance Output Pin for VCR
2	VVSS	-	Video Ground Pin #1, 0V
3	TVVOUT	O	Composite/Luminance Output Pin for TV
4	VVD2	-	Video Power Supply Pin #2, 5V Normally connected to VVSS with a 0.1 μ F ceramic capacitor in parallel with a 10 μ F electrolytic cap.
5	TVRC	O	Red/Chrominance Output Pin for TV
6	TVG	O	Green Output Pin for TV
7	TVB	O	Blue Output Pin for TV
8	VVD1	-	Video Power Supply Pin #1, 5V Normally connected to VVSS with a 0.1 μ F ceramic capacitor in parallel with a 10 μ F electrolytic cap.
9	ENCB	I	Blue Input Pin for Encoder
10	ENCG	I	Green Input Pin for Encoder
11	ENCRC	I	Red/Chrominance Input Pin #1 for Encoder
12	ENCC	I	Chrominance Input Pin #2 for Encoder
13	ENCV	I	Composite/Luminance Input Pin #1 for Encoder
14	ENCY	I	Composite/Luminance Input Pin #2 for Encoder
15	TVVIN	I	Composite/Luminance Input Pin for TV
16	VCRVIN	I	Composite/Luminance Input Pin for VCR
17	VCRFB	I	Fast Blanking Input Pin for VCR
18	VCRRC	I	Red/Chrominance Input Pin for VCR
19	VCRG	I	Green Input Pin for VCR
20	VCRB	I	Blue Input Pin for VCR
21	INT	O	Interrupt Pin for Video Blanking Normally connected to VD(5V) through 10k Ω resistor externally.
22	VCRSB	I/O	Slow Blanking Input/Output Pin for VCR
23	TVSB	O	Slow Blanking Output Pin for TV
24	VCRINR	I	Rch VCR Audio Input Pin
25	VCRINL	I	Lch VCR Audio Input Pin
26	TVINR	I	Rch TV Audio Input Pin
27	TVINL	I	Lch TV Audio Input Pin
28	VCROUTR	O	Rch Analog Output Pin #1
29	VCROUTL	O	Lch Analog Output Pin #1
30	TVOUTR	O	Rch Analog Output Pin #2
31	TVOUTL	O	Lch Analog Output Pin #2
32	VP	-	Power Supply Pin, 12V Normally connected to VSS with a 0.1 μ F ceramic capacitor in parallel with a 10 μ F electrolytic cap.
33	DVCOM	O	Audio Common Voltage Pin #1 Normally connected to VSS with a 0.1 μ F ceramic capacitor in parallel with a 10 μ F electrolytic cap.
34	PVCOM	O	Audio Common Voltage Pin #2 Normally connected to VSS with a 0.1 μ F ceramic capacitor in parallel with a 10 μ F electrolytic cap. The caps affect the settling time of audio bias level.
35	VSS	-	Ground Pin , 0V

PIN/FUNCTION (Continued)

No.	Pin Name	I/O	Function
36	VD	-	Power Supply Pin, 5V Normally connected to VSS with a 0.1 μ F ceramic capacitor in parallel with a 10 μ F electrolytic cap.
37	AINR-	I	Rch Negative Analog Input Pin
38	AINR+	I	Rch Positive Analog Input Pin
39	AINL-	I	Lch Negative Analog Input Pin
40	AINL+	I	Lch Positive Analog Input Pin
41	SCL	I	Control Data Clock Pin
42	SDA	I/O	Control Data Pin
43	PDN	I	Power-Down Mode Pin When at "L", the AK4708 is in the power-down mode and is held in reset. The AK4708 should always be reset upon power-up.
44	VCRBO	O	Blue Output Pin for VCR
45	VCRGO	O	Green Output Pin for VCR
46	VCRFBO	O	Fast Blanking Output Pin for VCR
47	VCRVOUT	O	Composite/Luminance Output Pin for VCR
48	TVFB	O	Fast Blanking Output Pin for TV

Note: All digital input pins should not be left floating.

INTERNAL EQUIVALENT CIRCUIT

Pin No.	Pin Name	Type	Equivalent Circuit	Description
41 43	SCL PDN	Digital IN		
38 37 39 40	AINR+ AINR- AINL- AINL+	Audio IN		
42	SDA	Digital I/O		I2C Bus voltage must not exceed VD.
21	INT	Digital OUT		Normally connected to VD(5V) through 10kΩ resistor externally.
47 48 3 5 6 7 1 44 45 46	VCRVOUT TVFB TVVOUT TVRC TVG TVB VCRC VCRGO VCRBO VCRFBO	Video OUT		

Pin No.	Pin Name	Type	Equivalent Circuit	Description
9 10 11 12 13 14 15 16 17 18 19 20	ENCB ENCG ENCRC ENCC ENCV ENCY TVVIN VCRVIN VCRFB VCRRC VCRG VCRB	Video IN		The 60kΩ is attached for Chrominance input.
22 23	VCRSB TVSB	Video SB		The 120kΩ is not attached for TVSB.
24 25 26 27	VCRINR VCRINL TVINR TVINL	Audio IN		
28 29 30 31	VCROUTR VCROUTL TVOUTR TVOUTL	Audio OUT		
33 34	DVCOM PVCOM	VCOM OUT		

ABSOLUTE MAXIMUM RATINGS

(VSS = VVSS = 0V; Note 1)

Parameter	Symbol	min	max	Units
Power Supply (Note 2)	VD	-0.3	6.0	V
	VVD1	-0.3	6.0	V
	VVD2	-0.3	6.0	V
	VP	-0.3	15	V
Input Current (any pins except for supplies)	IIN	-	±10	mA
Input Voltage	VIND	-0.3	VD+0.3	V
Video Input Voltage	VINV	-0.3	VVD1+0.3	V
Audio Input Voltage (except AINL+/-, AINR+/- pins)	VINA1	-0.3	VP+0.3	V
Audio Input Voltage (AINL+/-, AINR+/- pins)	VINA2	-0.3	VD+0.3	V
Ambient Operating Temperature	Ta	-10	70	°C
Storage Temperature	Tstg	-65	150	°C

Note 1. All voltages with respect to ground.

Note 2. VSS and VVSS must be connected to the same analog ground plane.

WARNING: Operation at or beyond these limits may result in permanent damage to the device.
Normal operation is not guaranteed at these extremes.

RECOMMENDED OPERATING CONDITIONS

(VSS = VVSS = 0V; [Note 1](#))

Parameter	Symbol	min	typ	max	Units
Power Supply (Note 2)	VD	4.75	5.0	5.25	V
	VVD1	4.75	5.0	5.25	V
	VVD2	4.75	5.0	VVD1	V
	VP	10.8	12	13.2	V

Note 1. All voltages with respect to ground.

Note 2. VVD1 and VVD2 must be connected to the same voltage.

*AKM assumes no responsibility for the usage beyond the conditions in this datasheet.

ELECTRICAL CHARACTERISTICS

(Ta = 25°C; VP = 12V, VD = 5V; VVD1 = VVD2 = 5V)

Power Supplies	min	typ	max	Units
Power Supply Current				
Normal Operation (PDN = "H")	(Note 3)		120	mA
VD+VVD1+VVD2				
VP		5	10	mA
Power-Down Mode (PDN = "L")	(Note 4)		100	μA
VD				
VVD1+VVD2				
VP				

Note 3. STBY bit = "0", All video outputs active. No signal, no load for A/V switches.

Note 4. All digital inputs are held at VD or VSS.

DIGITAL CHARACTERISTICS

(Ta = 25°C; VD = 4.75 ~ 5.25V)

Parameter	Symbol	min	typ	max	Units
High-Level Input Voltage	VIH	2.0	-	-	V
Low-Level Input Voltage	VIL	-	-	0.8	V
Low-Level Output Voltage (SDA pin: Iout= 3mA, INT pin: Iout= 1mA)	VOL	-	-	0.4	V
Input Leakage Current (Except VCRSB pin)	Iin	-	-	±10	μA

ANALOG CHARACTERISTICS (AUDIO)

(Ta = 25°C; VP = 12V, VD = 5V; VVD1 = VVD2 = 5V; Signal Frequency = 1kHz;

Measurement frequency = 20Hz ~ 20kHz; RL ≥ 4.5kΩ; 0dB=2Vrms output; unless otherwise specified)

Parameter	min	typ	max	Units
Analog Input: (TVINL/TVINR/VCRINL/VCRINR pins)				
Analog Input Characteristics				
Input Voltage			2.0	Vrms
Input Resistance	100	150	-	kΩ
Analog Input: (AINL+/AINL-/AINR-/AINR+ pins)				
Analog Input Characteristics				
Input Voltage (AIN+) – (AIN–) (Note 6)			2.0	Vrms
Input Resistance (AINL+, AINR+ pins) (Note 7)	140	210		kΩ
Input Resistance (AINL-, AINR- pins) (Note 7)	75	115	-	kΩ
Stereo/Mono Output: (TVOUTL/TVOUTR/VCROUTL/VCROUTR pins) (Note 5)				
Analog Output Characteristics				
Volume#0 Step Width (Note 8)	2.3	3.0	3.7	dB
Volume#1 Step Width (+6dB to –12dB)	1.6	2	2.4	dB
(–12dB to –40dB)	0.5	2	3.5	dB
(–40dB to –60dB)	0.1	2	3.9	dB
THD+N (at 2Vrms output, Note 9)		–86	–80	dB
(at 3Vrms output, Note 9, Note 10)		–60		dB
Dynamic Range (–60dB Output, A-weighted, Note 9)	92	96		dB
S/N (A-weighted, Note 9)	92	96		dB
Interchannel Isolation (Note 9, Note 11)	80	90		dB
Interchannel Gain Mismatch (Note 9, Note 11)	-	0.3	-	dB
Gain Drift	-	200	-	ppm/°C
Load Resistance (AC-Load) TVOUTL/R, VCROUTL/R	4.5			kΩ
Load Capacitance TVOUTL/R, VCROUTL/R			20	pF
Output Voltage (Note 13)	1.85	2	2.15	Vrms
Power Supply Rejection (PSR) (Note 12)	-	50		dB

Note 5. Measured by Audio Precision System Two Cascade.

Note 6. If input is single ended, maximum input voltage is 1Vrms.

Note 7. Differential signal is input to AIN- and AIN+. volume #0 = 0dB.

Note 8. The output level of the internal AMP with volume #0 should be less than 2Vrms..

The output level must be adjusted by the volume #1 when output level of the AK4708 exceeds 2Vrms.

Note 9. Analog In to TVOUT. Path : AINL+/- → TVOUTL, AINR+/- → TVOUTR

Note 10. Except VCROUTL/VCROUTR pins.

Note 11. Between TVOUTL and TVOUTR with analog inputs AINL+/-, AINL/R+/-, 1kHz/0dB.

Note 12. The PSR is applied to VD with 1kHz, 100mV.

Note 13. The audio output must not exceed 3Vrms at VP±5%. The audio output must not exceed 2.15Vrms at VP±10%.

ANALOG CHARACTERISTICS (VIDEO)

($T_a = 25^\circ\text{C}$; $V_P = 12\text{V}$, $V_D = 5\text{V}$; $V_{VD1} = V_{VD2} = 5\text{V}$; unless otherwise specified.)

Parameter	Conditions	min	typ	max	Units
Sync Tip Clamp Voltage	at output pin.		0.7		V
R/G/B Clamp Voltage	at output pin.		0.7		V
Pb/Pr Clamp Voltage	at output pin.		2.2		V
Chrominance Bias Voltage	at output pin.		2.2		V
Gain	Input = 0.3Vp-p, 100kHz	5.5	6	6.5	dB
Interchannel Gain Mismatch1	TVRC, TVG, TVB. Input = 0.3Vp-p, 100kHz.	-0.5	-	0.5	dB
Interchannel Gain Mismatch2	VCRC, VCRGO, VCRBO. Input = 0.3Vp-p, 100kHz.	-0.5	-	0.5	dB
Frequency Response	Input=0.3Vp-p, $C_1=C_2=0\text{pF}$. 100kHz to 6MHz. at 10MHz. at 27MHz.	-1.0		0.5	dB
			-3		dB
			-40	-25	dB
Group Delay Distortion	At 4.43MHz with respect to 1MHz.			15	ns
Input Impedance	Chrominance input (internally biased)	40	60	-	k Ω
Input Signal	f = 100kHz, maximum with distortion < 1.0%, gain = 6dB.	-	-	1.5	Vpp
Load Resistance	(Figure 1)	150	-	-	Ω
Load Capacitance	C1 (Figure 1)			400	pF
	C2 (Figure 1)			15	pF
Dynamic Output Signal	f = 100kHz, maximum with distortion < 1.0%	-	-	3	Vpp
Y/C Crosstalk	f = 4.43MHz, 1Vp-p input. Among TVVOUT, TVRC and VCRVOUT outputs.	-	-50	-	dB
S/N	Reference Level = 0.7Vp-p, CCIR 567 weighting. BW = 15kHz to 5MHz.	-	74	-	dB
Differential Gain	0.7Vpp 5steps modulated staircase. chrominance & burst are 280mVpp, 4.43MHz.	-	0.6	-	%
Differential Phase	0.7Vpp 5steps modulated staircase. chrominance & burst are 280mVpp, 4.43MHz.	-	0.8	-	Degree

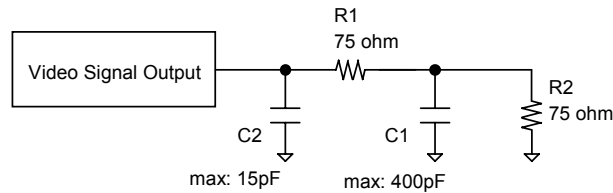

Figure 1. Load Resistance R_1+R_2 and Load Capacitance C_1/C_2 .

SWITCHING CHARACTERISTICS

(Ta = 25°C; VP = 10.8 ~ 13.2V, VD = 4.75 ~ 5.25V, VVD1 = VVD2 = 4.75 ~ 5.25V)

Parameter	Symbol	min	typ	max	Units
Control Interface Timing (I²C Bus):					
SCL Clock Frequency	fSCL	-		400	kHz
Bus Free Time Between Transmissions	tBUF	1.3		-	μs
Start Condition Hold Time (prior to first clock pulse)	tHD:STA	0.6		-	μs
Clock Low Time	tLOW	1.3		-	μs
Clock High Time	tHIGH	0.6		-	μs
Setup Time for Repeated Start Condition	tSU:STA	0.6		-	μs
SDA Hold Time from SCL Falling (Note 14)	tHD:DAT	0		-	μs
SDA Setup Time from SCL Rising	tSU:DAT	0.1		-	μs
Rise Time of Both SDA and SCL Lines	tR	-		0.3	μs
Fall Time of Both SDA and SCL Lines	tF	-		0.3	μs
Setup Time for Stop Condition	tSU:STO	0.6		-	μs
Pulse Width of Spike Noise Suppressed by Input Filter	tSP	0		50	ns
Capacitive load on bus	Cb			400	pF
Reset Timing					
PDN Pulse Width (Note 15)	tPD	150			ns

Note 14. Data must be held for sufficient time to bridge the 300 ns transition time of SCL.

Note 15. The AK4708 should be reset by PDN pin = "L" upon power up.

Note 16. I²C is a registered trademark of Philips Semiconductors.

■ Timing Diagram

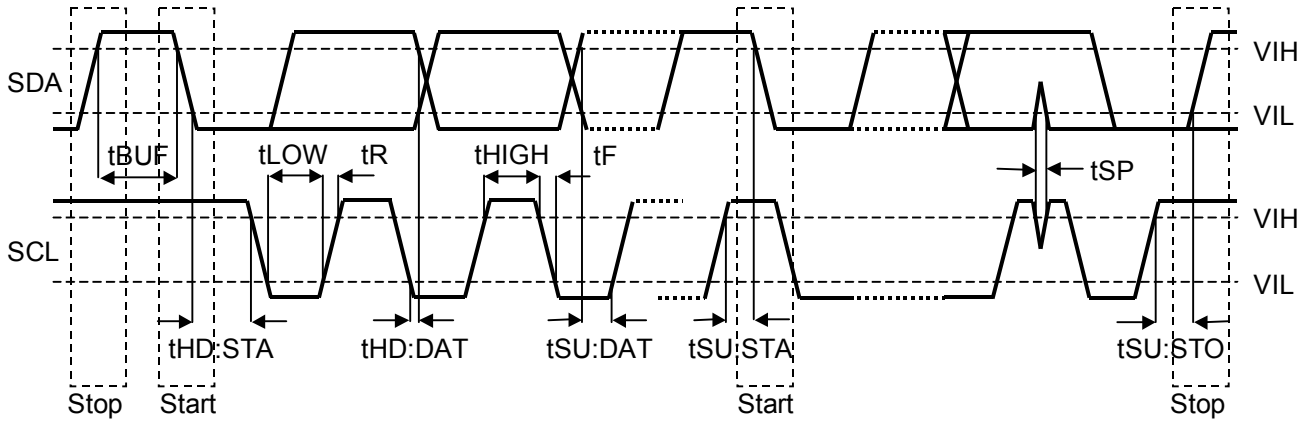

Figure 2. I²C Bus mode Timing

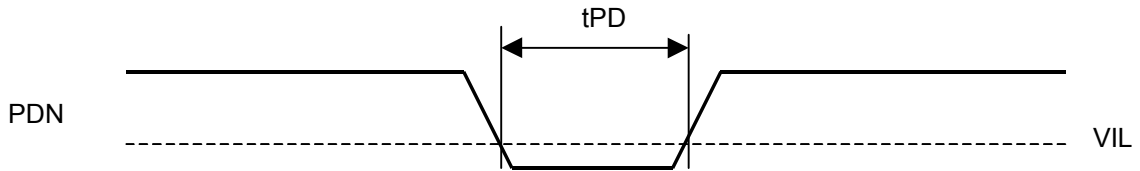

Figure 3. Power-down Timing

OPERATION OVERVIEW

1. System Reset and Power-down options

The AK4708 should be reset once by bringing PDN pin = “L” upon power-up. The AK4708 has several operation modes. The PDN pin, AUTO bit, BIAS bit, STBY bit and AMP bit control operation modes as shown in [Table 1](#) and [Table 2](#).

Mode	PDN pin	AUTO bit	STBY bit	BIAS bit	Mode
0	“L”	x	x	x	Full Power-down
1	“H”	1	x	x	Auto Startup mode (Power-on default)
2	“H”	0	1	1	Standby & Mute
3	“H”	0	1	0	Standby
4	“H”	0	0	1	Mute (AMP power down)
5	“H”	0	0	0	Normal operation (AMP operation)

Table 1. Operation Mode Settings (x: Don't Care)

Mode		Register Control	Audio Bias Level	Video Output	TVFB TVSB VCRFBO	VCRSB
0	Full Power-down	NOT available	Power down	Hi-Z	Hi-Z	Pull -down (Note 17)
1	Auto Startup mode (Power-on default)	Available				
	Video input (Note 18)		Active	Active (Note 25)		
2	Standby & mute		Power down	Hi-Z/ Active	Active	Active
3	Standby		Active			
4	Mute (AMP power down)		Power down			
5	Normal operation (AMP operation)	Active (Note 19)				

Note 17. Internally pulled down by 120kΩ (typ) resistor.

Note 18. Video input to TVVIN or VCRVIN.

Note 19. TVOUTL/R are muted by Mute bit in the default state.

Note 20. VCRC, VCRGO, VCRBO output 0V for termination.

Table 2. Status of each operation modes

■ System Reset and Full Power-down Mode

The AK4708 should be reset once by bringing PDN pin = “L” upon power-up.

PDN pin: Power down pin

L: Device power down & reset

H: Normal operation.

■ Auto Startup Mode

After when the PDN pin is set to “H”, the AK4708 is in the auto startup mode. In this mode, all blocks except for the video detection circuit are powered down. Once the video detection circuit detects video signal from TVVIN pin or VCRVIN pin, the AK4708 goes to the stand-by mode automatically and sends “H” pulse via INT pin. The sources of TVOUTL/R are fixed to VCRINL/R, the sources of VCROUTL/R are fixed to TVINL/R respectively. The source of DC- restore circuit is VCRVIN pin. To exit the auto startup mode, set the AUTO bit to “0”.

AUTO bit (00H D3): Auto startup bit

0: Auto startup disable. (Manual startup)

1: Auto startup enable. (default)

■ Bias Mode

When the BIAS bit = “1”, the bias voltage on the audio output goes to GND level. Bringing BIAS bit to “0” changes this bias voltage smoothly from GND to VP/2 by 2sec (typ.). This removes the huge click noise related the sudden change of bias voltage at power-on. The change of BIAS bit from “1” to “0” also makes smooth transient from VP/2 to GND by 2sec (typ.). This removes the huge click noise related the sudden change of bias voltage at power-off.

BIAS bit (00H D1): Bias-off bit

0: Normal operation.

1: Set the audio bias to GND. (default)

■ Standby Mode

When the AUTO bit = BIAS bit = “0” and the STBY bit = “1”, the AK4708 is forced into TV-VCR loop through mode. In this mode, the sources of TVOUTL/R pins are fixed to VCRINL/R pins; the sources of VCROUTL/R are fixed to TVINL/R pins respectively. All register values themselves are NOT changed by STBY bit = “1”.

STBY bit (00H D0): Standby bit

0: Normal operation.

1: Standby mode. (default)

■ Normal Operation Mode

To change analog switches, set the AUTO bit, BIAS bit and STBY bit to “0”. The AK4708 is in power-down mode until PDN pin = “H”. The Figure 4 shows an example of the system timing at the power-down and power-up by PDN pin.

■ Typical Operation Sequence (auto setup mode)

The Figure 4 shows an example of the system timing at auto startup mode.

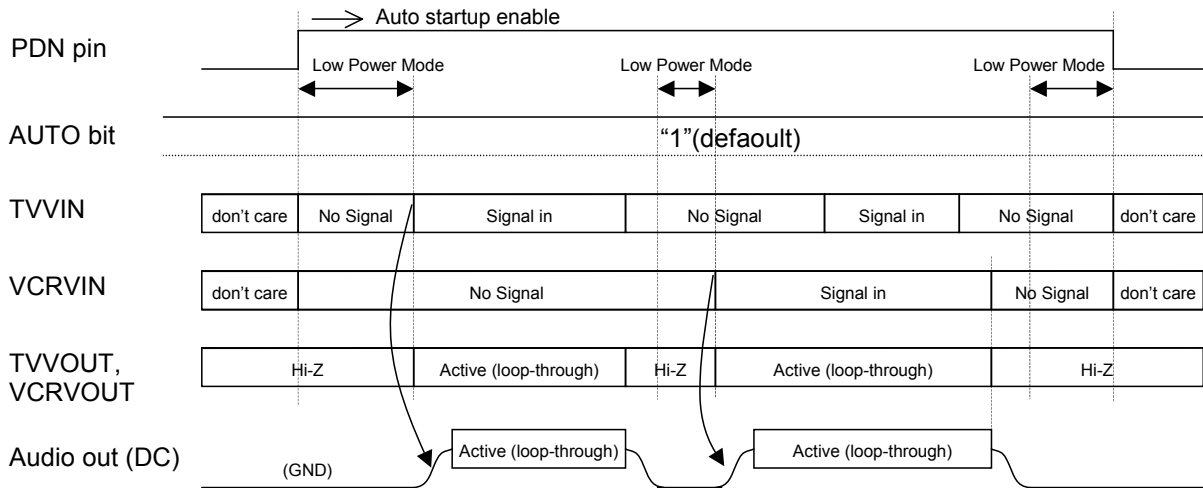
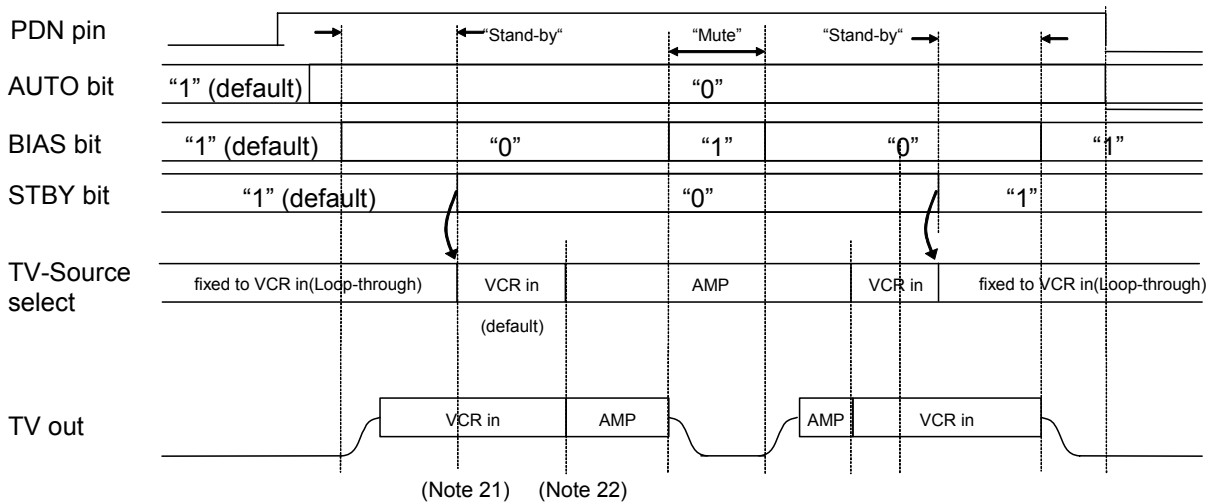

Figure 4. Auto startup mode sequence

■ Typical Operation Sequence (except auto setup mode)

Figure 5 shows an example of the system timing at normal operation mode.



Note 21. Set the STBY bit = “0” to pass for 20.2ms after set the VMUTE bit = “0”, to prevent the click noise.

Note 22. Mute the analog outputs externally if click noise affects the system.

Figure 5. Typical operating sequence

2. Audio Block

■ Switch Control

The AK4708 has switch matrixes designed primarily for SCART routing. Those are controlled via the control register as shown in Table 3 and Table 4 (Please refer to the Block Diagram).

(01H: D1-D0)

TV1	TV0	Source of TVOUTL/R
0	0	AMP
0	1	VCRIN
1	0	Mute
1	1	(Reserved)

(default)

Table 3. TVOUT Switch Configuration

(01H: D5-D4)

VCR1	VCR0	Source of VCROUTL/R
0	0	AMP
0	1	TVIN
1	0	Mute
1	1	Volume#1 output

(default)

Table 4. VCROUT Switch Configuration

■ Volume Control #0 (7-Level Volume)

The AK4708 has a 7-level volume control (Volume #0) as shown in Table 5. The volume reflects the change of register value immediately.

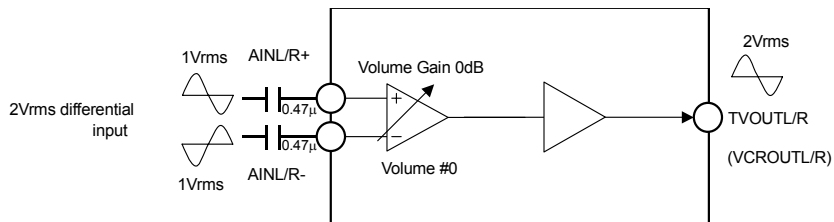

Figure 6. Volume #0(Volume Gain=0dB:default), Full Differential Stereo Input

(0DH: D5-D3)

VOL2	VOL1	VOL0	Volume #0 Gain	Output Level (Typ)
1	1	1	+12dB	2Vrms (with 0.5Vrms differential input)
1	1	0	+9dB	-
1	0	1	+6dB	2Vrms (with 1Vrms differential input)
1	0	0	+3dB	-
0	1	1	0dB	2Vrms (with 2Vrms differential input)
0	1	0	-3dB	-
0	0	1	-6dB	1Vrms (with 2Vrms differential input)
0	0	0	Mute	-

(default)

Note: Volume #1=0dB

Table 5. Volume #0, Full Differential Stereo Input

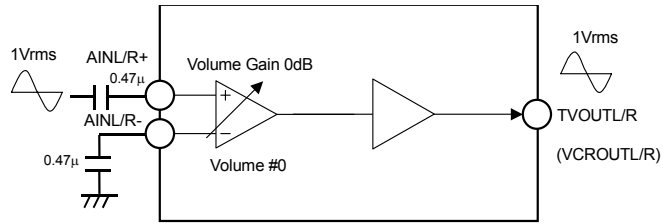

Figure 7. Volume #0(Volume Gain=0dB:default), Single-ended Input

(0DH: D5-D3)

VOL2	VOL1	VOL0	Volume #0 Gain	Output Level (Typ)
1	1	1	+12dB	2Vrms (with 0.5Vrms input)
1	1	0	+9dB	-
1	0	1	+6dB	2Vrms (with 1Vrms input)
1	0	0	+3dB	-
0	1	1	0dB	1Vrms (with 1Vrms input)
0	1	0	-3dB	-
0	0	1	-6dB	0.5Vrms (with 1Vrms input)
0	0	0	Mute	-

(default)

Note: Volume #1=0dB

Table 6. Volume #0, Single-ended Input

■ Volume Control #1 (Main Volume)

The AK4708 has main volume control (Volume #1) as shown in Table 7.

(02H: D5-D0)

L5	L4	L3	L2	L1	L0	Gain
1	0	0	0	1	0	+6dB
1	0	0	0	0	1	+4dB
1	0	0	0	0	0	+2dB
0	1	1	1	1	1	0dB
...
0	0	0	0	0	1	-60dB
0	0	0	0	0	0	Mute

(default)

Note: The output must not exceed 3Vrms.

Table 7. Volume #1

When the MOD bit = “1”(default), changing levels don’t have pop noise. MDT1-0 bits select the transition time (Table 8). When the new gain value 1EH(-2dB) is written to gain resistor while the actual (stable) gain is 1FH(0dB), the gain changes to 1EH(-2dB) within the transition time selected by MDT1-0 bits. The AK4708 compares the actual gain to the value of gain register after finishing the transition time, and re-changes the actual gain to new resistor value within the transition time if the register value is different from the actual gain when compared. When the MOD bit = “0” then there is no transition time and the gain changes immediately. This change may cause a click noise.

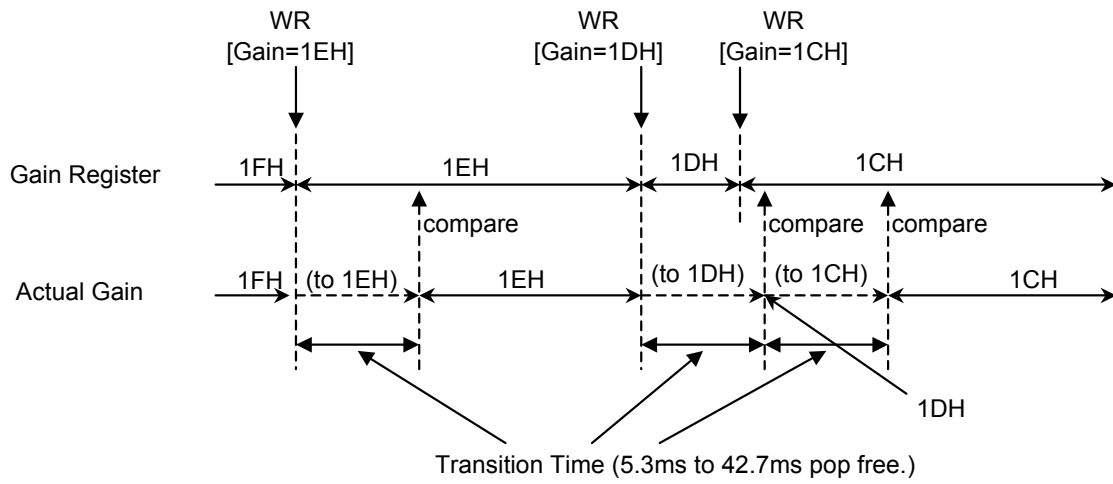

Figure 8. Volume Change Operation (MOD bit = "1")

MDT1	MDT0	Transition Time
0	0	5.3ms
0	1	10.7ms
1	0	21.3ms
1	1	42.7ms

(default)

Table 8. Volume Transition Time (typ.)

3. Video Block

■ Video Switch Control

The AK4708 has switches for TV and VCR. Each switch can be controlled via registers independently. When AUTO bit = "1" or STBY bit = "1", these switches setting is ignored and set to fixed configuration (loop-through mode). Please refer the auto startup mode and standby mode.

(04H: D2-D0)

Mode	VTV2-0 bit	Source of TVVOUT pin	Source of TVRC pin	Source of TVG pin	Source of TVB pin
Shutdown	000	(Hi-Z)	(Hi-Z)	(Hi-Z)	(Hi-Z)
Encoder CVBS+RGB or Encoder YPbPr	001	ENCV pin (Encoder CVBS or Y)	ENCRC pin (Encoder Red,C or Pb)	ENCG pin (Encoder Green or Y)	ENCB pin (Encoder Blue or Pr)
Encoder Y/C 1	010	ENCV pin (Encoder Y)	ENCRC pin (Encoder C)	(Hi-Z)	(Hi-Z)
Encoder Y/C 2	011	ENCY pin (Encoder Y)	ENCC pin (Encoder C)	(Hi-Z)	(Hi-Z)
VCR (default)	100	VCRVIN pin (VCR CVBS or Y)	VCRRC pin (VCR Red,C or Pb)	VCRG pin (VCR Green or Y)	VCRB pin (VCR Blue or Pr)
TV CVBS	101	TVVIN pin (TV CVBS)	(Hi-Z)	(Hi-Z)	(Hi-Z)
(Reserved)	110	-	-	-	-
(Reserved)	111	-	-	-	-

Table 9. TV video output (Note 23)

(04H: D5-D3)

Mode	VVCR2-0 bit	Source of VCRVOUT pin	Source of VCRC pin	Source of VCRGO pin	Source of VCRBO pin
Shutdown	000	(Hi-Z)	(Hi-Z)	(Hi-Z)	(Hi-Z)
Encoder CVBS or Y/C 1	001	ENCV pin (Encoder CVBS or Y)	ENCRC pin (Encoder C)	(Hi-Z)	(Hi-Z)
Encoder CVBS or Y/C 2	010	ENCY pin (Encoder CVBS or Y)	ENCC pin (Encoder C)	(Hi-Z)	(Hi-Z)
TV CVBS (default)	011	TVVIN pin (TV CVBS)	(Hi-Z)	(Hi-Z)	(Hi-Z)
VCR	100	VCRVIN pin (VCR CVBS)	VCRRC pin (VCR Red, C)	VCRG pin (VCR Green)	VCRB pin (VCR Blue)
Encoder CVBS /RGB	101	ENCV pin (Encoder CVBS or Y)	ENCRC pin (Encoder Red,C or Pb)	ENCG pin (Encoder Green or Y)	ENCB pin (Encoder Blue or Pr)
(Reserved)	110	-	-	-	-
(Reserved)	111	-	-	-	-

Table 10. VCR video output (Note 23)

Note 23. When input the video signal via ENCRC pin or VCRRC pin, set CLAMP1-0 bits respectively.

■ Video Output Control (05H: D6-D0, 0CH:D2-D0)

Each video output can be set to Hi-Z individually via control registers. These settings are ignored when the AUTO bit = "1".

- TVV: TVVOUT output control
- TVR: TVRCOUT output control
- TVG: TVGOUT output control
- TVB: TVBOUT output control
- VCRV: VCRVOUT output control
- VCRC: VCRC output control
- VCRG: VCRGO output control
- VCRB: VCRBO output control
- TVFB: TVFB output control
- VCRFB: VCRFBO output control
- 0: Hi-Z. (default)
- 1: Active.

■ RGB/Chroma Bi-directional Control for VCR SCART (05H: D7, D5)

The AK4708 supports the bi-directional RGB/Chroma signal on the VCR SCART.

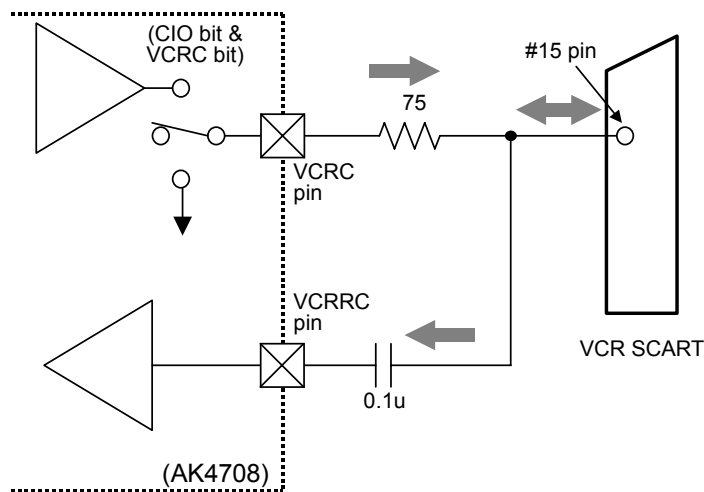

Figure 9. VCR Red/Chroma Bi-directional Control

CIO	VCRC	State of VCRC pin
0	0	Hi-z
0	1	Active
1	0	Connected to GND
1	1	Connected to GND

(default)

Table 11 VCR Red/Chroma Bi-directional Control

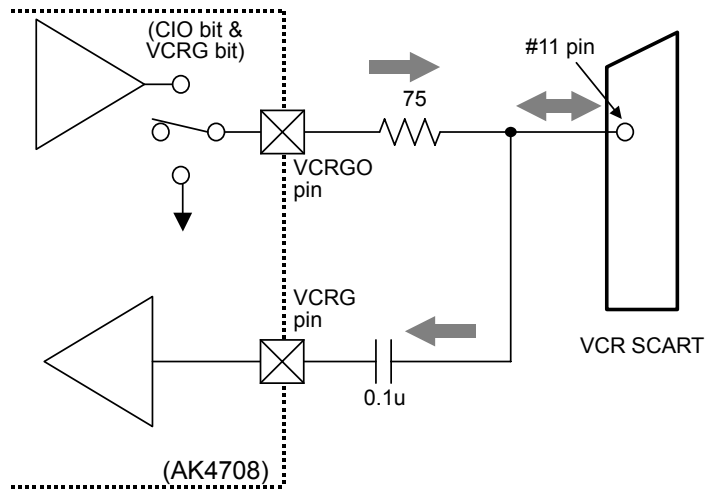

Figure 10. VCR Green Bi-directional Control

CIO	VCRG	State of VCRGO pin
0	0	Hi-z
0	1	Active
1	0	Connected to GND
1	1	Connected to GND

(default)

Table 12 VCR Green Bi-directional Control

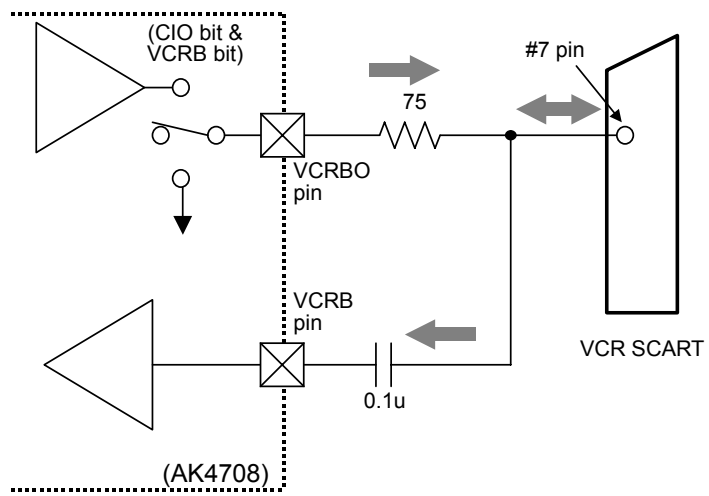

Figure 11. VCR Blue Bi-directional Control

CIO	VCRB	State of VCRC pin
0	0	Hi-z
0	1	Active
1	0	Connected to GND
1	1	Connected to GND

(default)

Table 13 VCR Blue Bi-directional Control

■ Clamp and DC-restore circuit control (06H: D7-D2)

Each CVBS and Y input has the sync tip clamp circuit. The DC-restore circuit has two clamp voltages 0.7V(typ) and 2.2V(typ) to support both RGB and YPbPr signal. They correspond to 0.35V(typ) and 1.1V(typ) at the SCART connector when matched by 75Ω resistors. The CLAMP1, CLAMP0 and CLAMPB bits select the input circuit for ENCRG pin (Encoder Red/Chroma), ENCB pin (Encoder Blue), VCRRC pin (VCR Red/Chroma) and VCRB pin (VCR Blue) respectively. VCLP2-0 bits select the sync source of DC- restore circuit.

CLAMPB	CLAMP0	VCRRC Input Circuit	VCRB Input Circuit	note
0	0	DC restore clamp active (0.7V at sync timing/output pin)	DC restore clamp active (0.7V at sync timing/output pin)	for RGB
0	1	Biased (2.2V at sync timing/output pin)	(DC restore clamp active) (0.7V at sync timing output pin)	for Y/C
1	0	DC restore clamp active (2.2V at sync timing/output pin)	DC restore clamp active (2.2V at sync timing/output pin)	for Y/Pb/Pr
1	1	(reserved)	(reserved)	

Table 14. DC-restore control for VCR Input

CLAMPB	CLAMP1	ENCRG Input Circuit	ENCB Input Circuit	note
0	0	DC restore clamp active (0.7V at sync timing/output pin)	DC restore clamp active (0.7V at sync timing/output pin)	for RGB
0	1	Biased (2.2V at sync timing/output pin)	DC restore clamp active (0.7V at sync timing output pin)	for Y/C
1	0	DC restore clamp active (2.2V at sync timing/output pin)	DC restore clamp active (2.2V at sync timing/output pin)	for Y/Pb/Pr
1	1	(reserved)	(reserved)	

Table 15. DC-restore control for Encoder Input

CLAMP2	ENCG Input Circuit	note
0	DC restore clamp active (0.7V at sync timing/output pin)	for RGB
1	Sync tip clamp active (0.7V at sync timing/output pin)	for Y/Pb/Pr

Note: When the VTV2-0 bits = "001"(source for TV = Encoder CVBS /RGB), TVG bit = "1" (TVG = active) and VCLP1-0 bits = "11"(DC restore source = ENCG), the sync tip is selected even if the CLAMP2 bit = "0".

Table 16. DC-restore control for Encoder Green/Y Input

VCLP2-0: DC restore source control

VCLP2	VCLP1	VCLP0	Sync Source of DC Restore
0	0	0	ENCV
0	0	1	ENCY
0	1	0	VCRVIN
0	1	1	ENCG
1	0	0	VCRG
1	0	1	(reserved)
1	1	0	(reserved)
1	1	1	(reserved)

Note: When the AUTO bit = "1", the source is fixed to VCRVIN.

Table 17. DC-restore source control

4. Blanking Control

The AK4708 supports Fast Blanking signals and Slow Blanking (Function Switching) signals for TV/VCR SCART.

■ Input/Output Control for Fast/Slow Blanking

FB1-0: TV Fast Blanking output control (07H: D1-D0)

FB1 bit	FB0 bit	TVFB pin Output Level	
0	0	0V	(default)
0	1	2V<, 4V(typ) at 150Ω load	
1	0	Same as VCR FB input (4V/0V)	
1	1	(Reserved)	

Table 18. TV Fast Blanking output (Note: minimum load is 150Ω)

SBT1-0: TV Slow Blanking output control (07H: D3-D2)

SBT1 bit	SBT0 bit	TVSB pin Output Level	
0	0	< 2V	(default)
0	1	5V <, < 7V	
1	0	(Reserved)	
1	1	10V <	

Table 19. TV Slow Blanking output (Note: minimum load is 10kΩ)

FBV: VCR Fast Blanking output control (0CH: D7)

FBV bit	VCRFBO pin Output Level	
0	0V	(default)
1	2V<, 4V(typ) at 150Ω load	

Table 20. VCR Fast Blanking output (Note: minimum load is 150Ω)

SBV1-0: VCR Slow Blanking output control (07H: D5-D4)

SBV1 bit	SBV0 bit	VCRSB pin Output Level	
0	0	< 2V	(default)
0	1	5V <, < 7V	
1	0	(Reserved)	
1	1	10V <	

Table 21. VCR Slow Blanking output (Note: minimum load is 10kΩ)

SBIO1-0: TV/VCR Slow Blanking I/O control (07H: D7-D6)

SBIO1 bit	SBIO0 bit	VCRSB pin Direction	TVSB pin Direction	
0	0	Output (Controlled by SBV1-0 bits)	Output (Controlled by SBT1-0 bits)	(default)
0	1	(Reserved)	(Reserved)	
1	0	Input (Stored in SVCRI-0 bits)	Output (Controlled by SBT1-0 bits)	
1	1	Input (Stored in SVCRI-0 bits)	Output (Same output as VCR SB)	

Table 22. TV/VCR Slow Blanking I/O control

■ VCR Fast Blanking for VCR SCART (0CH: D7, D2)

The AK4708 supports the bi-directional VCR Fast Blanking signal on the VCR SCART.

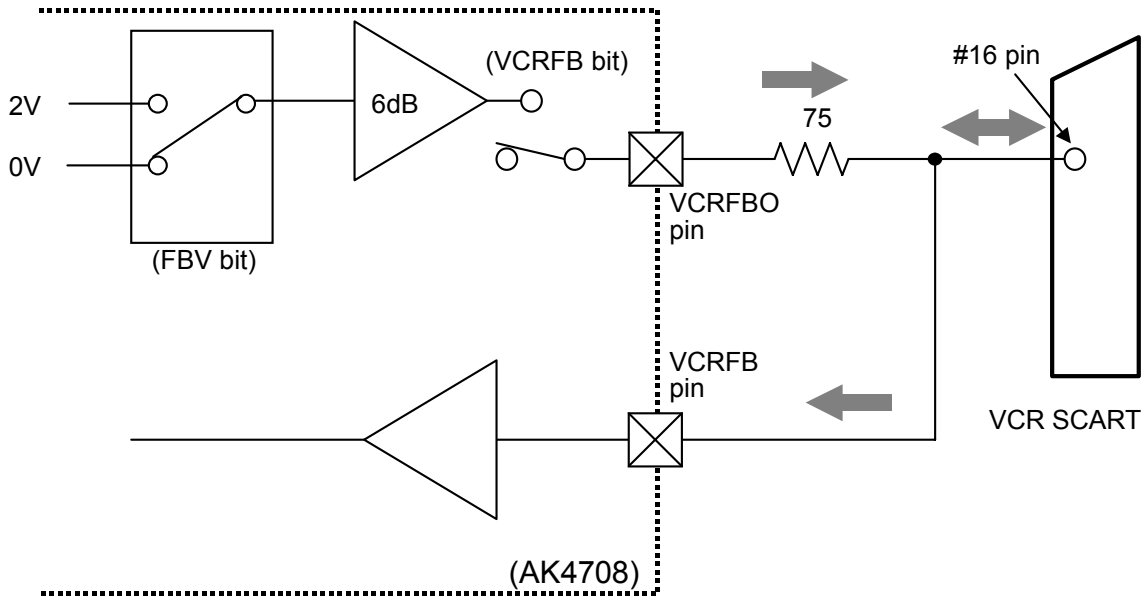

Figure 12. VCR Fast Blanking Bi-directional Control

FBV	VCRFB	State of VCRFBO pin
0	0	Hi-Z
0	1	Active / 0V(typ)
1	0	Hi-Z
1	1	Active / 2V<, 4V(typ) at 150Ω load

(default)

Table 23 VCR Fast Blanking Bi-directional Control

5. Monitor Options and INT function

■ Monitor Options (08H: D4-D0)

The AK4708 has several detection functions. SVCR1-0 bits, FVCR bit, VCMON bit and TVMON bit reflect the input DC level of VCR slow blanking, the input DC level of VCR fast blanking and signals input to TVVIN or VCRVIN pins.

SVCR1-0: VCR Slow blanking status monitor

SVCR1-0 bits reflect the voltage at VCRSB pin only when the VCRSB is in the input mode.
When the VCRSB is in the output mode, SVCR1-0 bits hold previous value.

VCRSB pin input level	SVCR1 bit	SVCR0 bit
< 2V	0	0
4.5 to 7V	0	1
(Reserved)	1	0
9.5 <	1	1

Table 24. VCR Slow Blanking monitor

FVCR: VCR Fast blanking input level monitor

This bit is enabled when TVFB bit = "1".

VCRFB pin input level	FVCR bit
< 0.4V	0
1V <	1

Table 25. VCR Fast Blanking monitor (Typical threshold is 0.7V)

VCMON: VCRVIN pin video input monitor (MCOMN bit = "1"),

TVVIN pin or VCRVIN pin video input monitor (MCOMN bit = "0")

0: No video signal detected.

1: Detects video signal.

TVMON: TVVIN pin video input monitor (active when MCOMN bit = "1")

0: No video signal detected.

1: Detects video signal.

AUTO (00H D3)	MCOMN (09H D7)	TVVIN signal	VCRVIN signal	TVMON (08H D4)	VCMON (08H D3)
0	0	0	0	0	0
0	0	0	1	0	1
0	0	1	0	0	1
0	0	1	1	0	1
0	1	0	0	0	0
0	1	0	1	0	1
0	1	1	0	1	0
0	1	1	1	1	1
1	x	0	0	0	0
1	x	0	1	0	1
1	x	1	0	0	1
1	x	1	1	0	1

(x: don't care)

Note 24. TVVIN/VCRVIN signal: signal 0 = No signal applied, signal 1 = signal applied

Table 26. TV/VCR Monitor Function

■ INT Function and Mask Options (09H: D3-D1)

Changes of the 08H status can be monitored via the INT pin. The INT pin is the open drain output and goes “L” for 2μs (typ.) when the status of 08H is changed. This pin should be connected to VD (typ. 5V) through 10kΩ resistor or lower voltage through 10kΩ resistor. MTV bit, MVC bit, MCOMN bit, MFVCR bit and MSVCR bit control the reflection of the status change of these monitors onto the INT pin from report to prevent to masks each monitor.

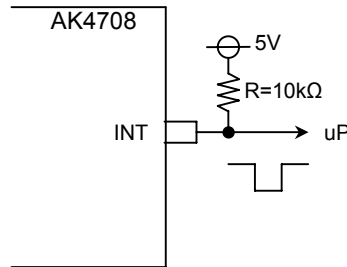

Figure 13. INT pin

MVC: VCMON Mask. Refer [Table 28](#).

MTV: TVMON Mask. Refer [Table 27](#).

MCOMN: Refer [Table 26](#)

AUTO (00H D3)	TVMON (08H D4)	MTV (09H D4)	INT
0	No Change	0	Hi-Z
0	No Change	1	Hi-Z
0	Change	0	Generates “L” Pulse
0	Change	1	Hi-Z
1	No Change	0	Hi-Z
1	No Change	1	Hi-Z

Note 25. When the STBY bit = “0”, the TV Monitor Mask function is enabled.

Note 26. When AUTO bit = “1”, TVMON does not change

Table 27. TV Monitor Mask

AUTO (00H D3)	VCMON (08H D3)	MVC (09H D3)	INT
0	No Change	0	Hi-Z
0	No Change	1	Hi-Z
0	Change	0	Generates “L” Pulse
0	Change	1	Hi-Z
1	No Change	0	Hi-Z
1	No Change	1	Hi-Z
1	Change	0	Generates “L” Pulse
1	Change	1	Generates “L” Pulse

Note 27. When the STBY bit = “0”, the VCR Monitor Mask function is enabled.

Table 28. VCR Monitor Mask

MFVCR: FVCR Monitor mask.

0: Change of FVCR is reflected to INT pin. (default)

1: Change of FVCR is NOT reflected to INT pin.

MSVCR: SVCR1-0 Monitor mask

0: Change of SVCR1-0 is reflected to INT pin. (default)

1: Change of SVCR1-0 is NOT reflected to INT pin.

6. Control Interface

I²C-bus Control Mode

1. WRITE Operations

Figure 14 shows the data transfer sequence in I²C-bus mode. All commands are preceded by a START condition. A HIGH to LOW transition on the SDA line while SCL is HIGH indicates a START condition (Figure 20). After the START condition, a slave address is sent. This address is 7bits long followed by the eighth bit that is a data direction bit (R/W). The most significant seven bits of the slave address are fixed as “0010001”. If the slave address match that of the AK4708, the AK4708 generates the acknowledge and the operation is executed. The master must generate the acknowledge-related clock pulse and release the SDA line (HIGH) during the acknowledge clock pulse (Figure 22). A “1” for R/W bit indicates that the read operation is to be executed. A “0” indicates that the write operation is to be executed. The second byte consists of the address for control registers of the AK4708. The format is MSB first, and those most significant 3-bits are fixed to zeros (Figure 16). The data after the second byte contain control data. The format is MSB first, 8bits (Figure 17). The AK4708 generates an acknowledge after each byte has been received. A data transfer is always terminated by a STOP condition generated by the master. A LOW to HIGH transition on the SDA line while SCL is HIGH defines a STOP condition (Figure 20).

The AK4708 can execute multiple one byte write operations in a sequence. After receipt of the third byte, the AK4708 generates an acknowledge, and awaits the next data again. The master can transmit more than one byte instead of terminating the write cycle after the first data byte is transferred. After the receipt of each data, the internal address counter is incremented by one, and the next data is taken into next address automatically. If the address exceeds 0DH prior to generating the stop condition, the address counter will “roll over” to 00H and the previous data will be overwritten. The data on the SDA line must be stable during the HIGH period of the clock. The HIGH or LOW state of the data line can only change when the clock signal on the SCL line is LOW (Figure 22) except for the START and the STOP condition.

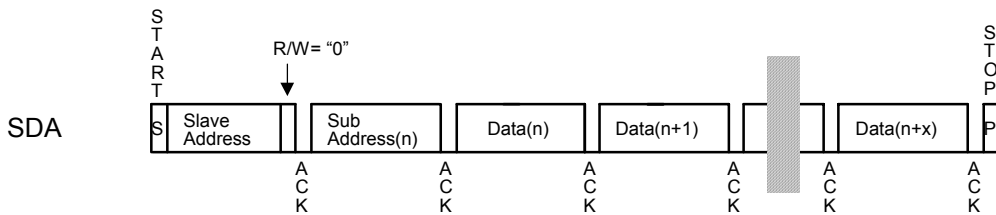

Figure 14. Data transfer sequence at the I²C-bus mode

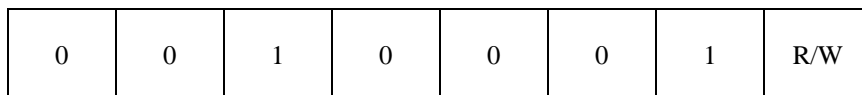

Figure 15. The first byte

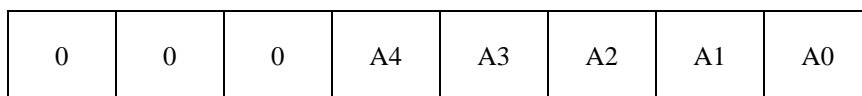

Figure 16. The second byte

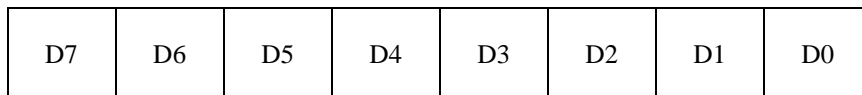

Figure 17. Byte structure after the second byte

2. READ Operations

Set R/W bit = "1" for READ operations. After transmission of data, the master can read the next address's data by generating an acknowledge instead of terminating the write cycle after the receipt the first data word. After the receipt of each data, the internal address counter is incremented by one, and the next data is taken into next address automatically. If the address exceeds 09H prior to generating the stop condition, the address counter will "roll over" to 00H and the previous data will be overwritten.

The AK4708 supports two basic read operations: CURRENT ADDRESS READ and RANDOM READ.

2-1. CURRENT ADDRESS READ

The AK4708 contains an internal address counter that maintains the address of the last word accessed, incremented by one. Therefore, if the last access (either a read or write) was to address n, the next CURRENT READ operation would access data from the address n+1. After receipt of the slave address with R/W bit set to "1", the AK4708 generates an acknowledge, transmits 1byte data which address is set by the internal address counter and increments the internal address counter by 1. If the master does not generate an acknowledge to the data but generate the stop condition, the AK4708 discontinues transmission.

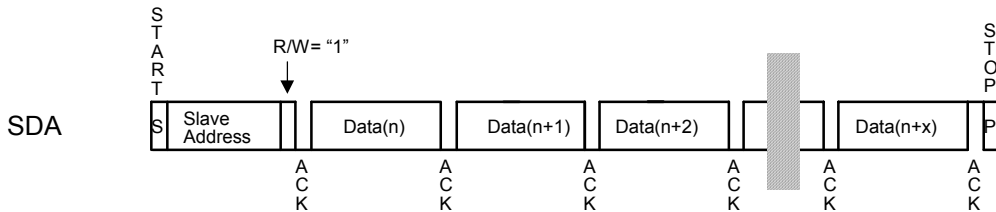

Figure 18. CURRENT ADDRESS READ

2-2. RANDOM READ

Random read operation allows the master to access any memory location at random. Prior to issuing the slave address with the R/W bit set to "1", the master must first perform a "dummy" write operation. The master issues a start condition, slave address (R/W bit = "0") and then the register address to read. After the register address is acknowledge, the master immediately reissues the start condition and the slave address with the R/W bit set to "1". Then the AK4708 generates an acknowledge, 1-byte data and increments the internal address counter by 1. If the master does not generate an acknowledge to the data but generate the stop condition, the AK4708 discontinues transmission.

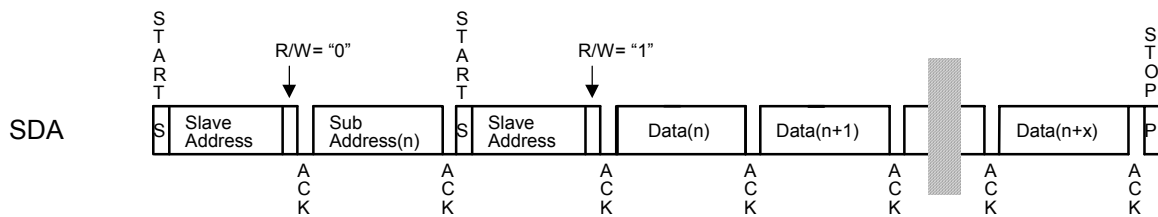

Figure 19. RANDOM ADDRESS READ

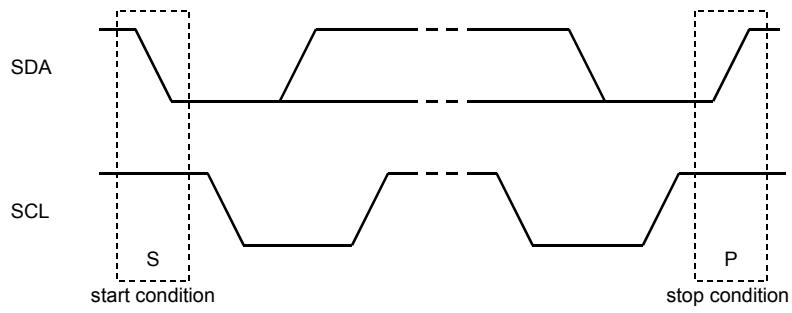

Figure 20. START and STOP conditions

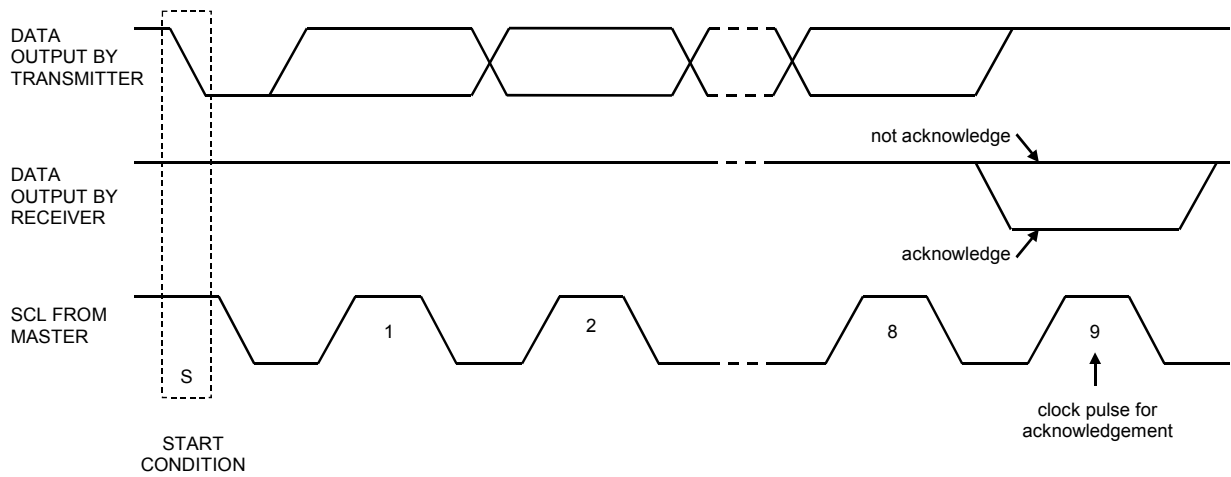

Figure 21. Acknowledge on the I²C-bus

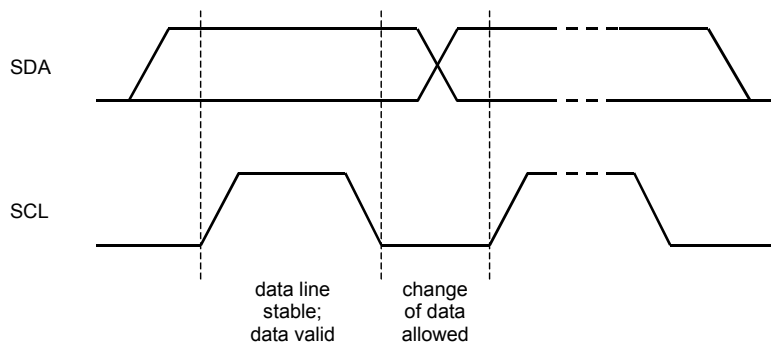

Figure 22. Bit transfer on the I²C-bus

■ Register Map

Addr	Register Name	D7	D6	D5	D4	D3	D2	D1	D0
00H	Control	0	0	0	0	AUTO	0	BIAS	STBY
01H	Switch	VMUTE	0	VCR1	VCR0	MONO	1	TV1	TV0
02H	Main Volume	0	0	L5	L4	L3	L2	L1	L0
03H	Zerocross	0	VMONO	1	0	0	MOD	MDT1	MDT0
04H	Video switch	0	0	VVCR2	VVCR1	VVCR0	VTV2	VTV1	VTV0
05H	Video output enable	CIO	TVFB	VCRC	VCRV	TVB	TVG	TVR	TVV
06H	Video volume/clamp	CLAMPB	VCLP1	VCLP0	CLAMP2	CLAMP1	CLAMP0	0	0
07H	S/F Blanking control	SBIO1	SBIO0	SBV1	SBV0	SBT1	SBT0	FB1	FB0
08H	S/F Blanking monitor	0	0	FVCR1	TVMON	VCMON	FVCR0	SVCR1	SVCR0
09H	Monitor mask	MCOMN	0	0	MTV	MVC	MFVCR	MSVCR	0
0AH	DC restore	0	0	0	0	VCLP2	0	1	1
0BH	Reserve	0	0	0	0	0	0	0	0
0CH	VCR output	FVB	0	0	0	0	VCRFB	VCRB	VCRG
0DH	Volume	0	0	VOL2	VOL1	VOL0	1	1	1

When the PDN pin goes “L”, the registers are initialized to their default values.

While the PDN pin = “H”, all registers can be accessed.

Do not write any data to the register over 0DH.

■ Register Definitions

Addr	Register Name	D7	D6	D5	D4	D3	D2	D1	D0
00H	Control	0	0	0	0	AUTO	0	BIAS	STBY
	R/W	R/W							
	Default	0	0	0	0	1	0	1	1

STBY: Standby control

0: Normal Operation

1: Standby Mode (default). All registers are not initialized.

AMP: Powered down and timings are reset.

Source of TVOUT: fixed to VCRIN.

Source of VCROUT: fixed to TVIN.

Source of MONOOUT: fixed to VCRIN.

Source of TVVOUT: fixed to VCRVIN (or Hi-Z).

Source of TVRC: fixed to VCRRC (or Hi-Z).

Source of TVG: fixed to VCRG (or Hi-Z).

Source of TVB: fixed to VCRB (or Hi-Z).

Source of VCRVOUT: fixed to TVVIN (or Hi-Z).

Source of VCRC: fixed to Hi-Z.

Source of VCRGO: fixed to Hi-Z.

Source of VCRBO: fixed to Hi-Z.

BIAS: Audio output control

0: Normal operation

1: ALL Audio outputs to GND (default)

AUTO: Auto startup bit

0: Auto startup disable (Manual startup).

1: Auto startup enable (default).

Note: When the SBIO1 bit = “1”(default = “0”), the change of AUTO bit may cause a “L” pulse on INT pin.

Addr	Register Name	D7	D6	D5	D4	D3	D2	D1	D0
01H	Switch	VMUTE	0	VCR1	VCR0	MONO	1	TV1	TV0
	R/W	R/W							
	Default	1	0	0	1	0	1	0	1

TV1-0: TVOUTL/R pins source switch

- 00: AMP
- 01: VCRINL/R pins (default)
- 10: MUTE
- 11: Reserved

MONO: Mono select for TVOUTL/R pins

- 0: Stereo. (default)
- 1: Mono. (L+R)/2

VCR1-0: VCROUTL/R pins source switch

- 00: AMP
- 01: TVINL/R pins (default)
- 10: MUTE
- 11: Volume#1 output

VMUTE: Mute switch for volume #1

- 0: Normal operation
- 1: Mute the volume #1 (default)

Addr	Register Name	D7	D6	D5	D4	D3	D2	D1	D0
02H	Main volume	0	0	L5	L4	L3	L2	L1	L0
	R/W	R/W							
	Default	0	0	0	1	1	1	1	1

L5-0: Volume #1 control

Those registers control both Lch and Rch of Volume #1.

- 111111 to
- 100011: (Reserved)
- 100010: Volume gain = +6dB
- 100001: Volume gain = +4dB
- 100000: Volume gain = +2dB
- 011111: Volume gain = +0dB (default)
- 011110: Volume gain = -2dB
- ...
- 000011: Volume gain = -56dB
- 000010: Volume gain = -58dB
- 000001: Volume gain = -60dB
- 000000: Volume gain = Mute

Addr	Register Name	D7	D6	D5	D4	D3	D2	D1	D0
03H	Volume Control	0	VMONO	1	0	0	MOD	MDT1	MDT0
	R/W	R/W							
	Default	0	0	1	0	0	1	1	1

MDT1-0: The time length control of volume transition time

- 00: typ. 5.3 ms
- 01: typ. 10.7 ms
- 10: typ. 21.3 ms
- 11: typ. 42.7 ms (default)

MOD: Soft transition enable for volume #1 control

- 0: Disable
The volume value changes immediately without soft transition.
- 1: Enable (default)
The volume value changes with soft transition.
This function is disabled when STBY bit = "1".

VMONO: Mono select for VCROUTL/R pins

- 0: Stereo. (default)
- 1: Mono. (L+R)/2

Addr	Register Name	D7	D6	D5	D4	D3	D2	D1	D0
04H	Video switch	0	0	VVCR2	VVCR1	VVCR0	VTV2	VTV1	VTV0
	R/W	R/W							
	Default	0	0	0	1	1	1	0	0

VTV2-0: Selector for TV video output

Refer [Table 9](#).

VVCR2-0: Selector for VCR video output

Refer [Table 10](#).

Addr	Register Name	D7	D6	D5	D4	D3	D2	D1	D0
05H	Output Enable	CIO	TVFB	VCRC	VCRV	TVB	TVG	TVR	TVV
	R/W	R/W							
	Default	0	0	0	0	0	0	0	0

TVV: TVVOUT output control

TVR: TVRCOUT output control

TVG: TVGOUT output control

TVB: TVBOUT output control

VCRV: VCRVOUT output control

VCRC: VCRC output control

TVFB: TVFB output control

0: Hi-Z (default)

1: Active.

CIO: VCR RGB I/O control for VCR SCART

Refer [Table 11](#), [Table 12](#) and [Table 13](#).

Addr	Register Name	D7	D6	D5	D4	D3	D2	D1	D0
06H	Video volume	CLAMPB	VCLP1	VCLP0	CLAMP2	CLAMP1	CLAMP0	0	0
	R/W	R/W							
	Default	0	0	0	0	0	1	0	0

CLAMPB, CLAMP2-0: Clamp control.

Refer [Table 14](#), [Table 15](#) and [Table 16](#).

VCLP1-0: DC restore source control

00: ENCV pin (default)

01: ENCY pin

10: VCRVIN pin

11: (Reserved)

When the AUTO bit = "1", the source is fixed to VCRVIN pin.

Addr	Register Name	D7	D6	D5	D4	D3	D2	D1	D0
07H	S/F Blanking	SBIO1	SBIO0	SBV1	SBV0	SBT1	SBT0	FB1	FB0
	R/W	R/W							
	Default	0	0	0	0	0	0	0	0

FB1-0: TV Fast Blanking output control (for TVFB pin)

00: 0V (default)

01: 2V<, 4V(typ) at 150Ω load

10: follow VCR FB input (4V/0V)

11: (Reserved)

SBT1-0: TV Slow Blanking output control (for TVSB pin. minimum load is 10kΩ.)

00: < 2V (default)

01: 5V <, < 7V

10: (Reserved)

11: 10V <

SBV1-0: VCR Slow Blanking output control (for VCRSB pin. minimum load is 10kΩ.)

00: < 2V (default)

01: 5V <, < 7V

10: (Reserved)

11: 10V <

SBIO1-0: TV/VCR Slow Blanking I/O control

Refer [Table 22](#).

Addr	Register Name	D7	D6	D5	D4	D3	D2	D1	D0
08H	Monitor	0	0	FVCR1	TVMON	VCMON	FVCR0	SVCR1	SVCR0
	R/W	READ							
	Default	0	0	0	0	0	0	0	0

SVCR1-0, FVCR1-0: VCR fast blanking/slow blanking monitor

Refer [Table 24](#), [Table 25](#).

VCMON, TVMON: VCR/TV video input monitor

Refer [Table 26](#).

Addr	Register Name	D7	D6	D5	D4	D3	D2	D1	D0
09H	Monitor mask	MCOMN	0	0	MTV	MVC	MFVCR	MSVCR	0
	R/W	R/W							
	Default	0	0	0	0	1	0	0	0

MSVCR: SVCR1-0 bits Monitor mask

- 0: The INT pin reflects the change of SVCR1-0 bit. (default)
- 1: The INT pin does not reflect the change of SVCR1-0 bits.

MFVCR: FVCR Monitor mask

- 0: The INT pin reflects the change of MFVCR bit. (default)
- 1: The INT pin does not reflect the change of MFVCR bit.

MVC: VCR input monitor mask

Refer [Table 28](#).

MTV: TV input monitor mask

Refer [Table 27](#).

MCOMN: Monitor mask option

Refer [Table 26](#).

Addr	Register Name	D7	D6	D5	D4	D3	D2	D1	D0
0AH	DC restore	0	0	0	0	VCLP2	0	1	1
	R/W	R/W							
	Default	0	0	0	0	0	0	1	1

VCLP2: DC restore source control

Refer [Table 17](#)

Addr	Register Name	D7	D6	D5	D4	D3	D2	D1	D0
0CH	VCR output	FBV	0	0	0	0	VCRFB	VCRB	VCRG
	R/W	R/W							
	Default	0	0	0	0	0	0	0	0

VCRG: VCRGO output control

VCRB: VCRBO output control

VCRFB: VCRFBO output control

- 0: Hi-Z (default)
- 1: Active.

FBV: VCR Fast Blanking output control (for VCRFBO pin)

- 0: 0V (default)
- 1: 2V<, 4V(typ) at 150Ω load

Addr	Register Name	D7	D6	D5	D4	D3	D2	D1	D0
0DH	Main volume	0	0	VOL2	VOL1	VOL0	1	1	1
	R/W	R/W							
	Default	0	0	0	1	1	1	1	1

VOL2-0: Volume #0 control

Those registers control both Lch and Rch of Volume #0.

111: Volume gain = +12dB

110: Volume gain = +9dB

101: Volume gain = +6dB

100: Volume gain = +3dB

011: Volume gain = +0dB (default)

010: Volume gain = -3dB

001: Volume gain = -6dB

000: MUTE

SYSTEM DESIGN

Figure 23 shows the system connection diagram example. The evaluation board AKD4708 demonstrates application circuits, the optimum layout, power supply arrangements and measurement results.

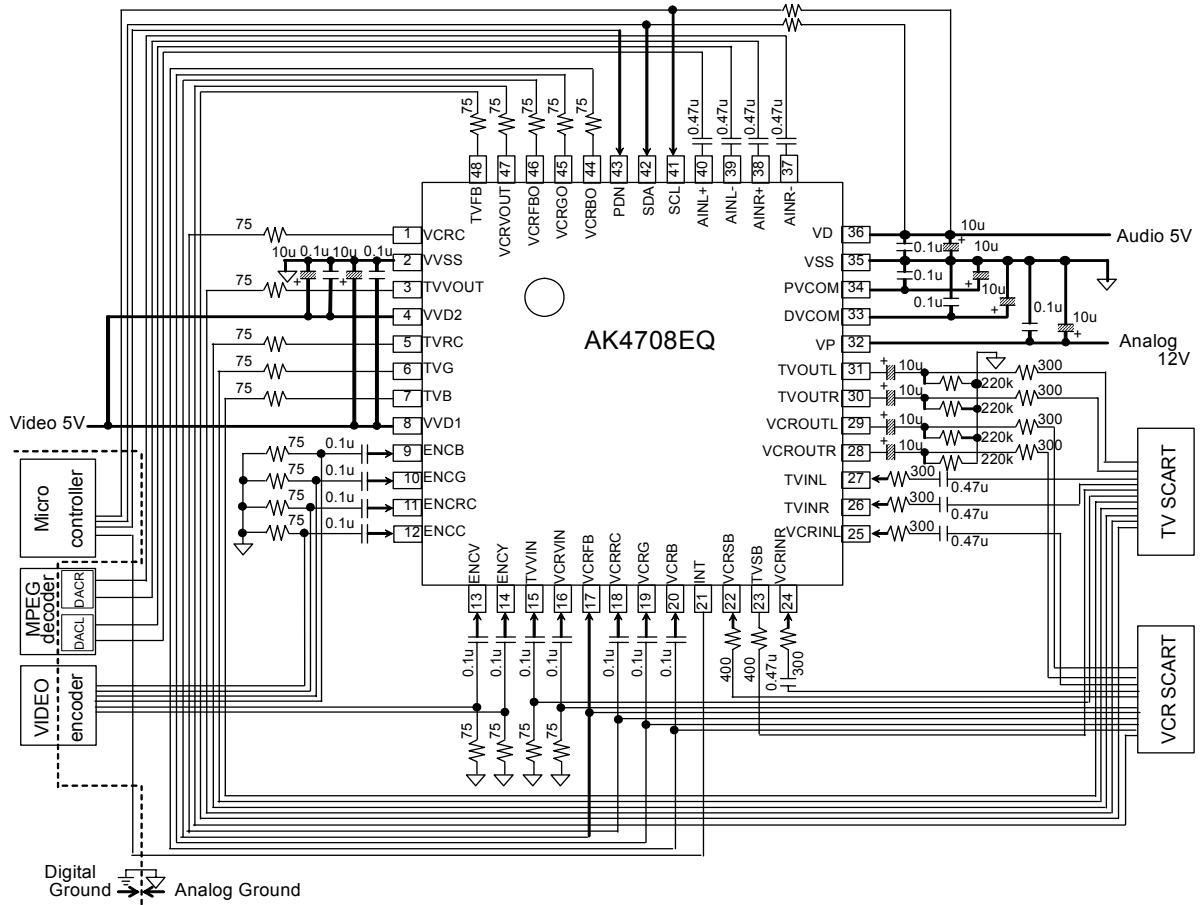

Figure 23. Typical Connection Diagram

■ Grounding and Power Supply Decoupling

VD, VP, VVD1, VVD2, VSS and VVSS should be supplied from analog supply unit with low impedance and be separated from system digital supply. An electrolytic capacitor 10 μ F parallel with a 0.1 μ F ceramic capacitor should be attached to these pins to eliminate the effects of high frequency noise. The 0.1 μ F ceramic capacitor should be placed as near to VD (VP, VVD1, VVD2) as possible.

■ Voltage Reference

Each DVCOM/PVCOM are common voltage of this chip. An electrolytic capacitor 10 μ F parallel with a 0.1 μ F ceramic capacitor should be attached to these VCOM pins to eliminate the effects of high frequency noise. No load current should be drawn from these VCOM pins. All signals, especially clocks, should be kept away from these VCOM pins in order to avoid unwanted coupling into the AK4708.

■ Analog Audio Outputs

The analog outputs are also single-ended and centered on 5.6V(typ.). The output signal range is typically 2Vrms .

■ External Circuit Example

Analog Audio Input pin

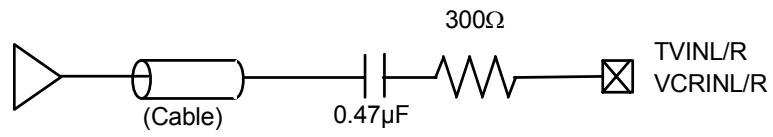

Analog Audio Input pin

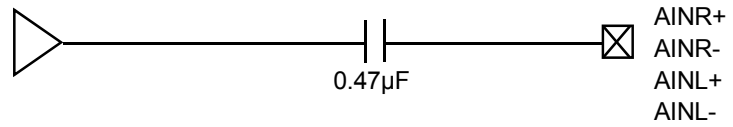

Analog Audio Output pin

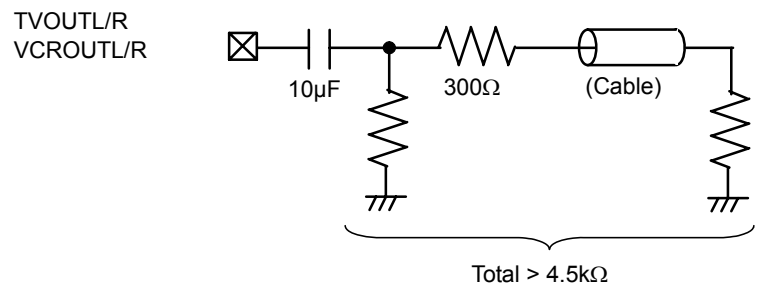

Analog Video Input pin

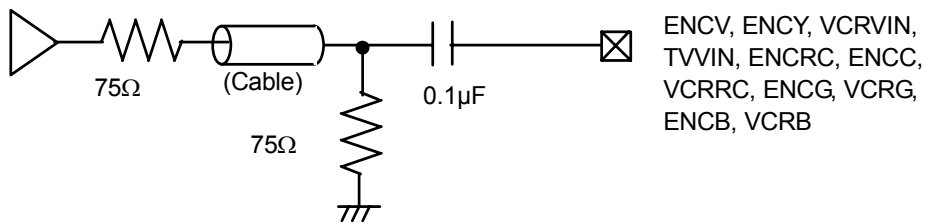

Analog Video Output pin

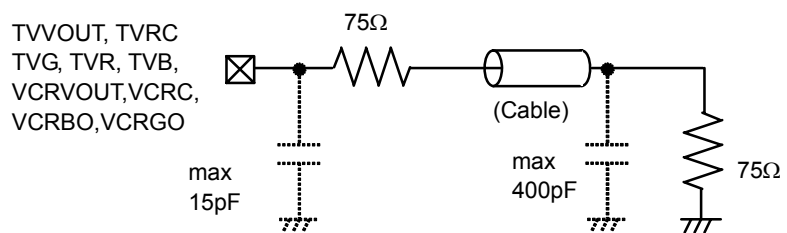

Slow Blanking pin

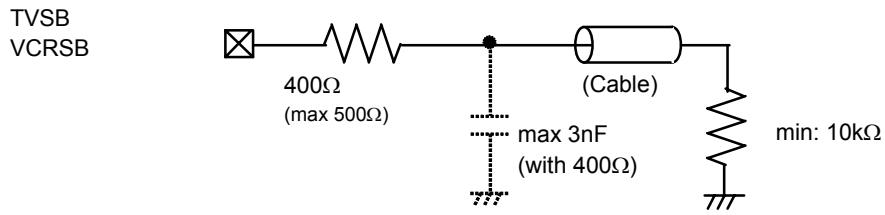

Fast Blanking Input pin

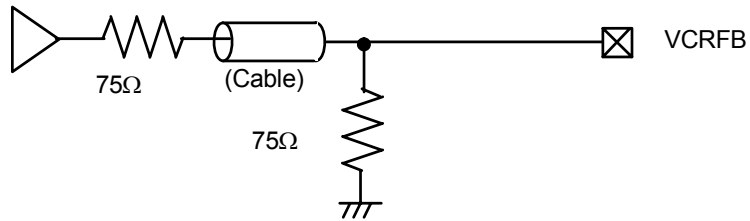

Fast Blanking Output pin

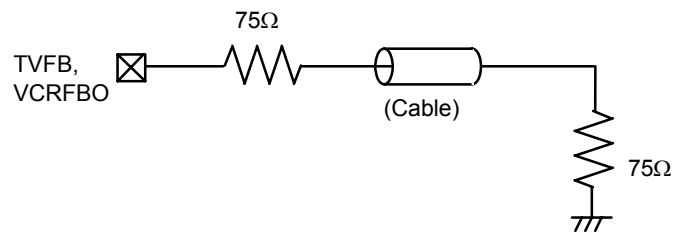

PACKAGE

48pin LQFP (Unit: mm)

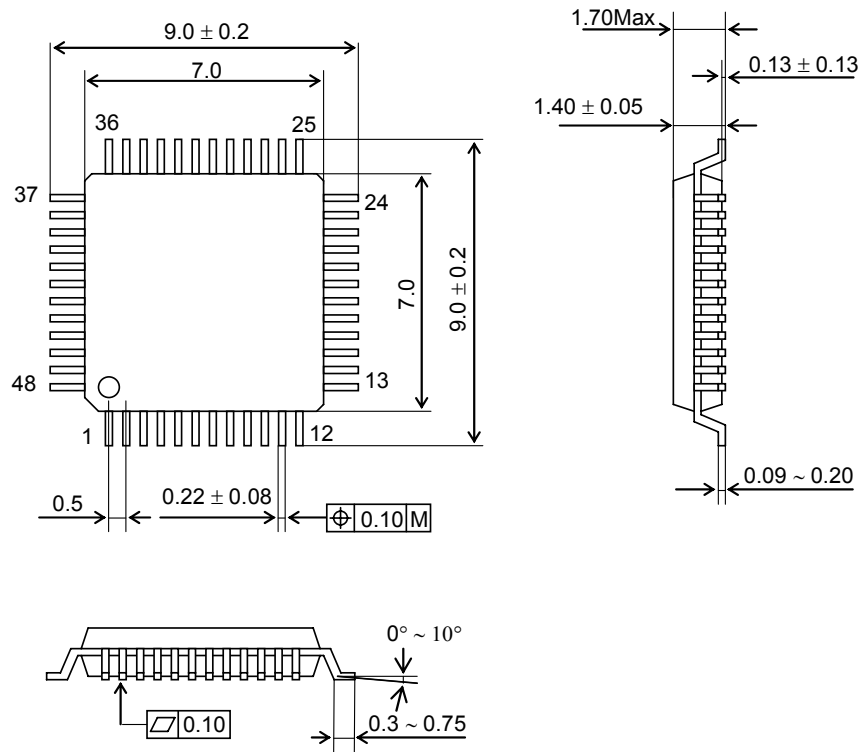

■ Package & Lead frame material

- Package molding compound: Epoxy
- Lead frame material: Cu
- Lead frame surface treatment: Solder (Pb free) plate

MARKING

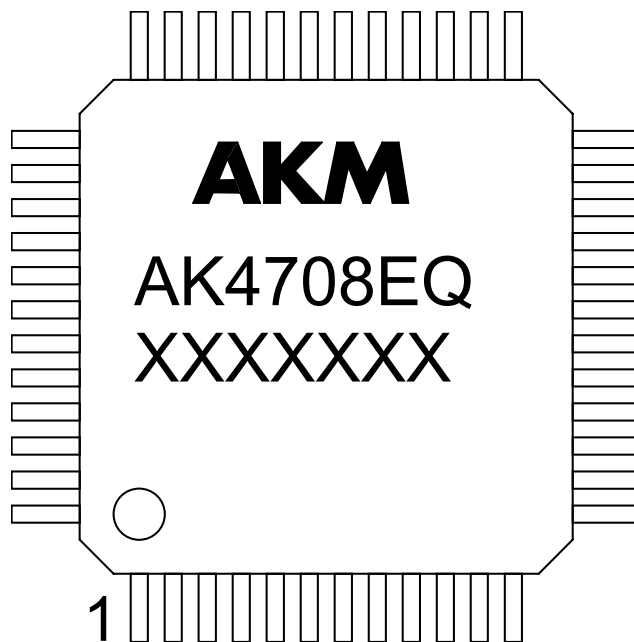

XXXXXXXX: Date code identifier

REVISION HISTORY

Date (YY/MM/DD)	Revision	Reason	Page	Contents
07/04/25	00	First Edition		
09/09/16	01	Specification Change	44	PACKAGE Package dimensions were changed.

IMPORTANT NOTICE

- These products and their specifications are subject to change without notice.
When you consider any use or application of these products, please make inquiries the sales office of Asahi Kasei Microdevices Corporation (AKM) or authorized distributors as to current status of the products.
- AKM assumes no liability for infringement of any patent, intellectual property, or other rights in the application or use of any information contained herein.
- Any export of these products, or devices or systems containing them, may require an export license or other official approval under the law and regulations of the country of export pertaining to customs and tariffs, currency exchange, or strategic materials.
- AKM products are neither intended nor authorized for use as critical components_{Note1)} in any safety, life support, or other hazard related device or system_{Note2)}, and AKM assumes no responsibility for such use, except for the use approved with the express written consent by Representative Director of AKM. As used here:
 - Note1) A critical component is one whose failure to function or perform may reasonably be expected to result, whether directly or indirectly, in the loss of the safety or effectiveness of the device or system containing it, and which must therefore meet very high standards of performance and reliability.
 - Note2) A hazard related device or system is one designed or intended for life support or maintenance of safety or for applications in medicine, aerospace, nuclear energy, or other fields, in which its failure to function or perform may reasonably be expected to result in loss of life or in significant injury or damage to person or property.
- It is the responsibility of the buyer or distributor of AKM products, who distributes, disposes of, or otherwise places the product with a third party, to notify such third party in advance of the above content and conditions, and the buyer or distributor agrees to assume any and all responsibility and liability for and hold AKM harmless from any and all claims arising from the use of said product in the absence of such notification.