

# AKD5358B-B

## AK5358B Evaluation Board Rev.0

**GENERAL DESCRIPTION**

AKD5358B-B is an evaluation board for the digital audio 24bit 96kHz A/D converter, AK5358B. AKD5358B-B has analog input circuits and a digital interface transmitter, and can achieve the interface with digital audio systems via opt-conductor.

■ **Ordering guide**

AKD5358B-B --- AK5358B Evaluation Board

**FUNCTION**

- **DIT (AK4114) with optical output**

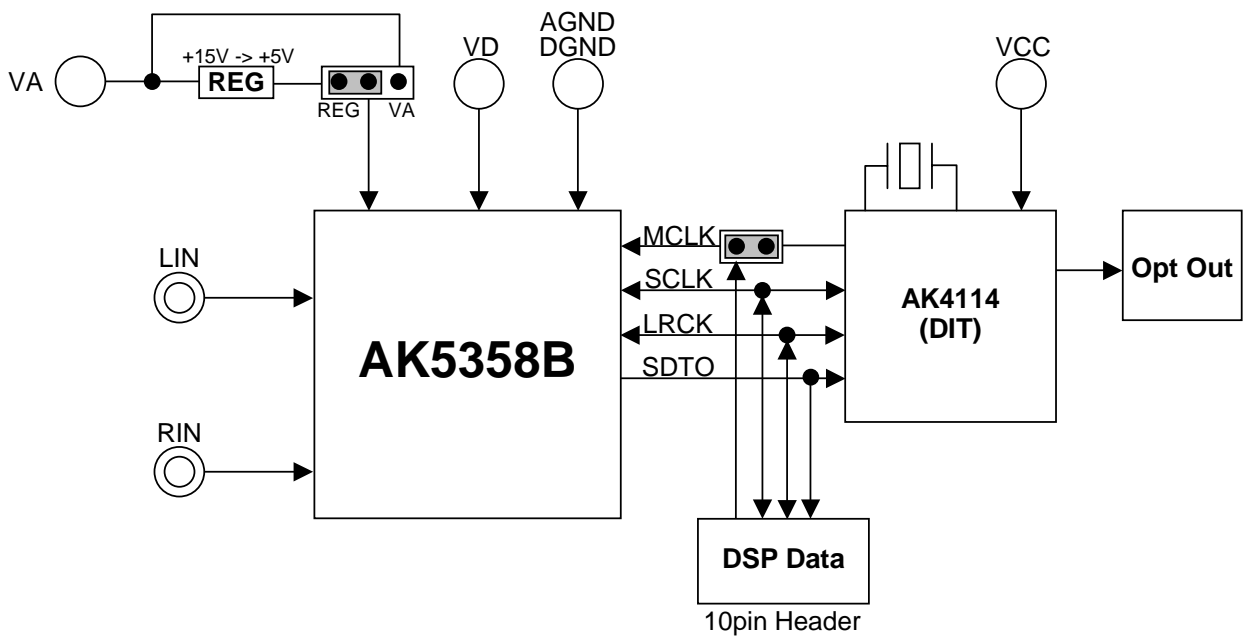

Figure 1. AKD5358B-B Block Diagram

\* Circuit diagram and PCB layout are attached at the end of this manual.

**1. Evaluation Board Manual**

**■ Operation sequence**

1) Set up the power supply lines.

Jack Names	Jack Colors	Voltage Ranges	Used for	Comments and attentions	Default
VA (Note 1)	Red	+7V ~ +15V	ReguratorT1: VA of AK5358B	Should be always connected.	+15V
VD	Orange	+2.7V ~ +5.5V	VD of AK5358B, 74HC14	Should be always connected.	+5V
VCC	Green	+3.0V ~ +3.6V	AK4114	Should be always connected.	+3.3V
AGND	Black	0V	Analog Ground	Should be always connected.	GND
DGND	Black	0V	Digital Ground	Should be always connected.	GND

Table 1. Set up the power supply lines.

Note 1. In case of using +5V power supply to connect VD, It is possible to supply the voltage to VD of AK5358B without using Regurator(T1). In this case, JP3 is set to VD side.

Each supply line should be distributed from the power supply unit.

2) Set up the evaluation mode, jumper pins and DIP switches. (See the followings.)

3) Power on.

The AK5358B and AK4114 should be reset once bringing SW2 = “L” upon power-up.

**■ Evaluation mode**

(1) Slave Mode

(1-1) A/D evaluation using DIT function of AK4114

PORT2 (DIT) is used. DIT generates audio bi-phase signal from received data and which is output through optical connector (TOTX141). It is possible to connect AKM’s D/A converter evaluation boards on the digital-amplifier, which equips DIR input. Nothing should be connected to PORT1 (DSP).

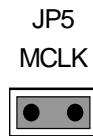

Figure 2. Jumper setting, when using DIT function of AK4114

(1-2) All interface signals including master clock are fed externally.

PORT1 (DSP) is used. All interface signals (MCLK, SCLK, LRCK) are provided to the AK5358B through PORT1. JP5 (MCLK) should be open. The DIF1 of SW1 (MODE) should be set to “H”.

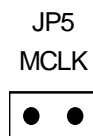

Figure 3. Jumper setting, when using PORT1(DSP)

## (2) Master Mode

## (2-1) A/D evaluation using DIT function of AK4114

PORT2 (DIT) is used. DIT generates audio bi-phase signal from received data and which is output through optical connector (TOTX141). It is possible to connect AKM's D/A converter evaluation boards on the digital-amplifier, which equips DIR input. Nothing should be connected to PORT1 (DSP). The DIF1 of SW1 (MODE) should be set to "H".

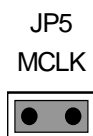

Figure 4. Jumper setting, when using DIT function of AK4114

## (2-2) Master clock is fed externally.

PORT1 (DSP) is used. MCLK is provided to the AK5358B through PORT1. JP5 (MCLK) should be open. The DIF1 of SW1 (MODE) should be set to "H".

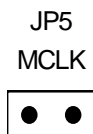

Figure 5. Jumper setting, when using PORT1(DSP)

### ■ Other jumper pins set up

1. JP1 (GND) : Analog ground and Digital ground  
 OPEN : Separated.  
 SHORT: Common. (The connector "DGND" can be open.) <Default>
2. JP2 (CKS1) : Setting of CKS1 pin for AK5358B  
 H : Master mode  
 L : Slave mode <Default>
3. JP3 (VA) : Select VA for AK5358B  
 VA : 5V Supply from VA connector <Default>  
 REG : 5V Supply from regulator. VA connector should be supplied +7~15V.
4. JP4 (VD) : Select VD for AK5358B  
 Select VD

## ■ DIP Switch set up

[SW1] (MODE1): Setting the evaluation mode for AK5358B and AK4114  
ON is “H”, OFF is “L”. CKS1 should be set by JP2.

No.	Name	OFF (“L”)	ON (“H”)
1	CKS0	See Table 2 (Note 2)	
2	CKS2		
3	DIF	MSB justified	I <sup>2</sup> S Compatible
4	DIF1	AK4114 Master mode	AK4114 Slave mode

Table 2. Mode Setting

Mode	CKS2	CKS1	CKS0	Input Level	Master/Slave	MCLK	SCLK
0	L	L	L	CMOS	Slave	256/384fs (8kHz≤fs≤96kHz) 512/768fs (8kHz≤fs≤48kHz)	≥ 48fs or 32fs
1	L	L	H	Reserved			
2	L	H	L	CMOS	Master	256fs (8kHz≤fs≤96kHz)	64fs
3	L	H	H	CMOS	Master	512fs (8kHz≤fs≤48kHz)	64fs
4	H	L	L	TTL	Slave	256/384fs (~ 96kHz) 512/768fs (~ 48kHz)	≥ 48fs or 32fs
5	H	L	H	Reserved			
6	H	H	L	CMOS	Master	384fs (8kHz≤fs≤96kHz)	64fs
7	H	H	H	CMOS	Master	768fs (8kHz≤fs≤48kHz)	64fs

Table 3. Mode Setting of AK5358B

Note 2: AK4114 does not support MCLK=384fs/512fs/768fs.  
PORT1 (DSP) should be used when MCLK=384fs/512fs/768fs.

## ■ The function of the toggle SW

Upper-side is “H” and lower-side is “L”.

[SW2] (PDN): Resets the AK5358B and AK4114. Keep “H” during normal operation.

■ Analog Input Circuits

Analog signal is input via J1(RIN) and J2(LIN) of RCA connectors.

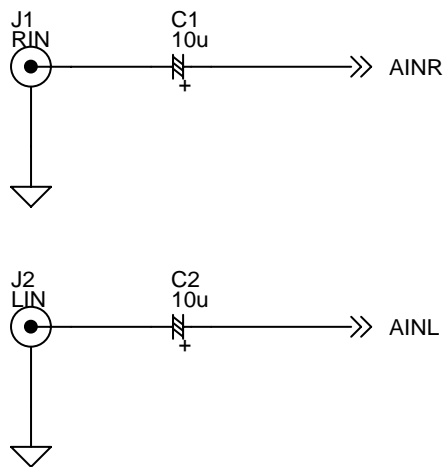

Figure 6. Analog Input circuits

\* AKM assumes no responsibility for the trouble when using the circuit examples.

<b>MEASUREMENT RESULTS</b>
----------------------------

[Measurement condition]

- Measurement unit : Audio Precision, System Two Cascade
- MCLK : 256fs
- SCLK : 64fs
- fs : 48kHz, 96kHz
- Bit : 24bit
- Power Supply : VA = 5.0V, VD = 5.0V
- Interface : DIT
- Temperature : Room

fs=48kHz

Parameter	Input signal	Measurement filter	Results	
			L ch	R ch
S/(N+D)	1kHz, -1dB	20kLPF	93.1 dB	93.0 dB
DR	1kHz, -60dB	20kLPF	99.6 dB	99.8 dB
		20kLPF, A-weighted	102.1 dB	102.6 dB
S/N	No input	20kLPF	100.0 dB	99.9 dB
		20kLPF, A-weighted	103.0 dB	102.8 dB

fs=96kHz

Parameter	Input signal	Measurement filter	Results	
			L ch	R ch
S/(N+D)	1kHz, -1dB	40kLPF	95.1 dB	94.9 dB
DR	1kHz, -60dB	40kLPF	99.4 dB	99.4 dB
		40kLPF, A-weighted	104.6 dB	104.7 dB
S/N	No input	40kLPF	99.5 dB	99.4 dB
		40kLPF, A-weighted	105.0 dB	104.8 dB

[ADC Plot : fs=48kHz]  
AKM

AK5358B S/(N+D) vs. Input Level  
VA=VD=5V, fs=48kHz, fin=1kHz

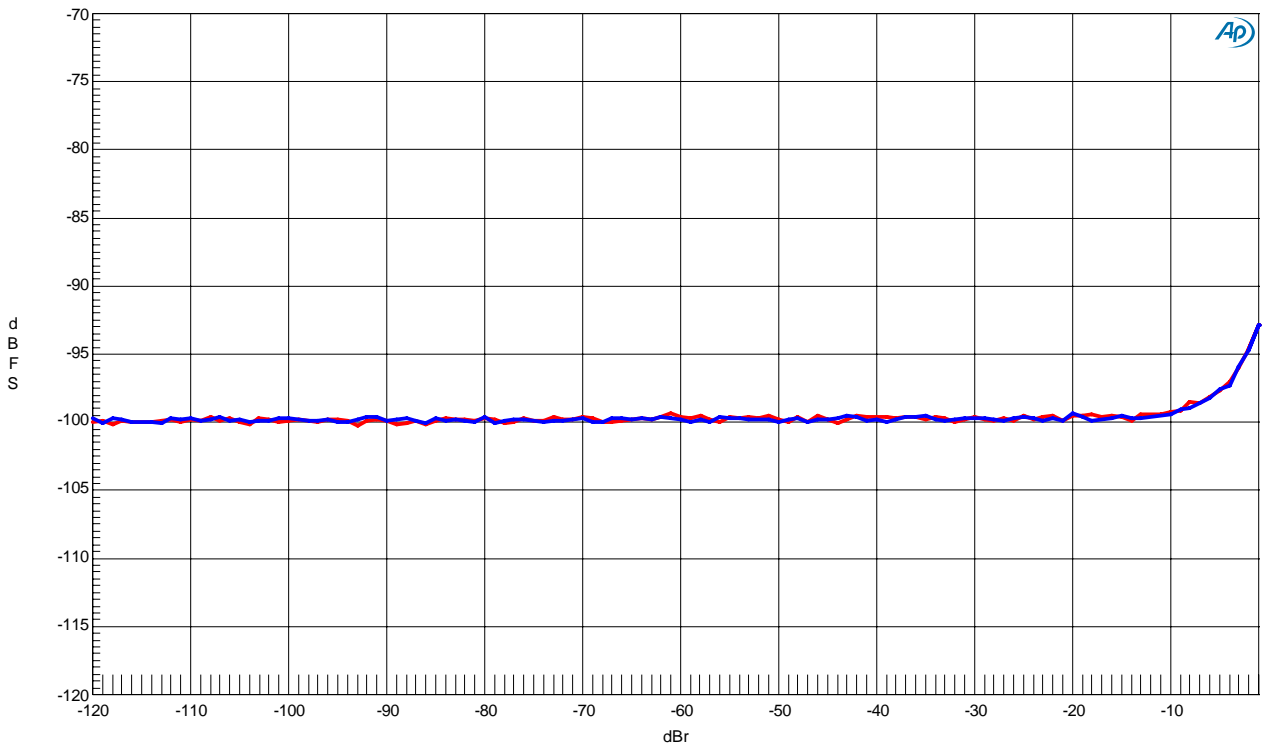

Figure 7. S/(N+D) vs. Input Level

AKM

AK5358B S/(N+D) vs. Input Frequency  
VA=VD=5V, fs=48kHz, Input Level=-1dBr

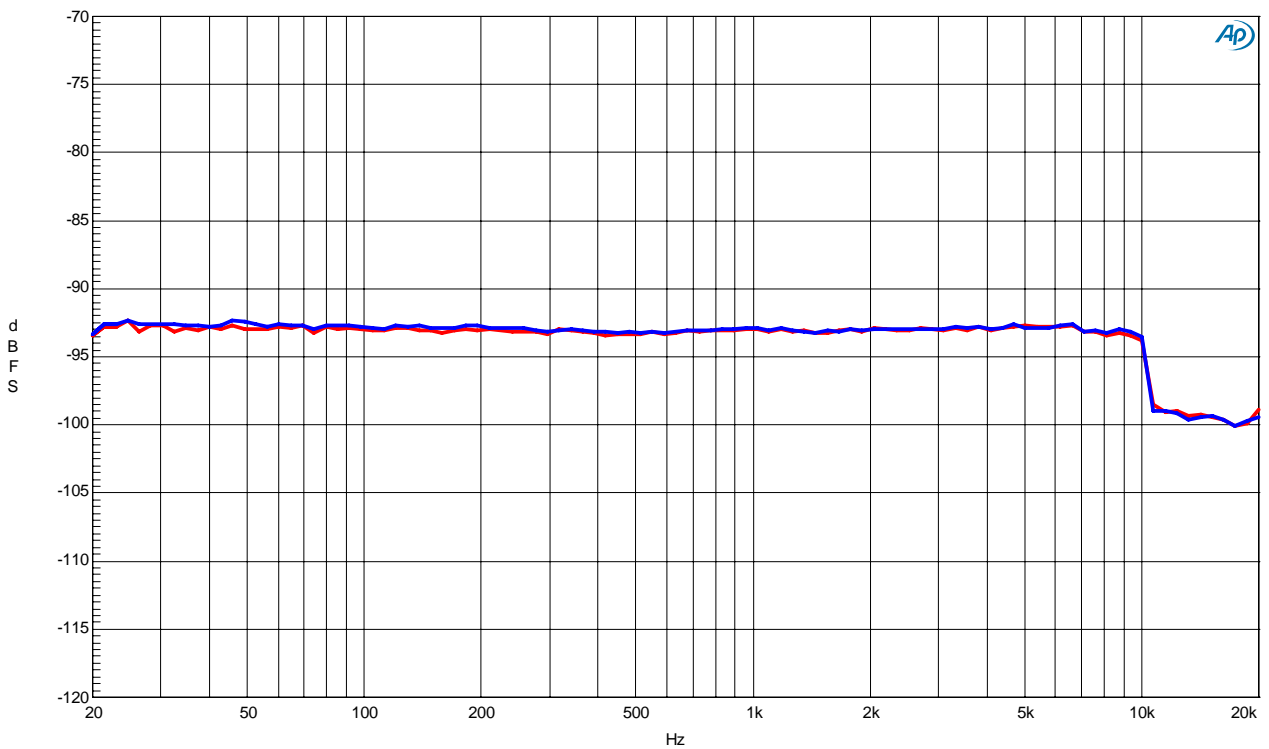

Figure 8. S/(N+D) vs. Input Frequency

AKM

AK5358B Linearity  
VA=VD=5V, fs=48kHz, fin=1kHz

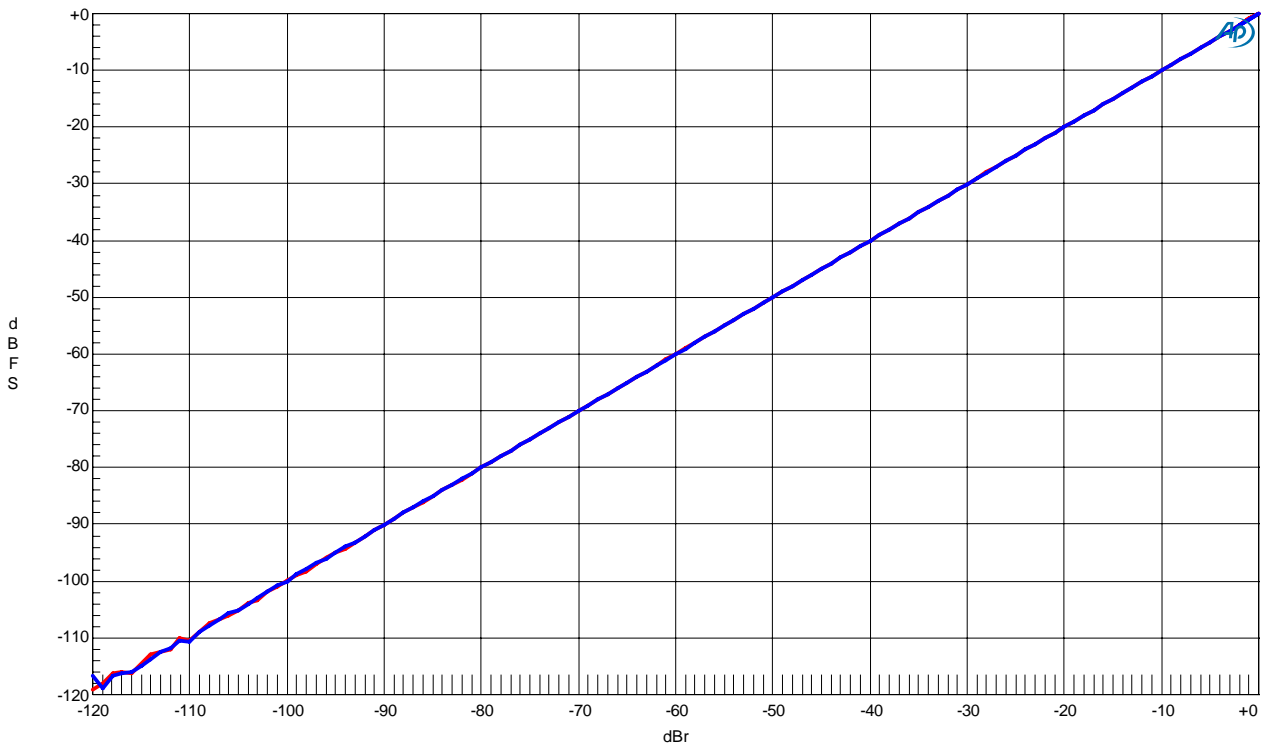

Figure 9. Linearity

AKM

AK5358B Frequency Response  
VA=VD=5V, fs=48kHz, Input Level=-1dBr

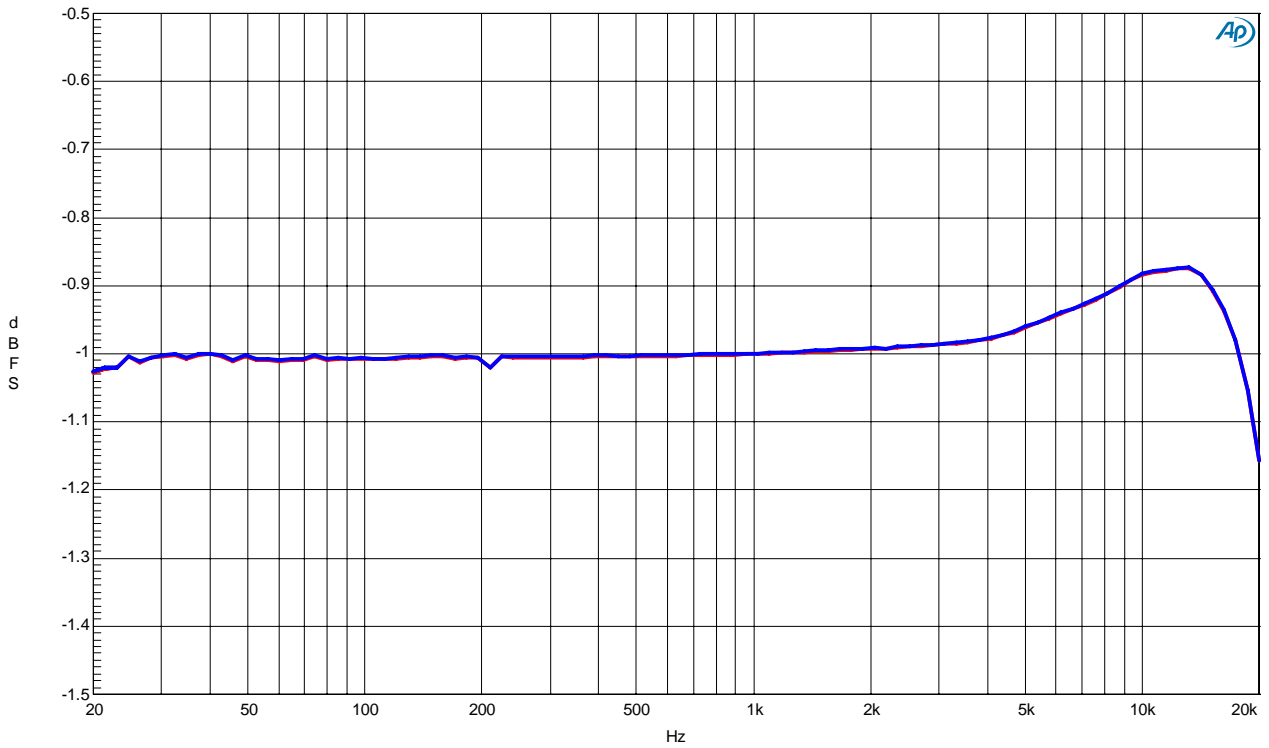

Figure 10. Frequency Response

AKM

AK5358B Crosstalk  
VA=VD=5V, fs=48kHz, Input Level=-1dBr

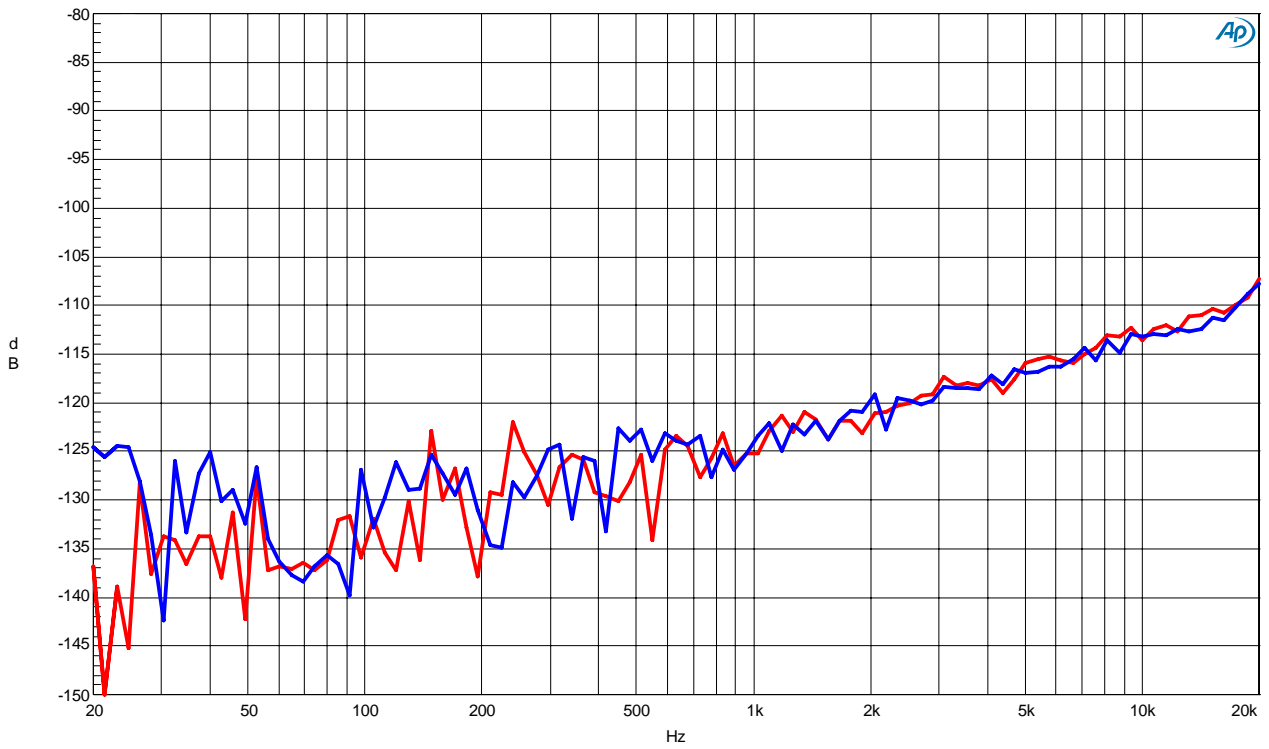

Figure 11. Crosstalk

AKM

AK5358B FFT  
VA=VD=5V, fs=48kHz, fin=1kHz, Input Level=-1dBr

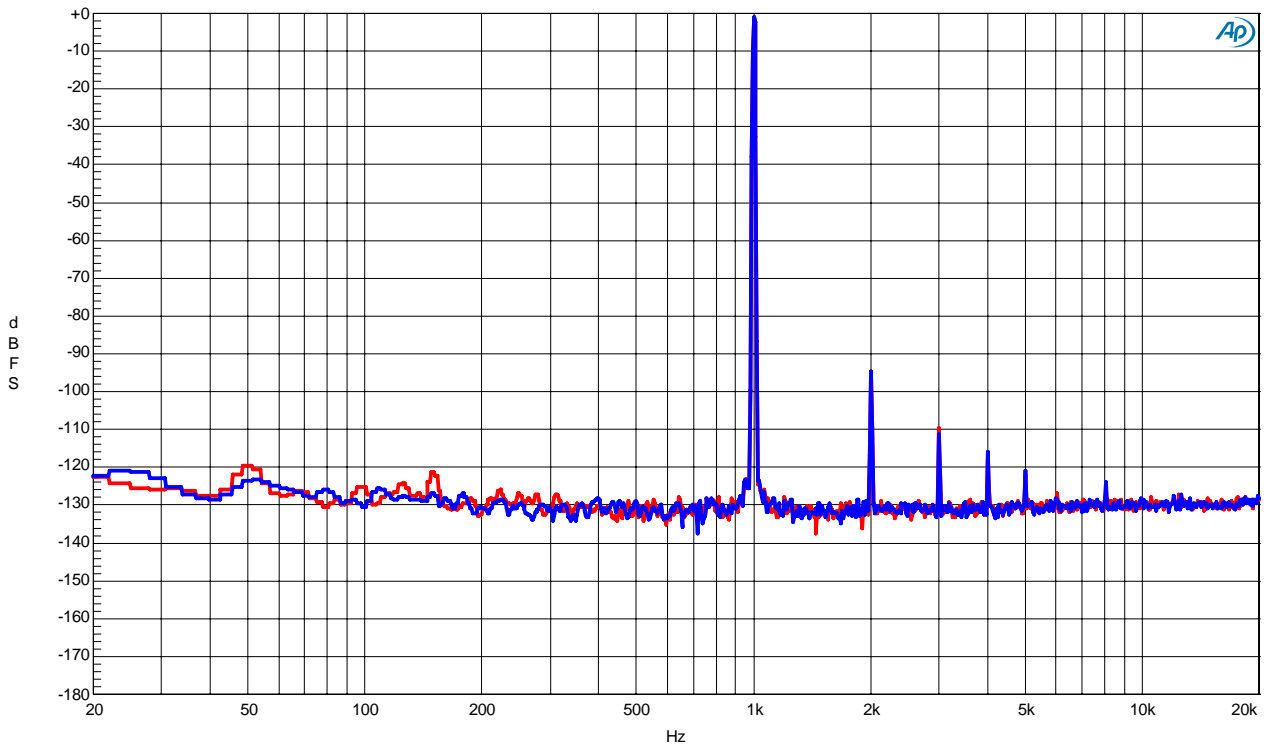

Figure 12. FFT Plot

AKM

AK5358B FFT  
VA=VD=5V, fs=48kHz, fin=1kHz, Input Level=-60dB

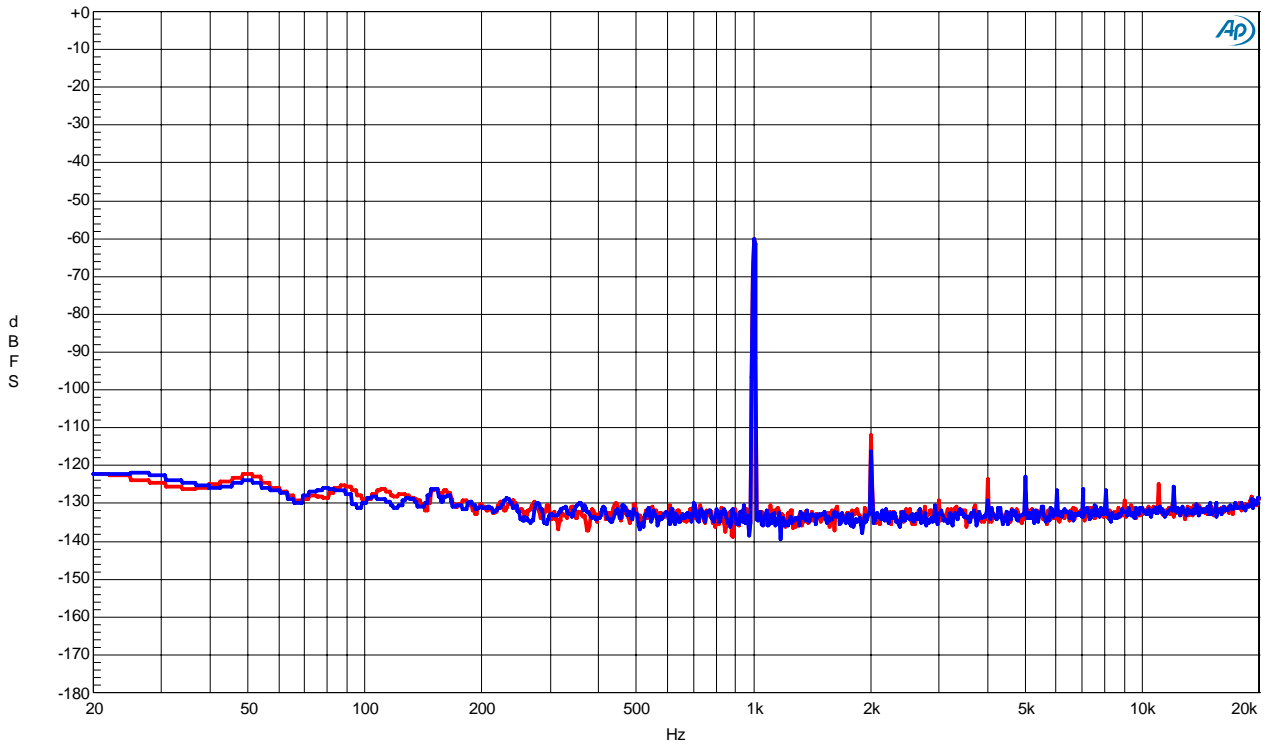

Figure 13. FFT Plot

AKM

AK5358B FFT  
VA=VD=5V, fs=48kHz, fin=1kHz, Input Level=No Signal

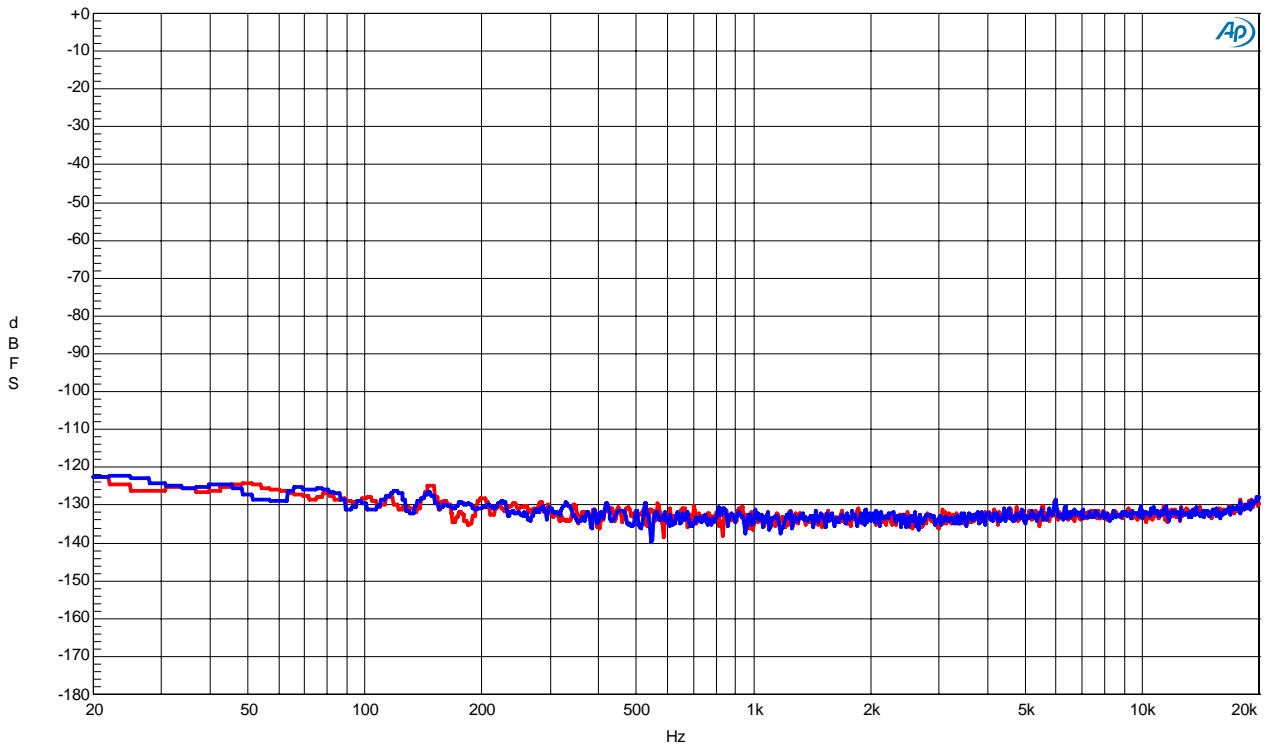

Figure 14. FFT Plot

[ADC Plot : fs=96kHz]  
AKM

AK5358B S/(N+D) vs. Input Level  
VA=VD=5V, fs=96kHz, fin=1 kHz

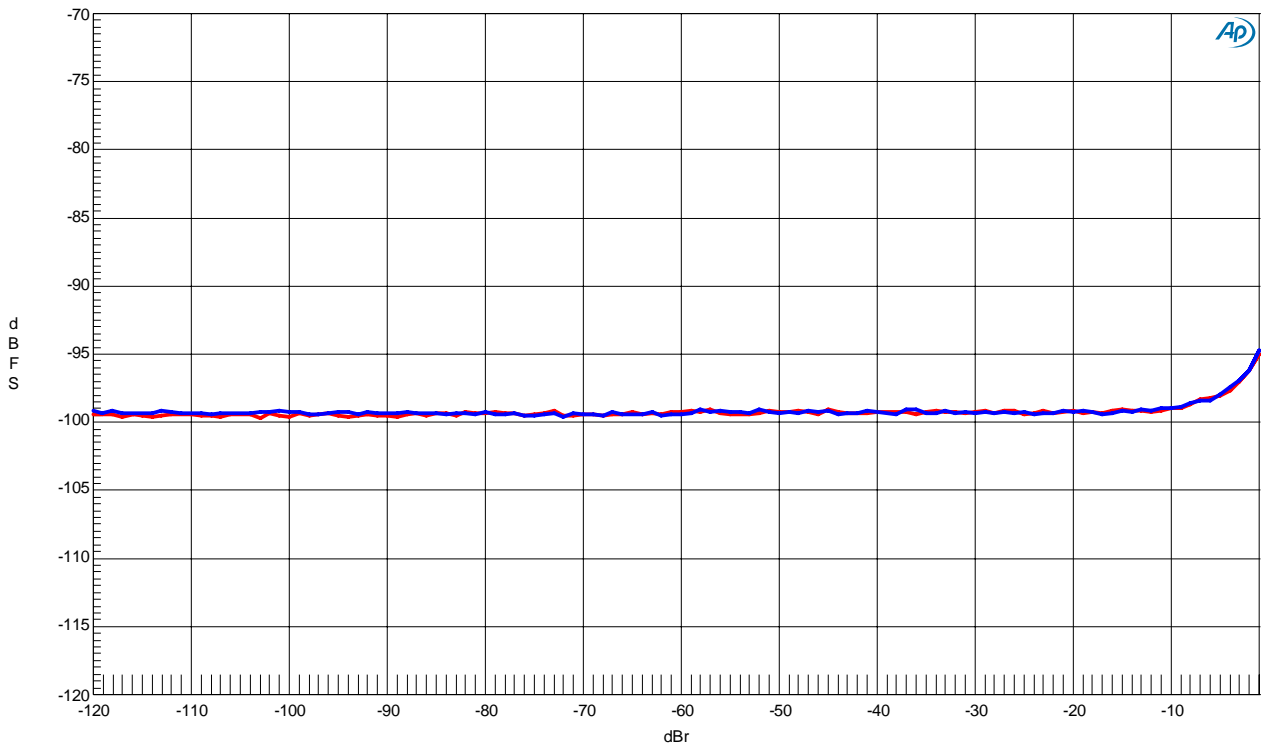

Figure 15. S/(N+D) vs. Input Level

AKM

AK5358B S/(N+D) vs. Input Frequency  
VA=VD=5V, fs=96kHz, Input Level=-1dBr

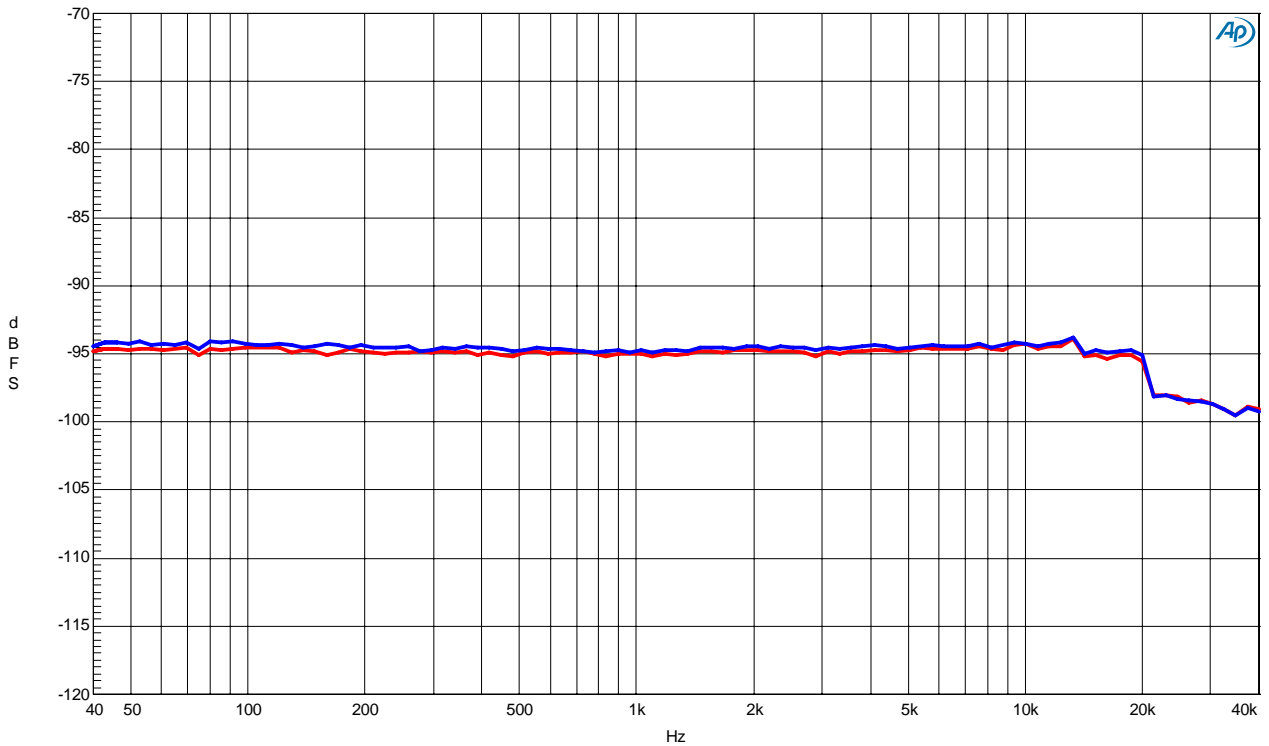

Figure 16. S/(N+D) vs. Input Frequency

AKM

AK5358B Linearity  
VA=VD=5V, fs=96kHz, fin=1 kHz

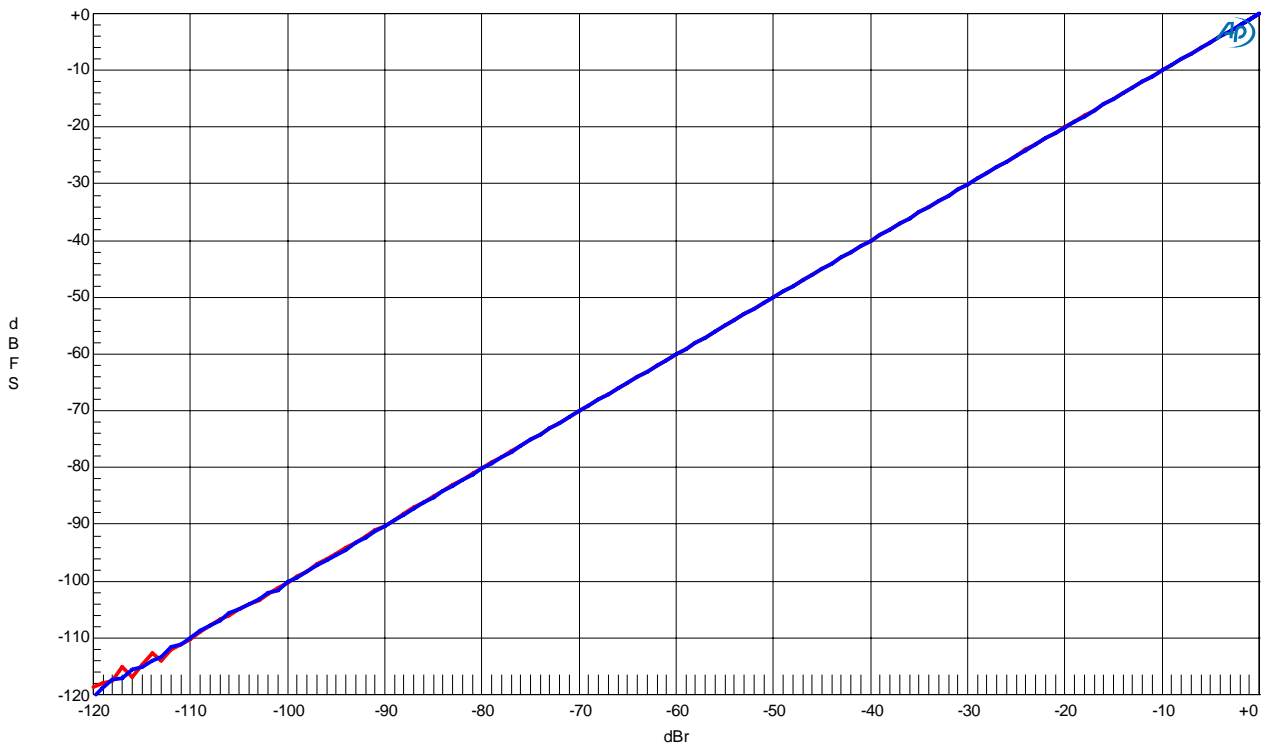

Figure 17. Linearity

AKM

AK5358B Frequency Response  
VA=VD=5V, fs=96kHz, Input Level=-1dBr

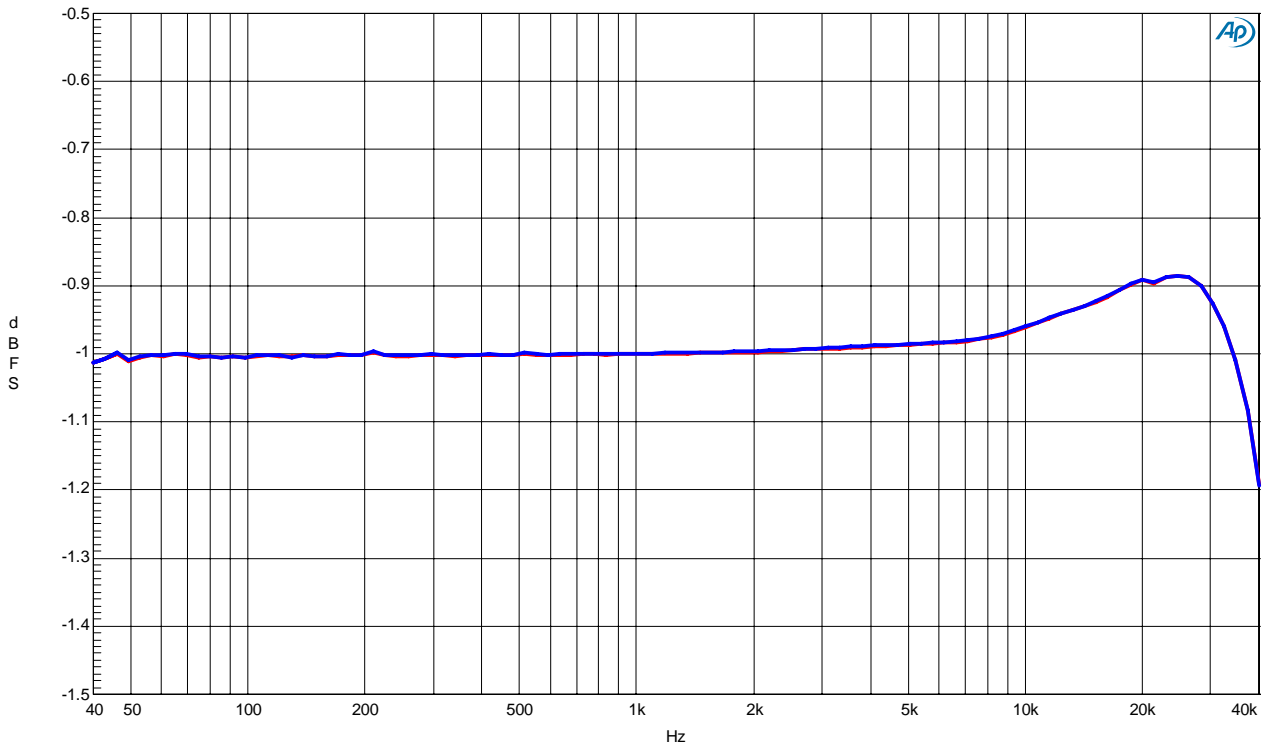

Figure 18. Frequency Response

AKM

AK5358B Crosstalk  
VA=VD=5V, fs=96kHz, Input Level=-1dBr

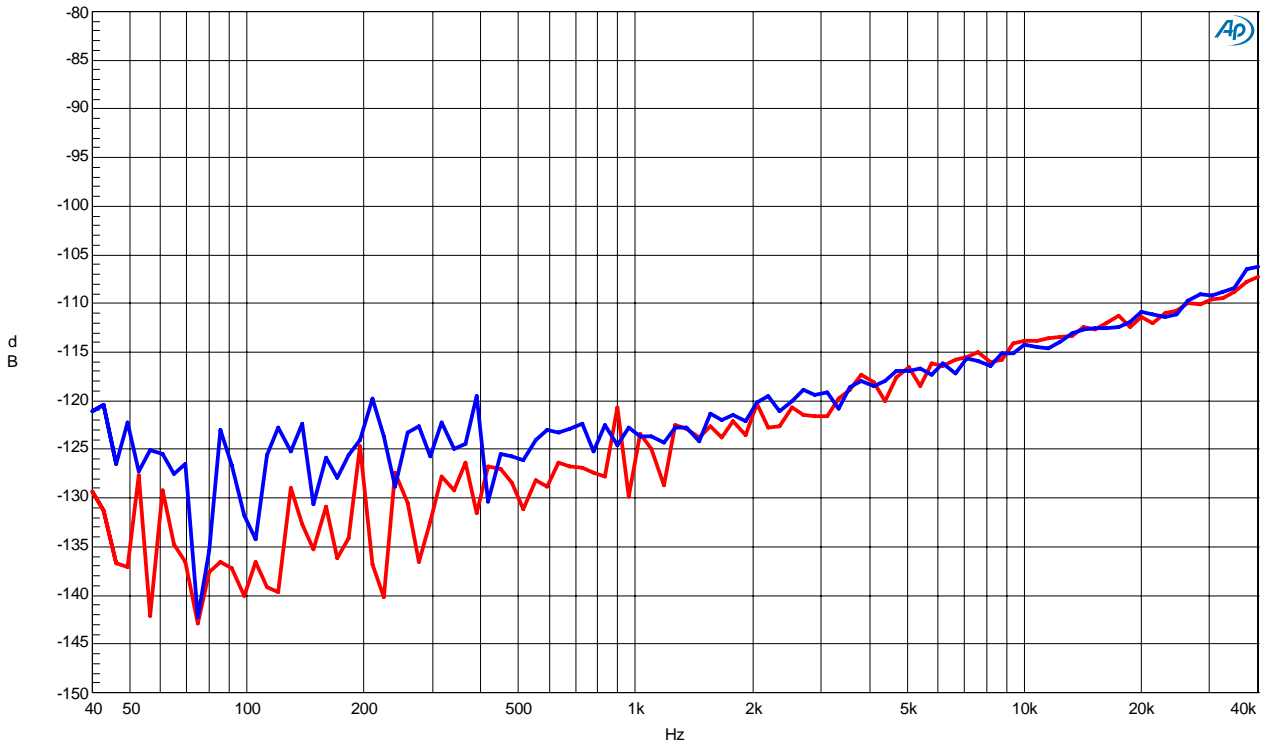

Figure 19. Crosstalk

AKM

AK5358B FFT  
VA=VD=5V, fs=96kHz, fin=1kHz, Input Level=-1dBr

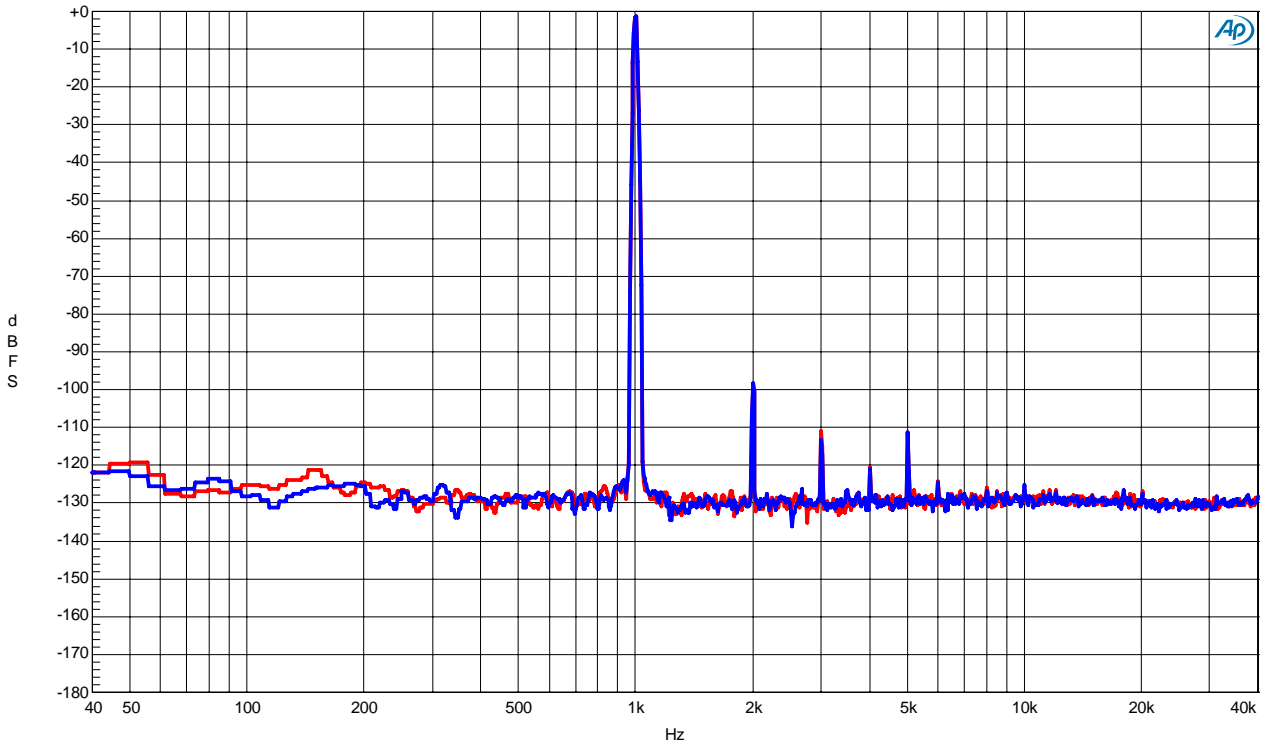

Figure 20. FFT Plot

AKM

AK5358B FFT  
VA=VD=5V, fs=96kHz, fin=1kHz, Input Level=-60dB

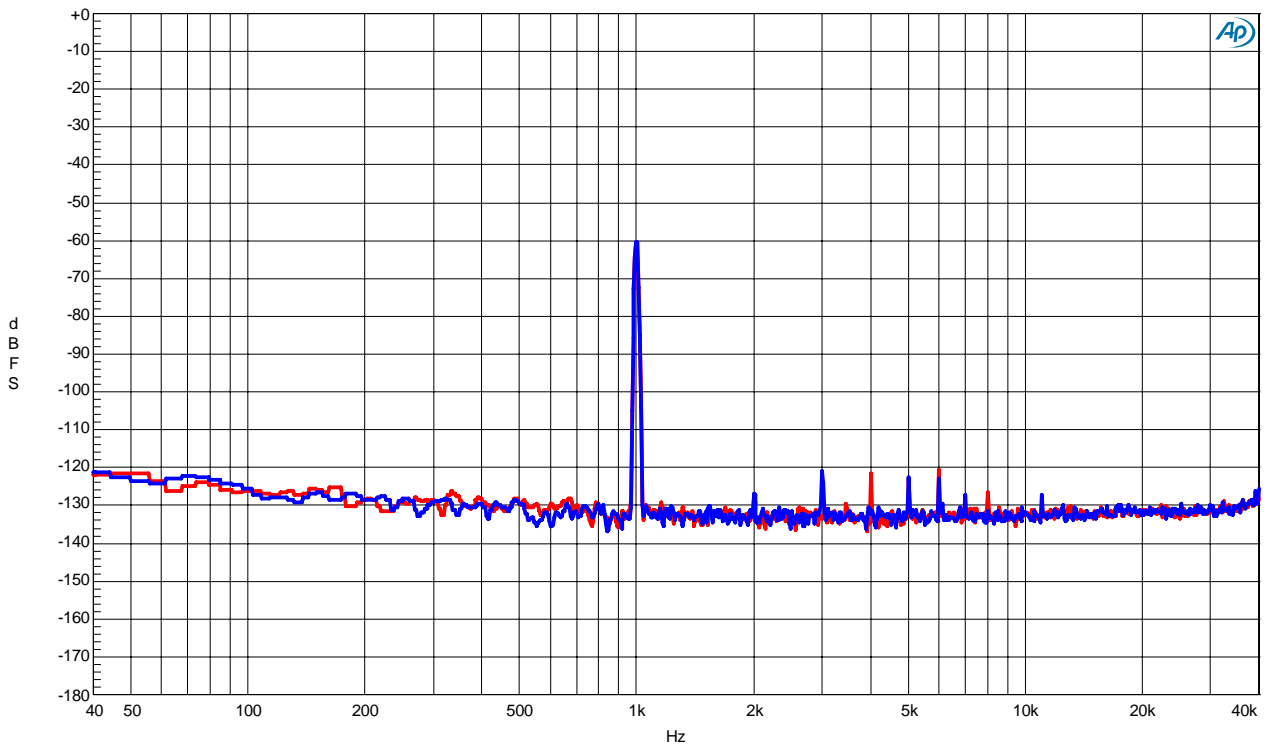

Figure 21. FFT Plot

AKM

AK5358B FFT  
VA=VD=5V, fs=96kHz, fin=1kHz, Input Level=No Signal

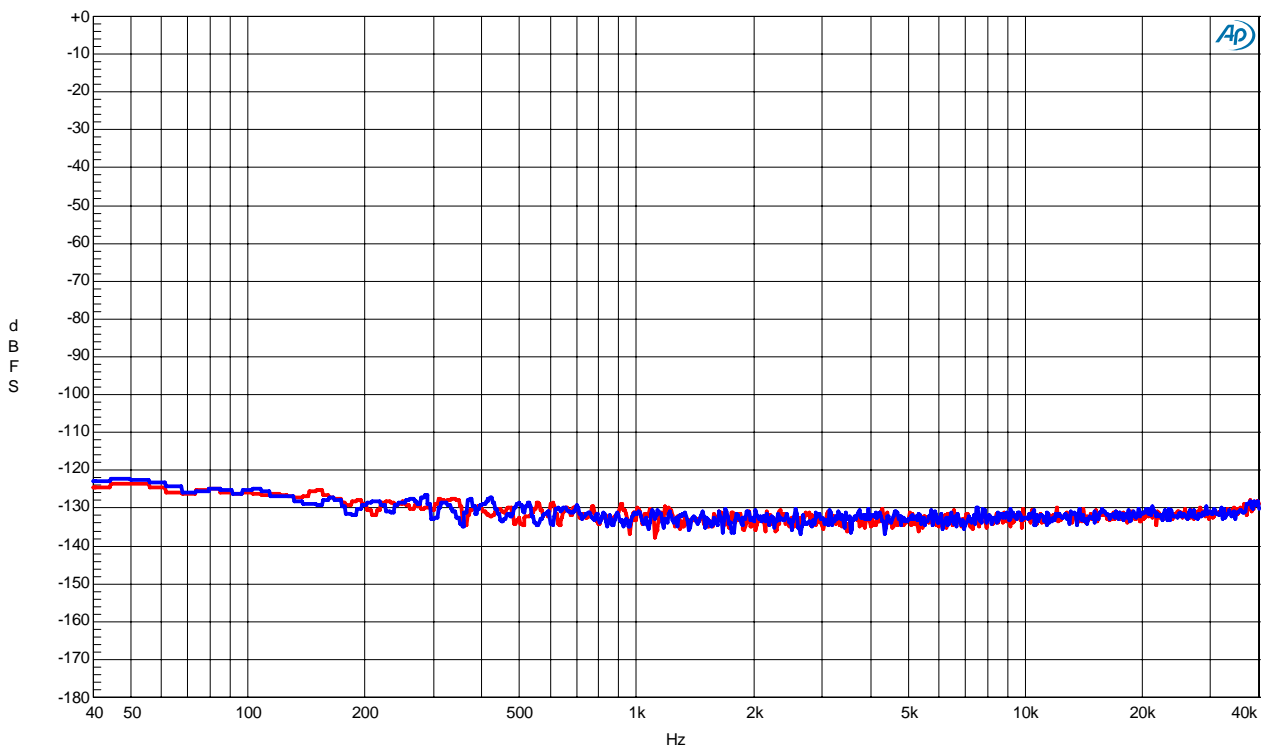

Figure 22. FFT Plot

<b>REVISION HISTORY</b>
-------------------------

Date (yy/mm/dd)	Manual Revision	Board Revision	Reason	Page	Contents
09/04/01	KM099500	0	First Edition		
09/08/28	KM099501	0	Change	1	“Figure 1. AKD5358B-B Block Diagram” was changed.
			Modification	6-14	Update of measurement results and Plots.
10/01/15	KM099502	0	Modification	6-14	Update of measurement results and Plots.

IMPORTANT NOTICE

- These products and their specifications are subject to change without notice.  
When you consider any use or application of these products, please make inquiries the sales office of Asahi Kasei Microdevices Corporation (AKM) or authorized distributors as to current status of the products.
- AKM assumes no liability for infringement of any patent, intellectual property, or other rights in the application or use of any information contained herein.
- Any export of these products, or devices or systems containing them, may require an export license or other official approval under the law and regulations of the country of export pertaining to customs and tariffs, currency exchange, or strategic materials.
- AKM products are neither intended nor authorized for use as critical components<sub>Note1</sub>) in any safety, life support, or other hazard related device or system<sub>Note2</sub>), and AKM assumes no responsibility for such use, except for the use approved with the express written consent by Representative Director of AKM. As used here:
  - Note1) A critical component is one whose failure to function or perform may reasonably be expected to result, whether directly or indirectly, in the loss of the safety or effectiveness of the device or system containing it, and which must therefore meet very high standards of performance and reliability.
  - Note2) A hazard related device or system is one designed or intended for life support or maintenance of safety or for applications in medicine, aerospace, nuclear energy, or other fields, in which its failure to function or perform may reasonably be expected to result in loss of life or in significant injury or damage to person or property.
- It is the responsibility of the buyer or distributor of AKM products, who distributes, disposes of, or otherwise places the product with a third party, to notify such third party in advance of the above content and conditions, and the buyer or distributor agrees to assume any and all responsibility and liability for and hold AKM harmless from any and all claims arising from the use of said product in the absence of such notification.

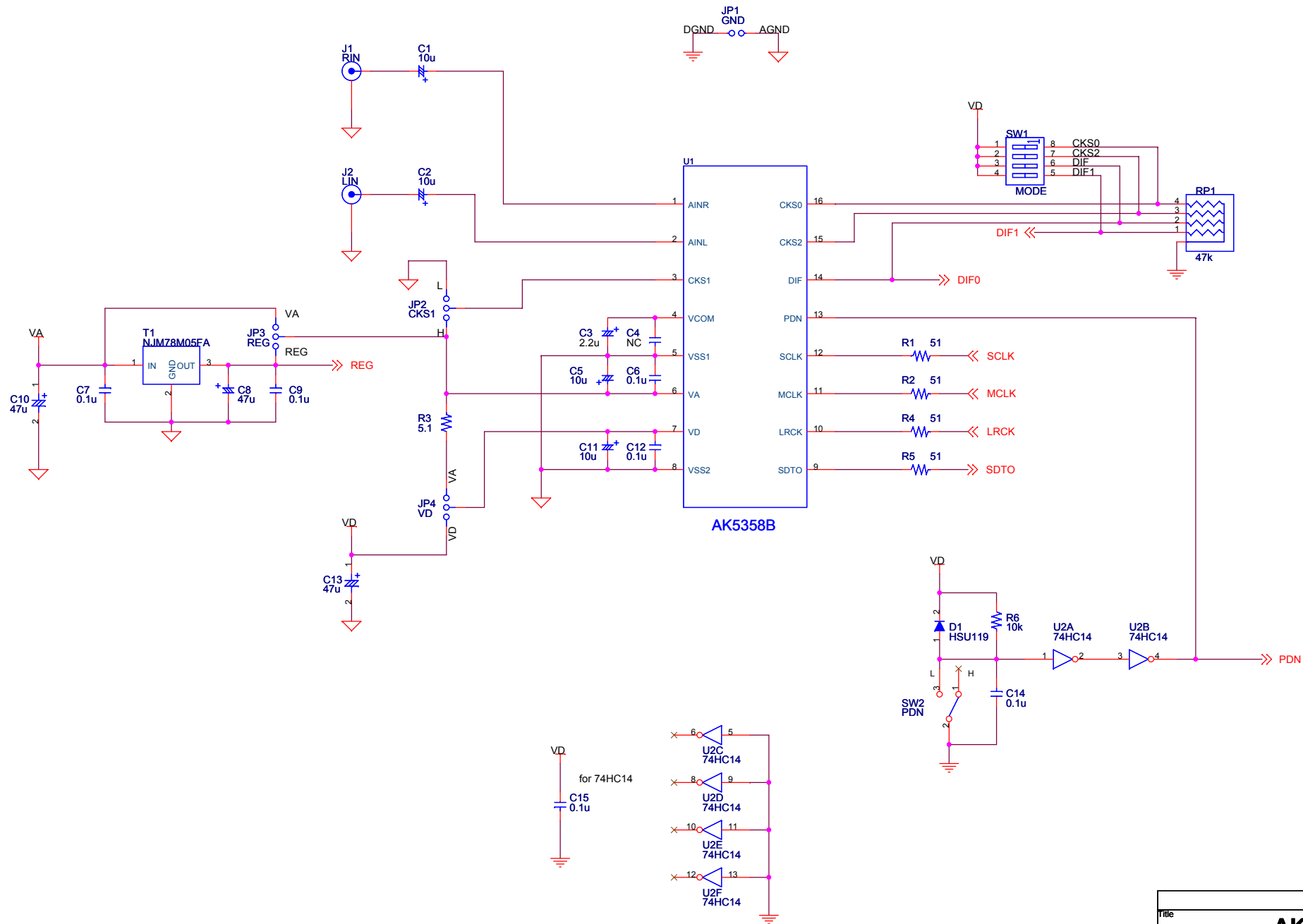

Title		
<b>AKD5358B-B</b>		
Size	Document Number	Rev
A3	<b>AK5358B</b>	<b>0</b>
Date:	<b>Monday, March 09, 2009</b>	Sheet 1 of 2

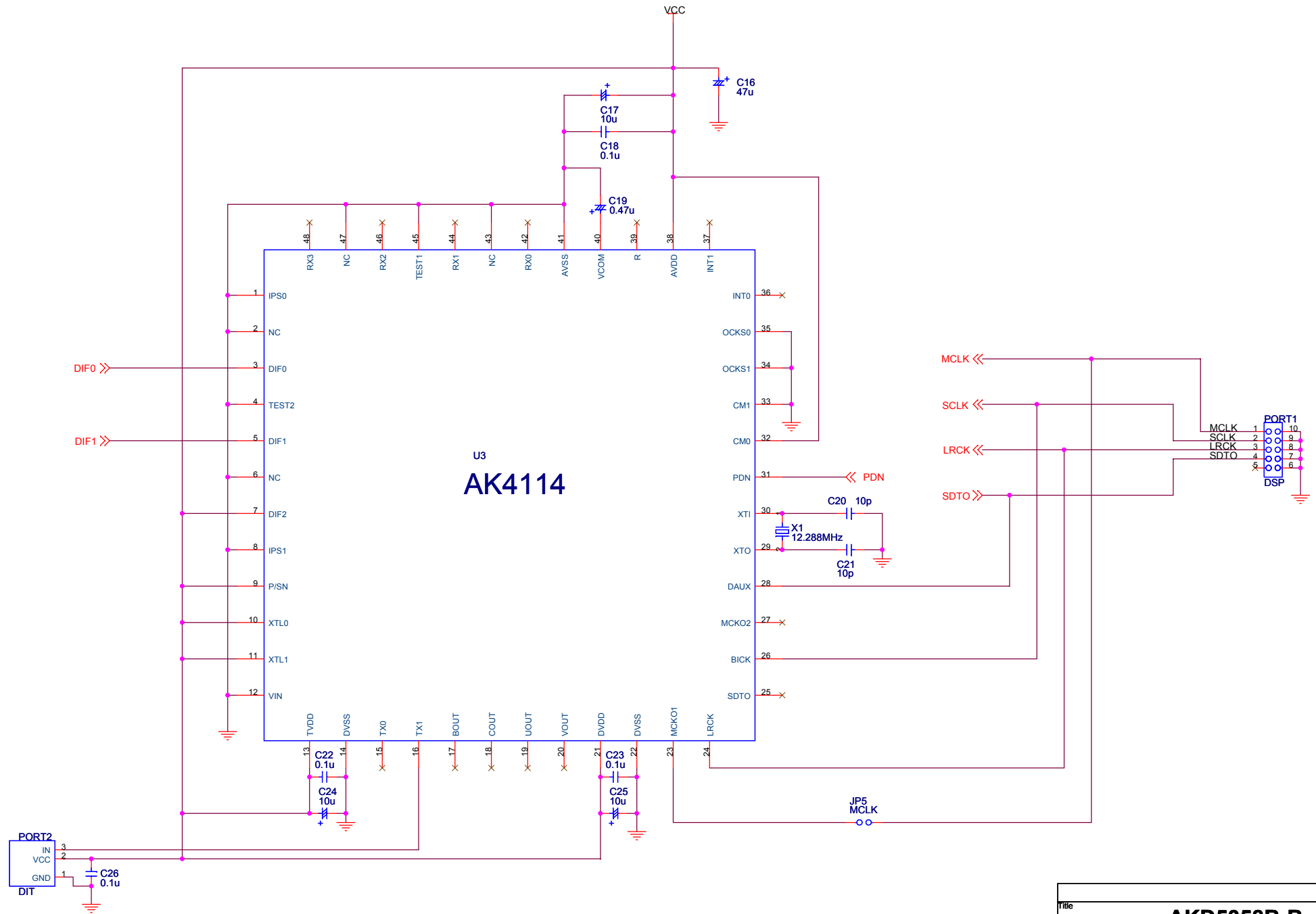

Title		<b>AKD5358B-B</b>	
Size	Document Number	<b>AK4114</b>	
A3			Rev <b>0</b>
Date:	Friday, March 06, 2009	Sheet	2 of 2

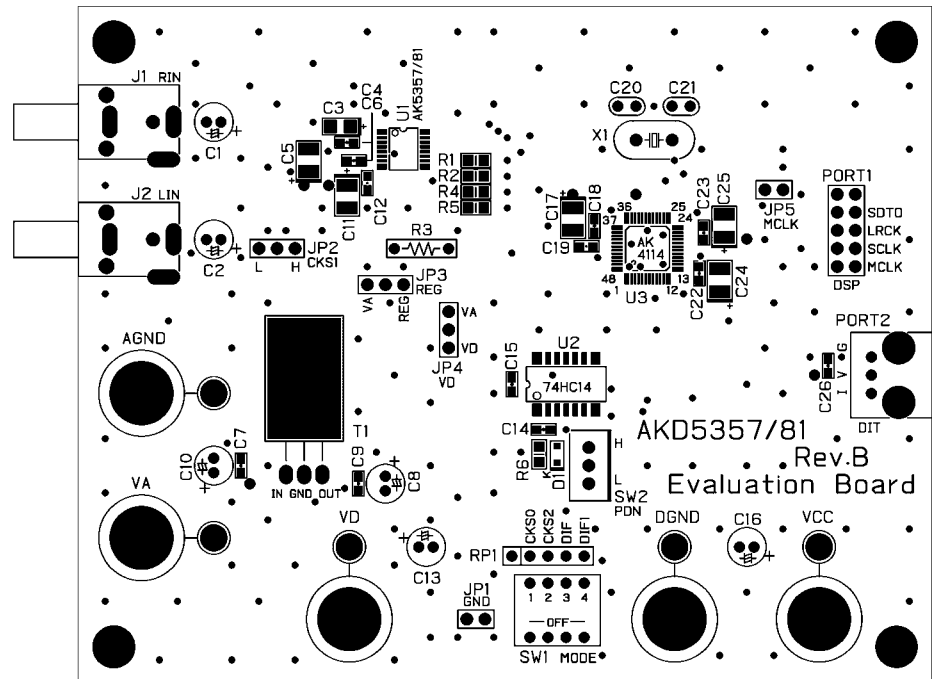

AKD5357/81 Rev.B L1 SR SILK

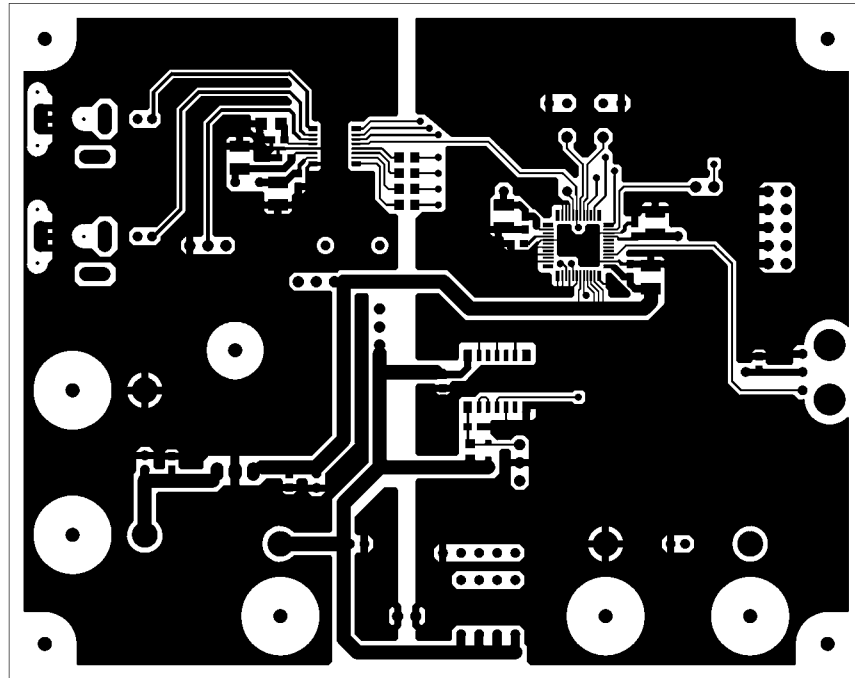

AKD5357/81 Rev.B L1

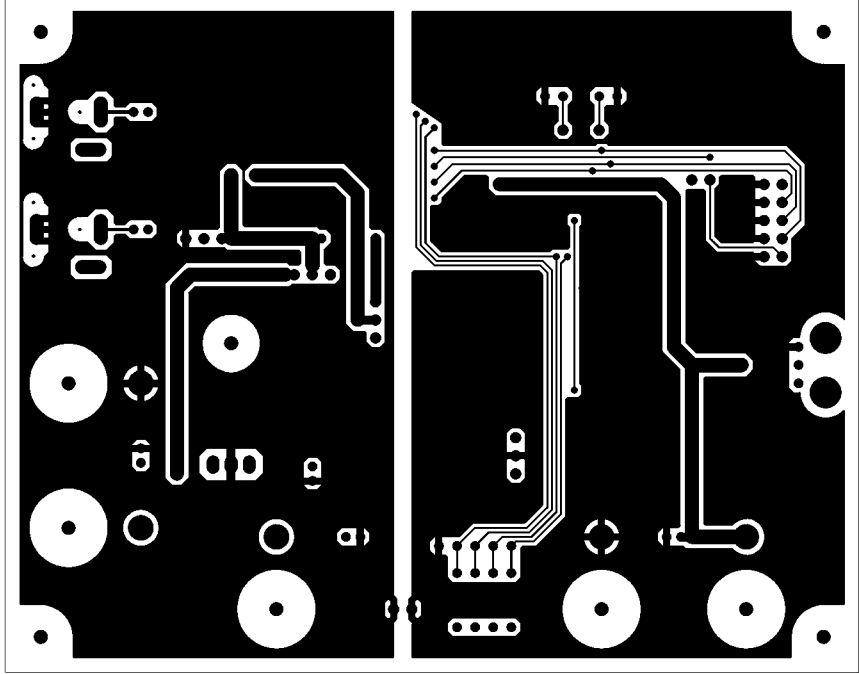

AKD9327\81 Rev.B LS