



# Low Power Multiclock Generator with VCXO

## AK8130

### Features

- 27MHz Crystal Input
- Four Frequency-Selectable Clock Outputs
- One 27MHz-Reference Output
- Selectable Clock out Frequencies:
  - 54.000,74.1758, 74.250MHz
  - 25.000MHz
  - 4.9152MHz
  - 24.576, 33.333MHz
- Built-in VCXO
  - Pull Range:  $\pm 110$ ppm (Min.)
- Low Jitter Performance
  - Period Jitter: 150 psec (Typ.) at CLK1-4
  - Long Term Jitter : 160 psec (Typ.) at REFOUT
- Low Current Consumption: 16.5mA (Typ.) at 3.3V
- Supply Voltage: 3.0 – 3.6V
- Operating Temperature Range: -20 to +85°C
- Package: 16-pin TSSOP (Lead free)

### Description

The AK8130 is a member of AKEMD's low power multi clock generator family designed for a feature rich DTV or STB, requiring a range of system clocks with high performance. The AK8130 generates different frequency clocks from a 27MHz crystal oscillator and provides them to up to four outputs configured by pin-setting. The on-chip VCXO accepts a voltage control input to allow the output clocks to vary by  $\pm 110$  ppm for synchronizing to the external clock system. Both circuitries of VCXO and PLL in AK8130 are derived from AKEMD's long-term-experienced clock device technology, and enable clock output to perform low jitter and to operate with very low current consumption. The AK8130 is available in a 16-pin SSOP package.

### Applications

- Digital TV Sets
- Personal Video Recorders
- Set-Top-Boxes
- Multi Media Receivers

### Block Diagram

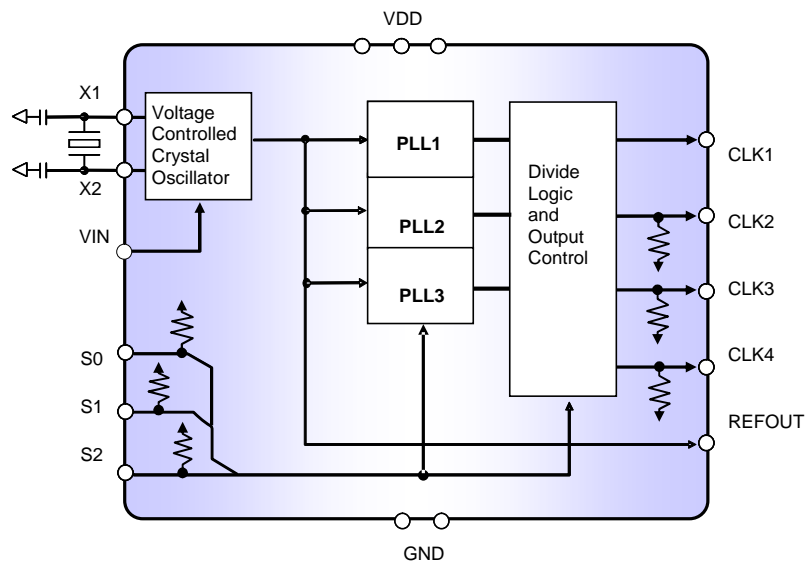

**AK8130 Multi Clock Generator**

## Pin Descriptions

Package: 16-Pin TSSOP(Top View)

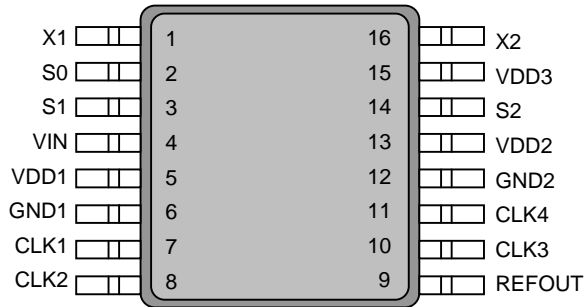

Pin No.	Pin Name	Pin Type	Description
1	X1	XO	Crystal connection, Connect to 27.000MHz crystal
2	S0	IN	Clock Out Frequency Select 0, See Table 1 for the selection (1)
3	S1	IN	Clock Out Frequency select 1, See Table 1 for the selection (1)
4	VIN	IN	VCXO Control Voltage Input
5	VDD1	--	Power Supply 1
6	GND1	--	Ground 1
7	CLK1	OUT	Clock output 1, See Table 1 for its selectable frequency
8	CLK2	OUT	Clock output 2, See Table 1 for its selectable frequency (2)
9	REF OUT	OUT	Reference Clock Output of VCXO based on 27.000MHz Crystal
10	CLK3	OUT	Clock output 3, See Table 1 for its selectable frequency (2)
11	CLK4	OUT	Clock output 4, See Table 1 for its selectable frequency (2)
12	GND2	--	Ground 2
13	VDD2	--	Power Supply 2
14	S2	IN	Clock Out Frequency select 1, See Table 1 for the selection (1)
15	VDD3	--	Power Supply 3
16	X2	XI	Crystal connection, Connect to 27.000MHz crystal

(1) Internal pull up 360kΩ

(2) Internal pull down 510kΩ

## Ordering Information

Part Number	Marking	Shipping Packaging	Package	Temperature Range
AK8130	8130	Tape and Reel	16-pin TSSOP	-20 to 85 °C

## Absolute Maximum Rating

Over operating free-air temperature range unless otherwise noted <sup>(1)</sup>

Items	Symbol	Ratings	Unit
Supply voltage	VDD	-0.3 to 4.6	V
Input voltage	V <sub>in</sub>	VSS-0.3 to VDD+0.3	V
Input current (any pins except supplies)	I <sub>IN</sub>	±10	mA
Storage temperature	T <sub>stg</sub>	-55 to 130	°C

Note

(1) Stress beyond those listed under “Absolute Maximum Ratings” may cause permanent damage to the device. These are stress ratings only. Functional operation of the device at these or any other conditions beyond those indicated under “Recommended Operating Conditions” is not implied. Exposure to absolute-maximum-rating conditions for extended periods may affect device reliability. Electrical parameters are guaranteed only over the recommended operating temperature range.



### ESD Sensitive Device

This device is manufactured on a CMOS process, therefore, generically susceptible to damage by excessive static voltage. Failure to observe proper handling and installation procedures can cause damage. AKEMD recommends that this device is handled with appropriate precautions.

## Recommended Operation Conditions

Parameter	Symbol	Conditions	Min	Typ	Max	Unit
Operating temperature	T <sub>a</sub>		-20		85	°C
Supply voltage <sup>(1)</sup>	VDD		3.0	3.3	3.6	V
Output Load Capacitance	C <sub>p1</sub>	Pin: CLK1-4			15	pF
	C <sub>p2</sub>	Pin: REFOUT			25	pF

Note:

(1) Power to VDD1, VDD2 and VDD3 requires to be supplied from a single source. A decoupling capacitor of 0.1μF for power supply line should be installed close to each VDD pin.

## DC Characteristics

All specifications at VDD: over 3.0 to 3.6V, Ta: -20 to +85°C, 27MHz Crystal, unless otherwise noted

Parameter	Symbol	Conditions	MIN	TYP	MAX	Unit
High Level Input Voltage	V <sub>IH</sub>	Pin: S0,S1,S2	0.7VDD			V
Low Level Input Voltage	V <sub>IL</sub>	Pin: S0,S1,S2			0.3VDD	V
Input Current 1	I <sub>L1</sub>	Pin: S0,S1,S2	-20		+10	μA
Input Current 2	I <sub>L2</sub>	PIN: VIN	-3		+3	μA
High Level Output Voltage	V <sub>OH</sub>	Pin: CLK1-4, REFOUT I <sub>OH</sub> =-4mA	0.8VDD			V
Low level Output Voltage	V <sub>OL</sub>	Pin: CLK1-4, REFOUT I <sub>OL</sub> =+4mA			0.2VDD	V
Current Consumption	I <sub>DD</sub>	Clock out selection by note <sup>(1)</sup> No load, Ta=25°C		16.5		mA

(1) Pin setting for output clock selection: [S2:S0] = HLH

## AC Characteristics

All specifications at VDD: over 3.0 to 3.6V, Ta: over -20 to +85°C, 27MHz Crystal, unless otherwise noted

Parameter	Symbol	Conditions	MIN	TYP	MAX	Unit
Crystal Clock Frequency				27.0000		MHz
VCXO Pullable Range <sup>(3)</sup>		VIN at over 0 to VDD V	±110			ppm
VCXO Gain	G <sub>VCXO</sub>	VIN range at 1.5V±1.0V		150		ppm/V
Period Jitter <sup>(4)</sup>		CLK1-4		150		ps
Long Term Jitter <sup>(5)</sup>		CLK1 at 54.000MHz 1000 cycle delay		0.5		ns
		CLK1 at 74.250MHz 1000 cycle delay		0.85		ns
		REFOUT at 27.000MHz 1000 cycle delay		160		ps
Output Clock Duty Cycle		Pin: CLK1-4 <sup>(1)</sup>	45	50	55	%
		Pin: REFOUT <sup>(2)</sup>	40	50	60	%
Output Clock Rise Time	t <sub>rise</sub>	Pin: CLK1-4 <sup>(1)</sup>		1.5		ns
		Pin: REFOUT <sup>(2)</sup>		2.5		ns
Output Clock Fall Time	t <sub>fall</sub>	Pin: CLK1-4 <sup>(1)</sup>		1.5		ns
		Pin: REFOUT <sup>(2)</sup>		2.5		ns
Power-up Time		Pin: CLK1-4 <sup>(1)</sup>		5		ms
Output Transition Time <sup>(6)</sup>		Pin: CLK1 at 74.25 or 74.175MHz		200		μs

(1) Measured with load capacitance of 15pF

(2) Measured with load capacitance of 25pF

(3) Pullable range depends on crystal characteristics, on-chip load capacitance, and stray capacity of PCB.  
Min. ±110ppm is applied to AKEMD's authorized test condition.

(4) ±3σ in 1000 sampling or more

(5) ±3σ in 5000 sampling or more

(6) Time to settle output into ±20ppm of specified frequency

### Output clock frequency selection

The AK8130 generates a range of low-jitter and hi-accuracy clock frequencies with three built-in PLLs and provides to up to four assigned outputs. A frequency selection at assigned output pin is configured by pin-setting of S0 (Pin2), S1 (Pin3), and S2 (Pin14).

The selectable frequency is shown in **Table 1..**

**Table 1: Clock output Frequency**

Selection Pin			Clock Output Frequency (MHz)			
S2 (Pin 14)	S1 (Pin 3)	S0 (Pin 2)	CLK1 (Pin 7)	CLK2 (Pin 8)	CLK3 (Pin 10)	CLK4 (Pin 11)
L	L	L	74.250	25.000	OFF	33.333
L	L	H	74.250	25.000	4.9152	OFF
L	H	L	74.250	25.000	OFF	24.576
L	H	H	54.000	OFF	4.9152	24.576
H	L	L	74.1758	25.000	OFF	33.333
H	L	H	74.1758	25.000	4.9152	OFF
H	H	L	74.1758	25.000	OFF	24.576
H	H	H	74.1758	OFF	4.9152	24.576

### Voltage Control Crystal Oscillator (VCXO)

The AK8130 has a voltage control crystal oscillator (VCXO), featuring fine frequency tuning for 27MHz of primary clock frequency by external DC voltage control. This tuning enables output clock frequency to synchronize the external clock system. VIN (Pin 4) accepts DC voltage control from a processor or a system controller, and pulls the primary frequency of crystal to higher or lower. This pulling range is determined by crystal characteristic, on-chip load capacitor, and stray capacitance of PCB. The AK8130 is designed to range  $\pm 110$ ppm of primary frequency in AKEMD's authorized condition, and the typical pulling profile is shown in **Figure 1.** For details about the condition and other specific crystal application case, refer the AK8130 Family application note.

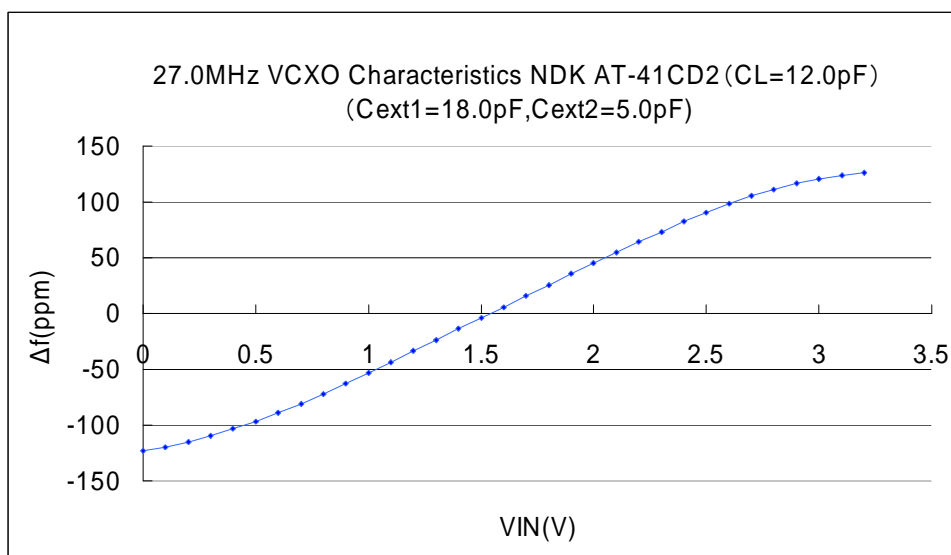

**Figure 1: Typical VCXO Pulling Profile**

## Typical Connection Diagram

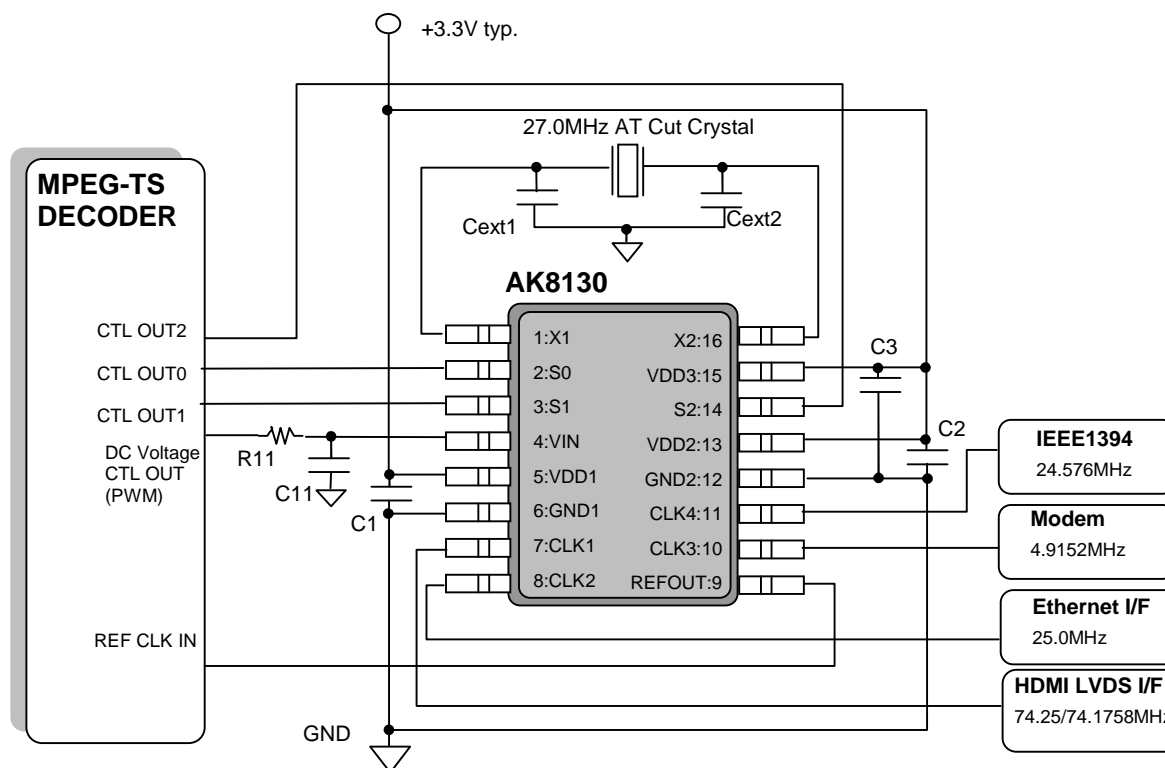

**Figure 2: Typical Connection Diagram**

C1, C2, C3: 0.1 $\mu$ F

Cext1, Cext2: Depends on crystal characteristics. Refer the specification of the crystal.

R11, C11: In case of interface by PWM. For right configuration, refer the specification of the applied processor.

## PCB Layout Consideration

The AK8130 is a high-accuracy and low-jitter multi clock generator. For proper performances specified in this datasheet, careful PCB layout should be taken. The followings are layout guidelines based on the typical connection diagram shown in Figure 2

**Power supply line** – AK8130 has three power supply pins (VDD1-3) which deliver power to internal circuitry segments. A 0.1 $\mu$ F decoupling capacitor should be placed as close to each VDD pin as possible.

**Ground pin connection** – AK8130 has two ground pins (GND1-2). These pin require connecting to plane ground which will eliminate any common impedance with other critical switching signal return. 0.1 $\mu$ F decoupling capacitors placed at VDD1, VDD2, and VDD3 should be grounded at close to the GND1 pin, the GND2 pin, and the GND2, respectively.

**Crystal connection** – Proper oscillation performance and pullable range are susceptible to stray or parasitic capacitors around crystal. The wiring traces to a crystal from X1 (Pin 1) and X2 (Pin 14) have equal lengths with no via and as short in length as possible. These traces should be also located away from any traces with switching signal.

## Package Information

### • Mechanical data

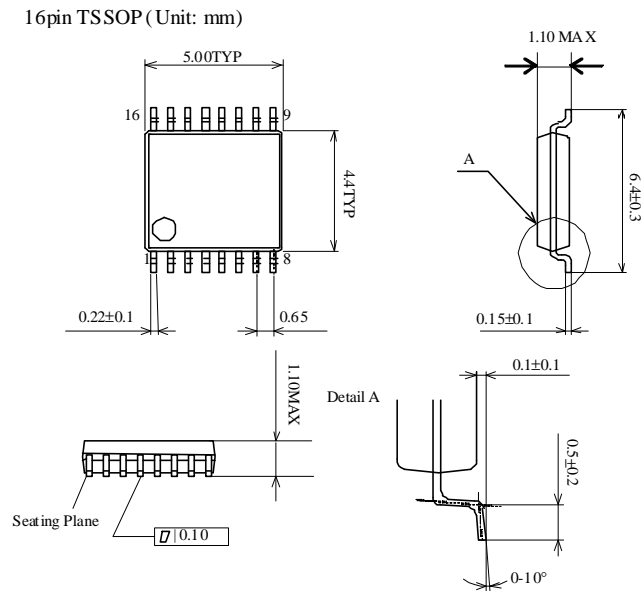

### • Marking

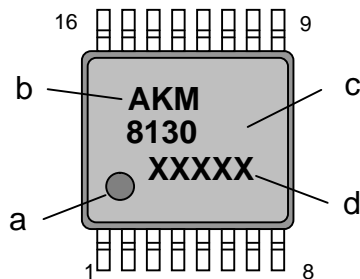

- a: #1 Pin Index
- b: Product Family Logo <sup>(1)</sup>
- c: Part number
- d: Date code (5 digits)

(1) **AKM** is the brand name of AKEMD's IC's.

**AKM** and the logo -  - are the brand of AKEMD's IC's and identify that AKEMD continues to offer the best choice for high performance mixed-signal solution under this brand.

### • RoHS Compliance



All integrated circuits from Asahi Kasei EMD Corporation (AKEMD) assembled in "lead-free" packages\* are fully compliant with RoHS.

(\*) RoHS compliant products from AKEMD are identified with "Pb free" letter indication on product label posted on the anti-shield bag and boxes.

## IMPORTANT NOTICE

- I These products and their specifications are subject to change without notice.  
When you consider any use or application of these products, please make inquiries the sales office of Asahi Kasei EMD Corporation (AKEMD) or authorized distributors as to current status of the products.
- I AKEMD assumes no liability for infringement of any patent, intellectual property, or other rights in the application or use of any information contained herein.
- I Any export of these products, or devices or systems containing them, may require an export license or other official approval under the law and regulations of the country of export pertaining to customs and tariffs, currency exchange, or strategic materials.
- I AKEMD products are neither intended nor authorized for use as critical components<sup>Note1)</sup> in any safety, life support, or other hazard related device or system<sup>Note2)</sup>, and AKEMD assumes no responsibility for such use, except for the use approved with the express written consent by Representative Director of AKEMD. As used here:
  - Note1) A critical component is one whose failure to function or perform may reasonably be expected to result, whether directly or indirectly, in the loss of the safety or effectiveness of the device or system containing it, and which must therefore meet very high standards of performance and reliability.
  - Note2) A hazard related device or system is one designed or intended for life support or maintenance of safety or for applications in medicine, aerospace, nuclear energy, or other fields, in which its failure to function or perform may reasonably be expected to result in loss of life or in significant injury or damage to person or property.
- I It is the responsibility of the buyer or distributor of AKEMD products, who distributes, disposes of, or otherwise places the product with a third party, to notify such third party in advance of the above content and conditions, and the buyer or distributor agrees to assume any and all responsibility and liability for and hold AKEMD harmless from any and all claims arising from the use of said product in the absence of such notification.